

SENSORS FOR MECHANICAL VENTILATION

Reducing a building's energy and cost while improving comfort isn't just about efficient heating and air conditioning. Ventilation is required for both HVAC comfort and good air quality. Without enough ventilation, users will eventually experience comfort issues and even health problems. Mechanical ventilation uses ducts and fans to draw in and distribute fresh air throughout a space, and to exhaust air from specific areas. Mechanical ventilation is beneficial not only for energy efficiency, but to provide more control over the amount of outdoor air added, as well as its source. To accomplish this level of control and efficiency, mechanical ventilation requires data to determine what vents to open or close, and when to extract air based on air quality.

TE CONNECTIVITY ADVANTAGES

- Portfolio Breadth
- Industrial Technology Leadership
- Manufacturing Scale
- Customization Capability

MECHANICAL VENTILATION

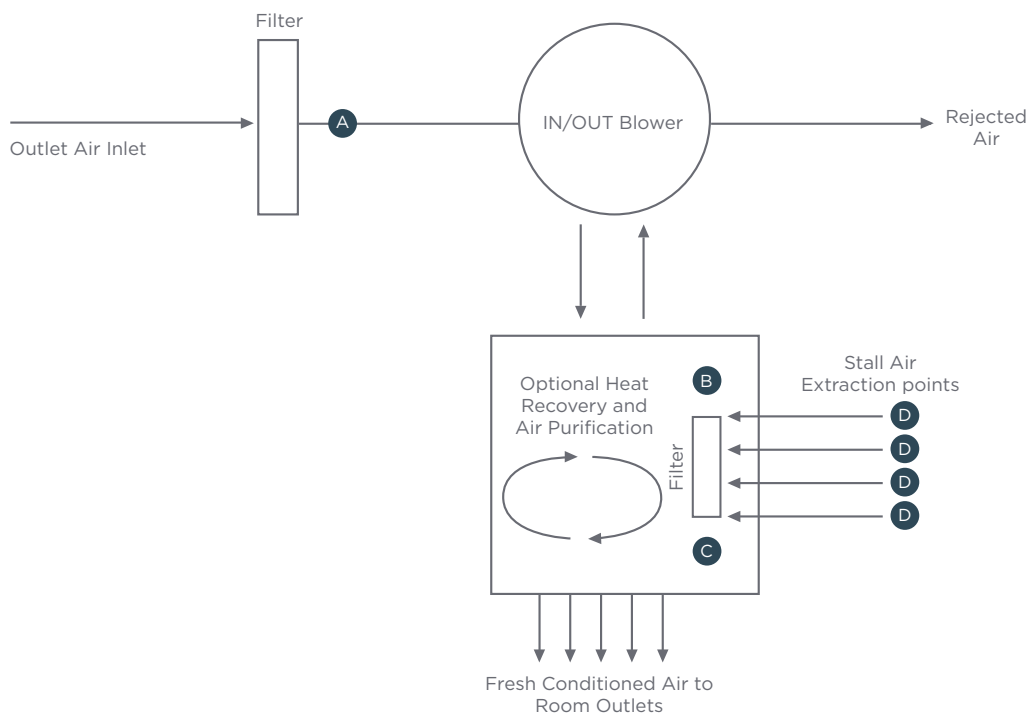

- A Temperature Sensor
- B Humidity Sensor
- C Differential Pressure/ Airflow Sensor/Filter Clogging
- D Temperature Sensor

SENSORS FOR MECHANICAL VENTILATION

Sensor Technology	Application	Key Product Features	Benefits
SM9000 	<ul style="list-style-type: none"> Monitoring very low pressure properties for ventilation VAV and filter monitoring within HVAC systems 	<ul style="list-style-type: none"> Compact low cost, and low power board mount differential microflow pressure sensor that is immune to dust and fumes and are known for long-term stability 	<ul style="list-style-type: none"> Accurate, reliable and repeatable operation over the life of the part The pressure sensor can be mounted directly onto a standard PCB Compensation and calibration eliminates need for additional circuitry or separate calibration
SM7000 	<ul style="list-style-type: none"> Monitoring low air pressure within ventilation systems 	<ul style="list-style-type: none"> Low pressure MEMS transducer technology and CMOS mixed signal processing technology to produce either an analog and or digital output fully conditioned Multi-order pressure and temperature compensated 	<ul style="list-style-type: none"> Accurate, reliable and repeatable operation over the life of the part The pressure sensor can be mounted directly onto a standard PCB Compensation and calibration eliminates need for additional circuitry or separate calibration
HCLA 	<ul style="list-style-type: none"> Measure low pressure properties within HVAC systems 	<ul style="list-style-type: none"> Miniature calibrated and temperature compensated low pressure sensors that perform precision digital signal conditioning and provide analog and digital output at the same time 	<ul style="list-style-type: none"> Space-saving sensor packaging for PCB-mounting and maximum OEM design flexibility Special compensation technique to achieve very high offset stability and virtually no position sensitivity
LMI 	<ul style="list-style-type: none"> Monitors extremely low pressure of VAVs Filter monitoring burner control and other areas of the HVAC system 	<ul style="list-style-type: none"> Extremely low full scale pressure range Accuracy is a percent of reading not a percent of full scale Provides temperature and humidity data also I²C output only 	<ul style="list-style-type: none"> High immunity to dust Extremely high accuracy at very low pressures Longterm stability Small footprint and low profile for space savings
HTU21 	<ul style="list-style-type: none"> Humidity and temperature combination sensors for HVAC applications 	<ul style="list-style-type: none"> Calibrated, linearized signals in digital I²C format Humidity and temperature plug and play transducers Direct interface with a micro-controller with the module for humidity and temperature digital outputs Low power sensor 	<ul style="list-style-type: none"> Relative Humidity and Temperature Digital Output I²C interface Low power consumption for IoT applications Fast response time Full interchangeability with no calibration required in standard conditions
HTU31 	<ul style="list-style-type: none"> Humidity and temperature combination sensors for HVAC applications 	<ul style="list-style-type: none"> High performance humidity and temperature combination sensor Humidity and accurate Available in digital and analog versions 	<ul style="list-style-type: none"> Provides fast response time Precision measurement Low hysteresis and sustained performance Even in the harshest environments
HTU35 	<ul style="list-style-type: none"> Humidity and temperature combination sensors for HVAC applications 	<ul style="list-style-type: none"> High performance humidity and temperature combination sensor Compact and accurate Analog output 	<ul style="list-style-type: none"> Relative Humidity and Temperature analog output Low power consumption Fast response time Full interchangeability with no calibration required in standard conditions
HTG35 	<ul style="list-style-type: none"> Humidity and temperature combination sensors designed for high volume and demanding applications where power consumption is critical 	<ul style="list-style-type: none"> Humidity and temperature plug and play transducers Direct interface with a micro-controller with the module for humidity linear voltage and direct NTC outputs Low power sensor 	<ul style="list-style-type: none"> Suitable for small bulk assembly RoHS compliant Full interchangeability Demonstrated reliability and long term stability Reliability not affected by repeated condensation
820M1 	<ul style="list-style-type: none"> Accelerometer designed for embedded condition monitoring and predictive maintenance applications 	<ul style="list-style-type: none"> Low cost Board mountable accelerometer Designed and qualified for machine health monitoring and has superior resolution, dynamic range and bandwidth to MEMS devices 	<ul style="list-style-type: none"> Proven track record for offering the reliable and long-term stable output required for condition monitoring applications
830M1 	<ul style="list-style-type: none"> Embedded Piezoelectric (PE) accelerometer offering advanced acceleration sensing for machine health monitoring 	<ul style="list-style-type: none"> Embedded Piezoelectric (PE) accelerometer offering advanced acceleration sensing Wide bandwidth Small size Low power, and robust performance are essential 	<ul style="list-style-type: none"> Optimized for critical machine health monitoring the 830M1 offers an outstanding measurement bandwidth (up to 15 kHz) Superior resolution and is designed with highly stable PE sensing technology, to provide long-term, reliable, stable and accurate performance for condition monitoring applications in harsh environments