Find Sense Sensors for Automation by Industry



Sense Proximity Sensors
for **Factory Automation**

Find

What is a Proximity Sensors?

Proximity sensors are electronic devices capable of detecting the proximity of parts, components, machine elements, etc, replacing traditional limit switches.

Detection occurs without physical contact between the actuator and the sensor, which increases the sensor's life as it has no moving parts subject to mechanical wear.

Inductive



Capacitive



Photoelectric



Ultrasonic



What is the types of Proximity Sensors?

Inductive

Inductive sensors are the most cost-effective choice for automation of machinery and equipment. Highly robust for industrial environments, they detect metal parts not only made of iron or steel but also **aluminum, brass, and stainless steel.**

[Video file Sense Inductive Tubular Sensors.mp4](#)

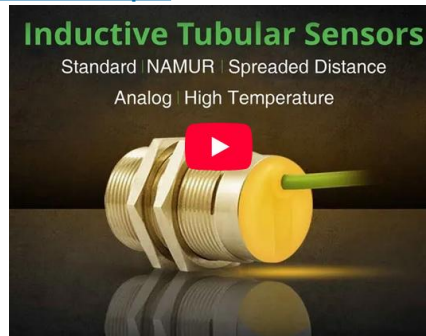

Value proposition

- Robustness product
- 360° high-visibility LED activation indication
- Competitive price
- Short lead time

Capacitive

Capacitive sensors detect any kind of mass, making them ideal for applications that require detecting **non-metallic materials**, such as **plastics, wood, and resins.** They are also commonly used for **liquid and solid level detection** based on changes in dielectric properties.

[Video file Capacitive Sensors.mp4](#)



Value proposition

- Robustness product
- Competitive prices
- Short lead time

What is the types of Proximity Sensors?

Ultrasonic

Microprocessed sensors offer versatile outputs, including:

Digital outputs: Single or dual channels.

Analog outputs: Voltage or current (e.g., 0–10 V, 4–20 mA).

Specialized models: Designed for **double sheet detection**, ensuring accurate identification of overlapping materials.



Value proposition

- Smartphone app to setup the sensor
- Cost Benefit & Short lead time
- Multi-functional configuration app

Photoelectric

Photoelectric sensors offer **extended-range, non-contact detection**, making it possible to sense not only machine components but also the **actual products** produced.





Based on a **light beam** (infrared or visible) using through-beam, retro-reflective, or diffuse modes.



Value proposition

- Cost Benefit
- Short lead time
- Competitive price

Proximity Sensors – Applications and Market

	Type	What does it detect?	Where is it used?
	Inductive	Detection of metallic objects	Industrial automation, machine tools, automotive assembly, and robotics
	Capacitive	Detection of non-metallic materials such as liquids, plastics, wood, and paper	Used in packaging, food and beverage, and process control industries
	Photoelectric	Detect objects regardless of material	Used in production lines for counting, positioning, or checking the presence of objects. Also popular in security systems.
	Magnetic	Detection of magnetic fields	mainly used in industrial automation, door and window control, and in security equipment
	Ultrasonic	Distance measurement and object detection	Used in machines for liquid level control, object detection, and flow measurement

Inductive Sensors Lineup



**STANDARD
INDUCTIVE**



**NAMUR
INDUCTIVE**



**ENHANCED
INDUCTIVE**



**NON-TUBULAR
INDUCTIVE**



**METALLIC FRONT
INDUCTIVE**



**ANALOGIC
INDUCTIVE**



**ESPECIAL
INDUCTIVE**



**HIGH TEMPERATURE
INDUCTIVE**



**BRACKET FOR
TUBULAR SENSORS**



**EXAMPLES OF
APPLICATIONS**

Capacitive Sensors Lineup

Capacitive sensors detect any type of mass, so they are used where there is a need to detect non-metallic materials such as plastics, wood and resins. They are also used to detect the level of liquids and solids.



**TUBULAR
CAPACITIVES**



**NON-TUBULAR
CAPACITIVE**

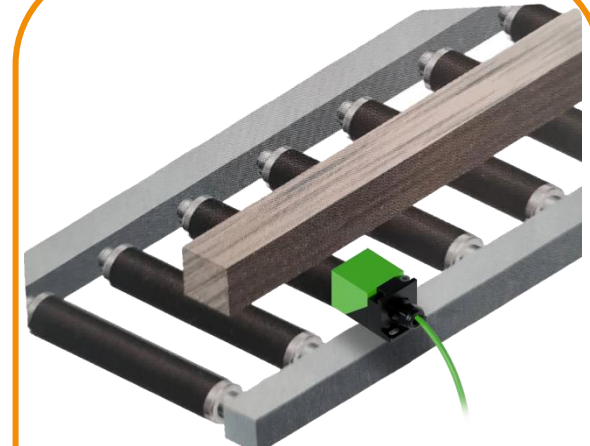

**APPLICATION
EXAMPLES**

Photoelectric Sensors Lineup

By increasing the detection range without physical contact, photoelectric sensors are able to detect not only parts and pieces of automatic machines, but the manufactured products themselves on the production line.



**TUBULAR
PHOTOELECTRIC**

Size: M12, M18 , M30
Distance:



**NON-TUBULAR
PHOTOELECTRIC**

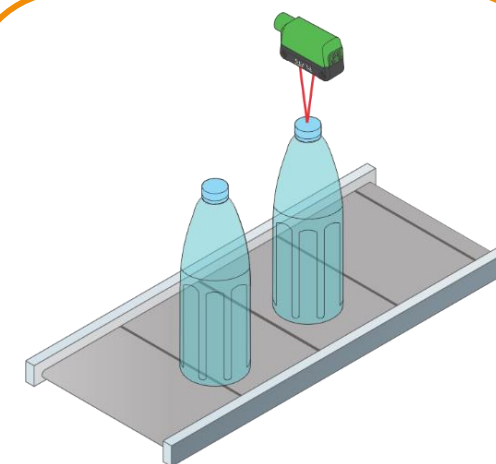

**APPLICATION
EXAMPLES**

Magnetic Sensors Lineup

Magnetic proximity sensors are designed to detect the magnetic field generated by a magnet, which can act as a magnetic actuator. They are used for monitoring linear valves or pneumatic cylinders. Sense offers three types of magnetic actuators. The tubular models are available with either plastic or metallic tubing.



**TUBULAR
MAGNETS**



**MAGNETIC
PNEUMATIC CYLINDERS**

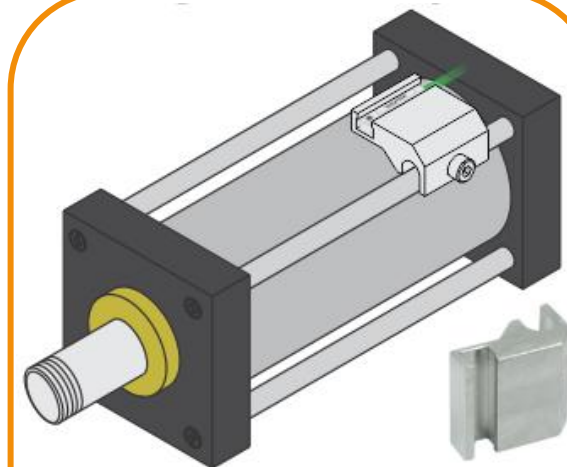

**APPLICATION
EXAMPLES**

Ultrasonic Sensors Lineup

Ultrasonic sensors operate by detecting sound wave reflections, enabling them to identify any material type irrespective of color, surface reflectivity, or opacity. This makes them ideal for liquid detection applications, including transparent fluids (e.g., water, solvents) and turbid media (e.g., wastewater, oils), as their performance is unaffected by visual properties.



**ULTRASONIC
SENSOR ECO**



**US4.SMART
ULTRASONIC**



**EXAMPLE
APPLICATIONS**

Ex Conveyor Solutions Lineup

Speed monitors, proximity and temperature sensors for conveyors with combustible dust in explosive atmospheres that are found in various types of industries, such as: furniture, textiles, warehouses and grain or bran storage silos and port areas, etc.



SPEED MONITOR



MOUNTING BRACKET



BEARING TEMPERATURE SENSOR



BELT MISALIGNMENT SENSOR



M30 CAPACITIVE SENSOR

Electronic Controls Lineup

The range of electronic controls is applicable to proximity sensors. It uses the most modern microcontroller techniques and switched power supply circuits.

The products include:

- Power supplies with logic controls and timers
- Power supplies with single or double relay
- Level controller
- Speed monitor
- Rotation direction control
- Transmitters and speed indicators



**KD
LINE**



**KMV
LINE**