

# MOUNTING CONDITIONS

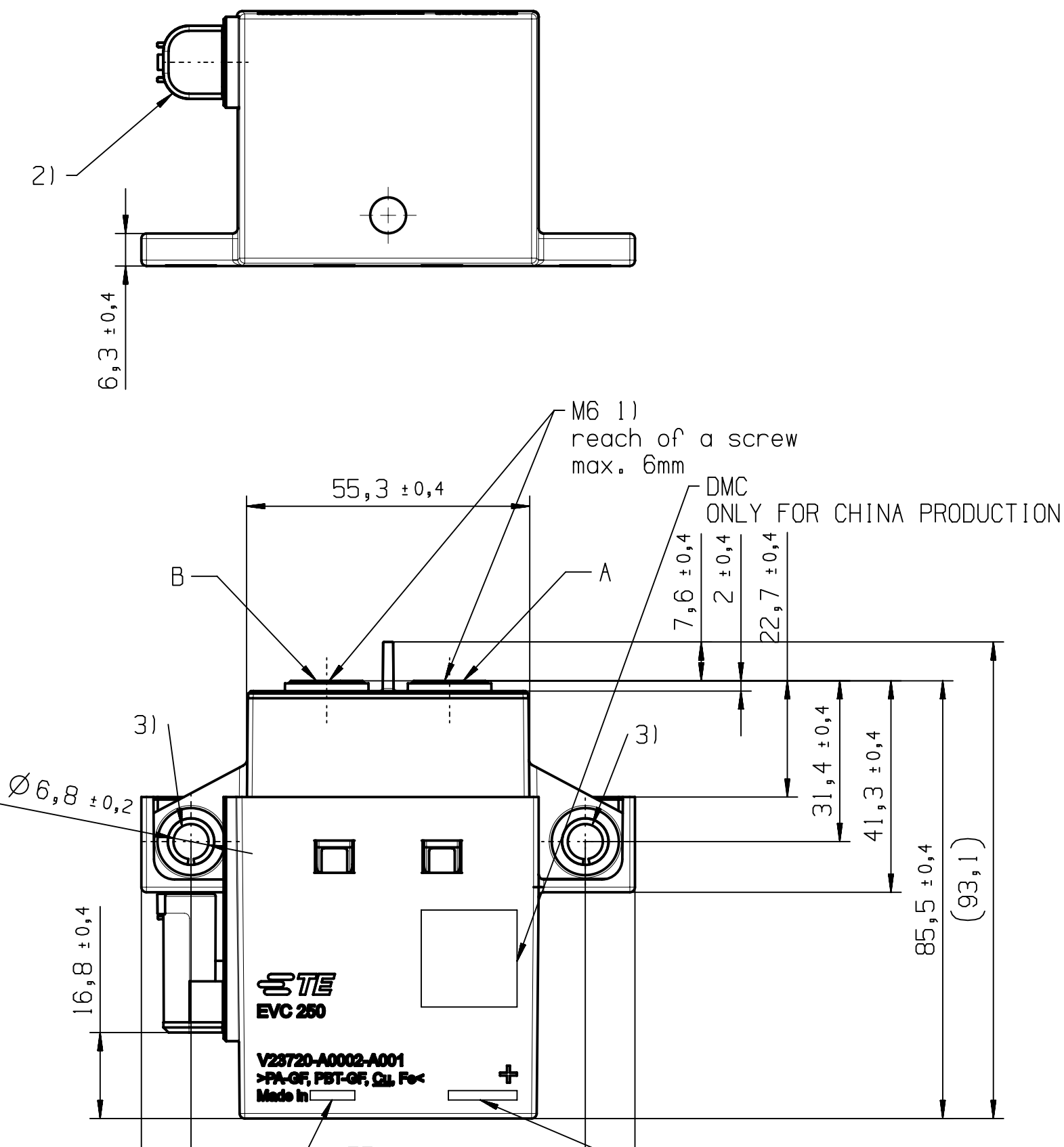

DATE CODE  
FONT ARIAL  
HEIGHT = 2,8  
\*\*YYWWDSL  
\*\* = MANUFACTURE LOCATION  
++ EVORA  
+ = CHINA  
YY = YEAR  
WW = WEEK  
D = WORKING DAY  
S = SHIFT  
L = MANUFACTURE LINE  
A = PORTUGAL  
B = CHINA

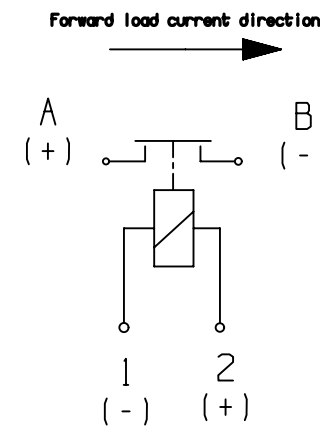
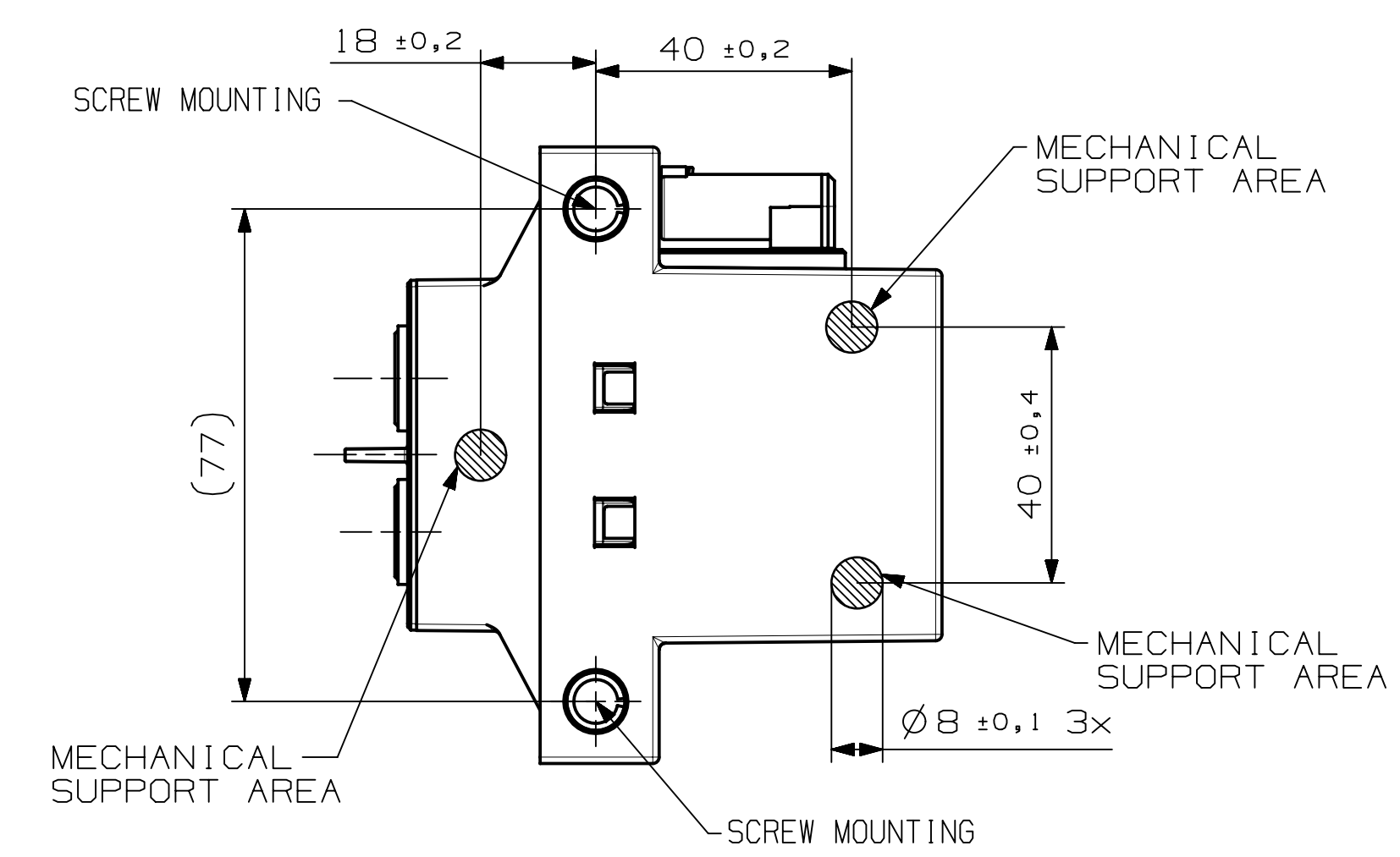
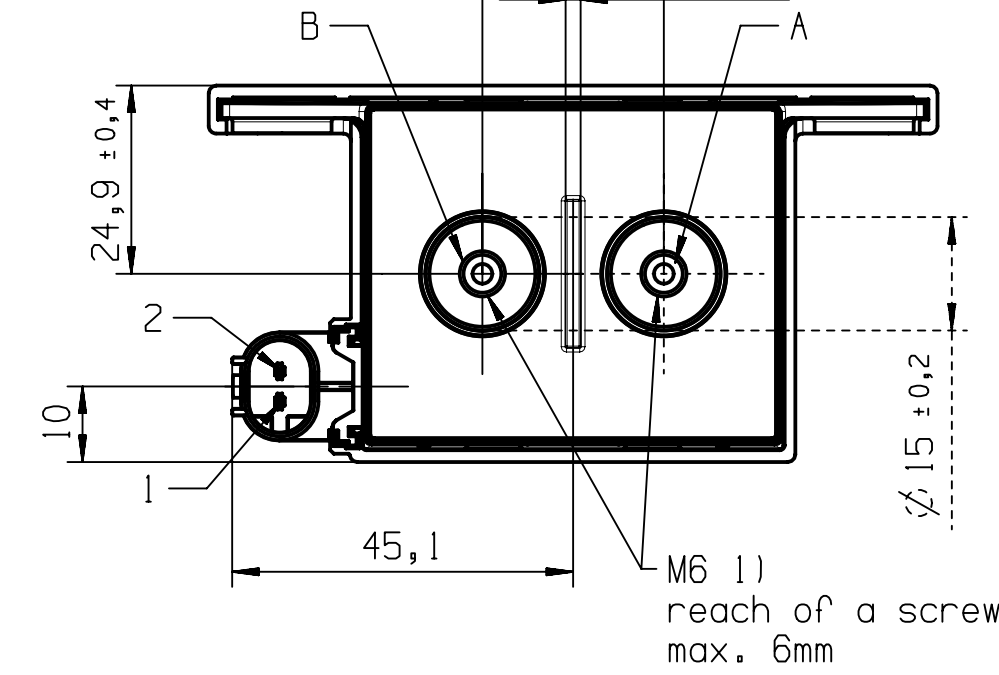

SCALE 2:1

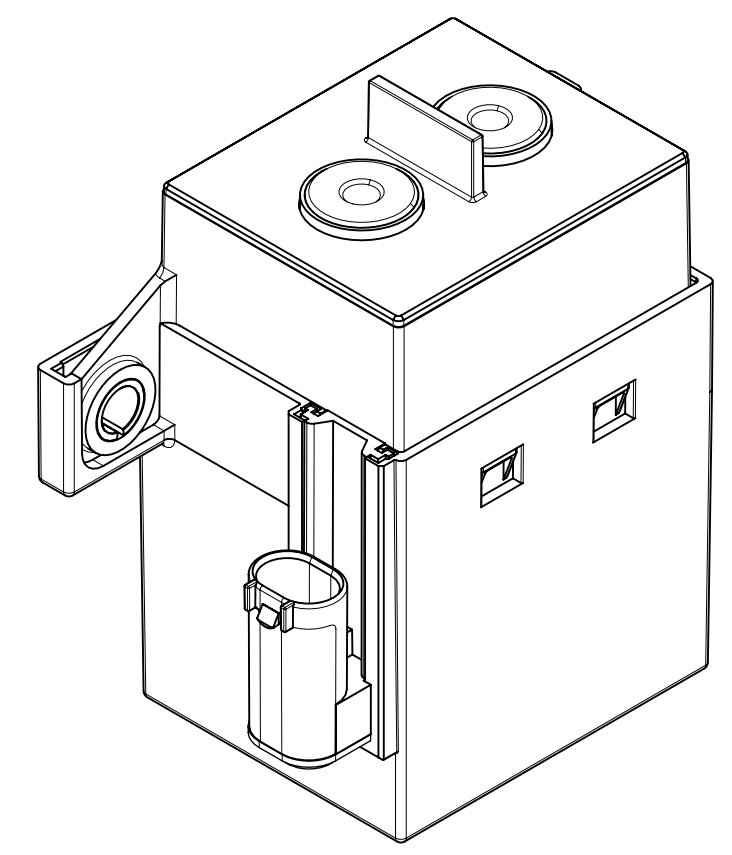
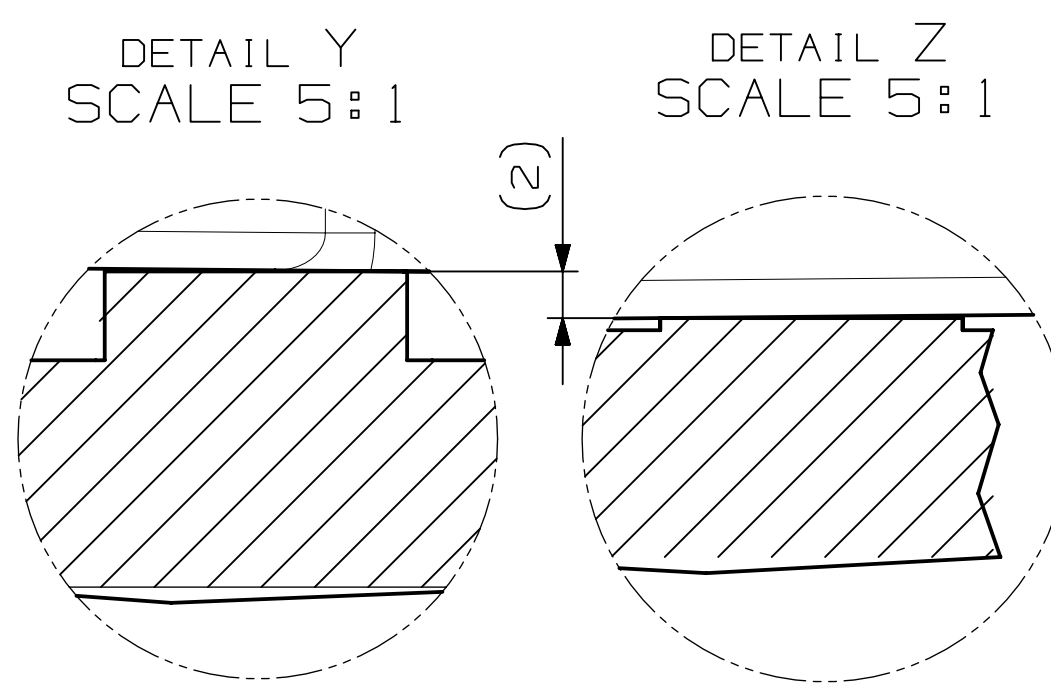
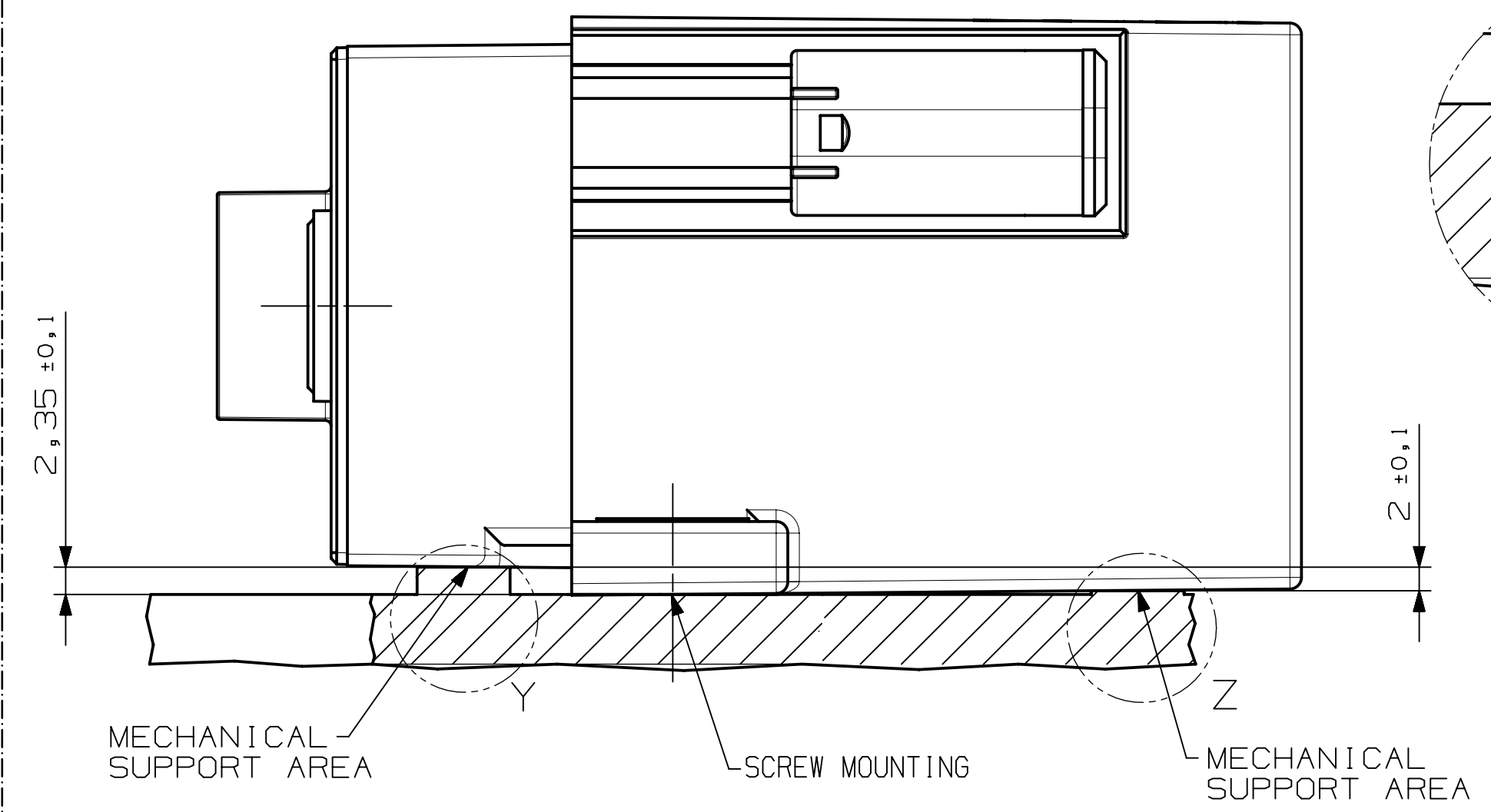

- Notice :
- 1) PERMITTED TORQUE 6 Nm MAX. WHEN MIN. 4 TURNS
  - 2) Socket Housing  
TE Interface 2 Pos. MQS Code A ,  
appropriate for Socket Housing 2 Pos. MQS,  
TE PART NO. I-967644-1  
PRESCRIBED WIRE CROSS SECTION : 0,35mm<sup>2</sup> MIN
  - 3) HEXAGON SOCKET BOTTOM HEAD SCREW EN ISO 7380 M6 WITH  
WASHER ISO 7090/ 7089

ALIAS		TE P/N		REV																																																																
V23720-A0002-A001		4-1904065-7		K																																																																
<small>THE REPRODUCTION, TRANSMISSION OR USE OF THIS DOCUMENT OR IT'S CONTENTS IS NOT PERMITTED WITHOUT EXPRESSED WRITTEN AUTHORITY. OFFENDERS WILL BE LIABLE FOR ALL DAMAGES. ALL RIGHTS, INCLUDING RIGHTS CREATED BY REGISTERED PATENT(S) GRANTED FOR A UTILITY MODEL OR DESIGN, ARE RESERVED.</small>																																																																				
APPLICABLE SPEC. :			FINISH																																																																	
DIMENSIONS APPLY			PLATING																																																																	
SCALE 1:1			WEIGHT 602g																																																																	
TOLERANCE UNLESS SPECIFIED OTHERWISE ISO 8015 ISO 2768-cL			DIMENSIONS IN MM																																																																	
<table border="1"> <thead> <tr> <th>REV.</th> <th>CHANGE ORDER</th> <th>DATE</th> <th>APP.</th> <th>DATE</th> <th>NAME</th> <th>LOCATION</th> <th>BLN.T</th> </tr> </thead> <tbody> <tr> <td>K</td> <td>ECO-22-165143</td> <td>2022-07-19</td> <td>LAM</td> <td>2013-12-12</td> <td>KOCH</td> <td></td> <td></td> </tr> <tr> <td>J1</td> <td>ECO-20-009836</td> <td>2020-07-14</td> <td>LAM</td> <td>APP.</td> <td></td> <td></td> <td></td> </tr> <tr> <td>J</td> <td>ECO-19-018184</td> <td>2020-02-14</td> <td>KOC</td> <td>REV.</td> <td></td> <td></td> <td></td> </tr> <tr> <td>H</td> <td>ECO-19-001520</td> <td>2019-02-01</td> <td>KOC</td> <td>LOCATION</td> <td></td> <td></td> <td></td> </tr> <tr> <td>G</td> <td>ECO-18-014483</td> <td>2018-08-12</td> <td>KOC</td> <td></td> <td></td> <td></td> <td></td> </tr> <tr> <td>E</td> <td>ECO-17-012715</td> <td>2017-08-30</td> <td>KOC</td> <td></td> <td></td> <td></td> <td></td> </tr> <tr> <td>D1</td> <td>ECO-17-011458</td> <td>2017-08-07</td> <td>KOC</td> <td></td> <td></td> <td></td> <td></td> </tr> </tbody> </table>					REV.	CHANGE ORDER	DATE	APP.	DATE	NAME	LOCATION	BLN.T	K	ECO-22-165143	2022-07-19	LAM	2013-12-12	KOCH			J1	ECO-20-009836	2020-07-14	LAM	APP.				J	ECO-19-018184	2020-02-14	KOC	REV.				H	ECO-19-001520	2019-02-01	KOC	LOCATION				G	ECO-18-014483	2018-08-12	KOC					E	ECO-17-012715	2017-08-30	KOC					D1	ECO-17-011458	2017-08-07	KOC				
REV.	CHANGE ORDER	DATE	APP.	DATE	NAME	LOCATION	BLN.T																																																													
K	ECO-22-165143	2022-07-19	LAM	2013-12-12	KOCH																																																															
J1	ECO-20-009836	2020-07-14	LAM	APP.																																																																
J	ECO-19-018184	2020-02-14	KOC	REV.																																																																
H	ECO-19-001520	2019-02-01	KOC	LOCATION																																																																
G	ECO-18-014483	2018-08-12	KOC																																																																	
E	ECO-17-012715	2017-08-30	KOC																																																																	
D1	ECO-17-011458	2017-08-07	KOC																																																																	
PROPRIETARY <small>THE REPRODUCTION, TRANSMISSION OR USE OF THIS DOCUMENT OR IT'S CONTENTS IS NOT PERMITTED WITHOUT EXPRESSED WRITTEN AUTHORITY. OFFENDERS WILL BE LIABLE FOR ALL DAMAGES. ALL RIGHTS, INCLUDING RIGHTS CREATED BY REGISTERED PATENT(S) GRANTED FOR A UTILITY MODEL OR DESIGN, ARE RESERVED.</small>			CHANGES TO THIS DRAWING MUST BE DONE ONLY IN CAD																																																																	
PAPER SIZE A1			PART NAME <b>EVC 250, HV-RELAY WITH CONNECTOR</b>																																																																	
DWG NO. V23720-A0002-A001			SHT. 1 OF 1																																																																	