

a) Part as supplied.

KTKK 0603-0611

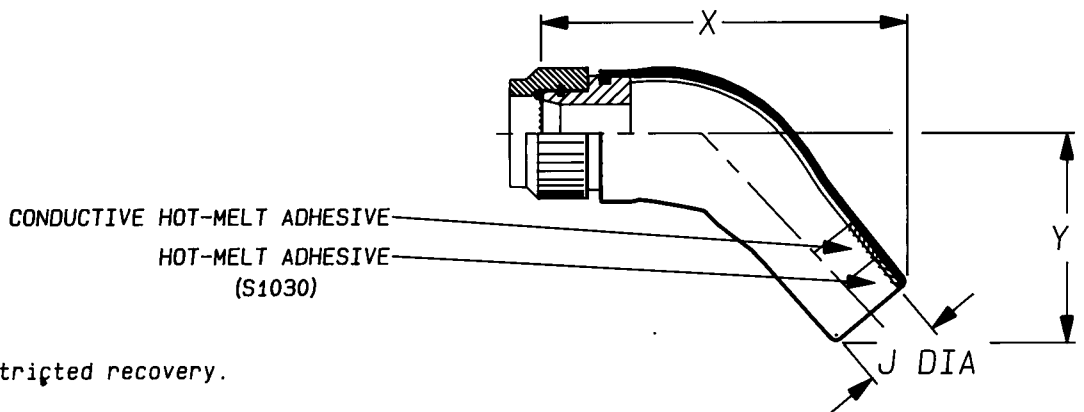

b) Part after unrestricted recovery.

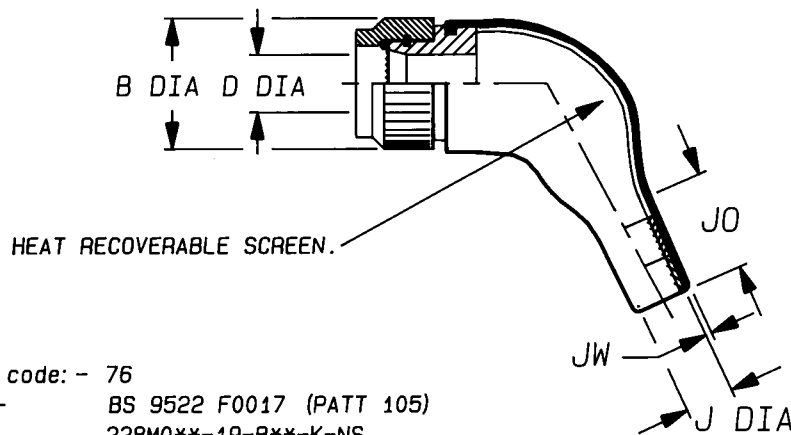

Raychem connector code: - 76
 Connector Series: - BS 9522 F0017 (PATT 105)
 Adaptor Series: - 228M0**-19-B**-K-NS
 Moulded Part Material: - -100S

Kits to include cleaning tissue, 1 piece 100 grit emery cloth & packing piece.
 Kit to be used in conjunction with installation guide for 90 & 45 deg. assemblies.

Dimensions (in millimetres.)

Part No.	SHELL SIZE	B	D	J		JO	JW	X	Y
		DIA MAX	DIA MIN	MIN a	MAX b	REF b	±30% b	±20% a	±20% a
KTKK 0603	8	17.1	6.3	7	5.0	15	1.0	63	23
KTKK 0604	10	20.1	9.4	9	6.0	17	1.0	70	29
KTKK 0605	12	23.6	13.4	11	7.2	18	1.0	76	29
KTKK 0606	14	26.6	14.2	11	7.2	18	1.0	76	29
KTKK 0607	16	30.1	18.9	17	8.5	20	1.0	86	36
KTKK 0608	18	33.1	18.9	17	8.5	20	1.0	86	36
KTKK 0609	20	36.6	23.7	21	10.0	28	1.5	103	45
KTKK 0610	22	39.6	23.7	21	10.0	28	1.5	103	45
KTKK 0611	24	43.1	30.9	29	15.8	31	1.5	124	58

Copyright (!)

Urheberrechte

The copyright in this drawing is the property of Raychem Ltd. The drawing is issued on condition that it is not copied, reproduced or disclosed to a third party, either in whole or in part without the prior written consent of Raychem Ltd.

Drawn A.LILLEY. Checked *KL* Issue 2 Date October 1993 Conforms to ISO Recommendations

Approval

Design *AA Sutter* MKTG. *de*

G.C. *m*

3rd Angle Projection
Not to Scale

