

P	LTR	DESCRIPTION	DATE	DWN	APVD
	B	INITIAL RELEASE	20OCT2020	GK	MN

LABEL AND LINER DESIGN

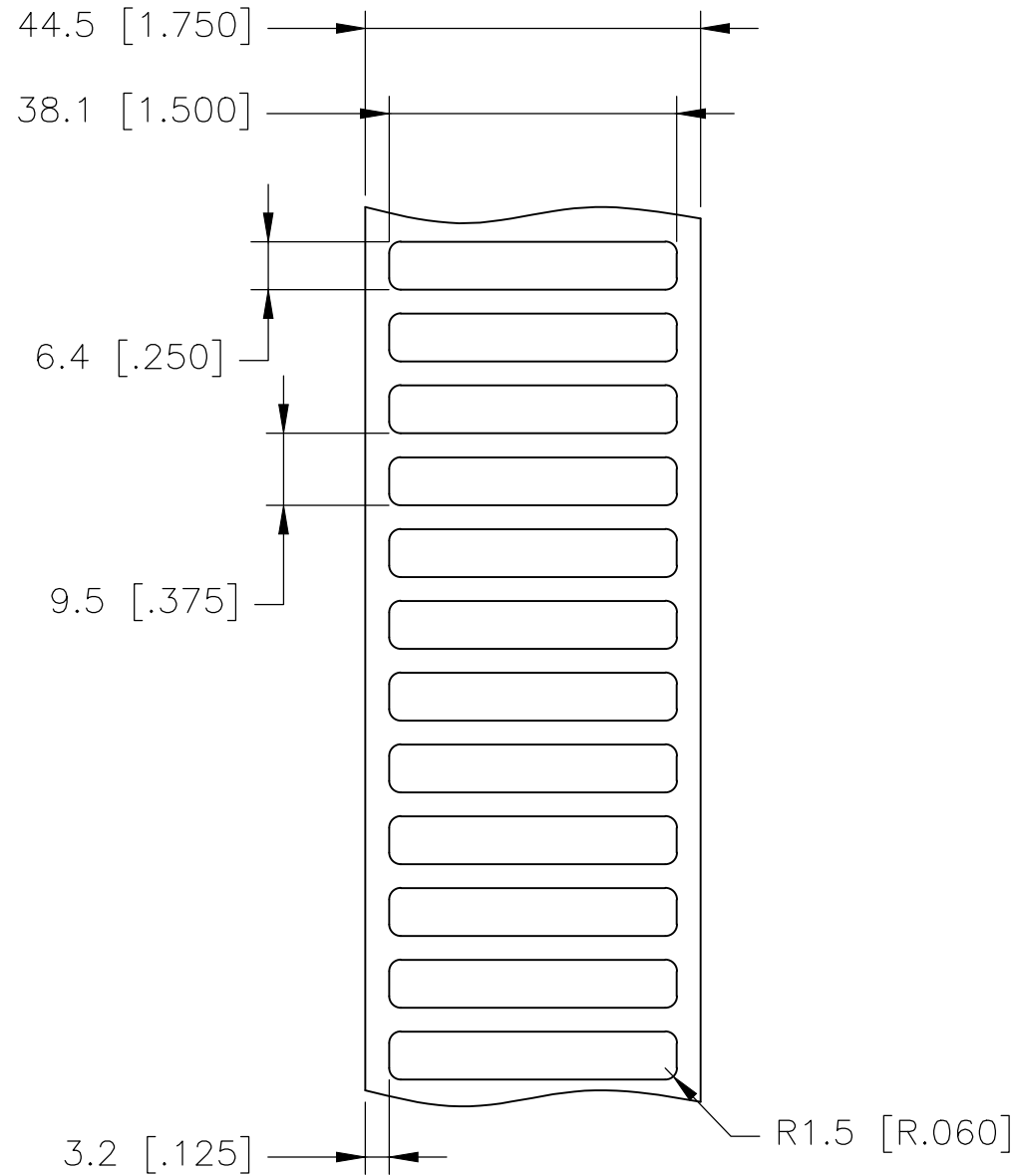

PRESENTATION

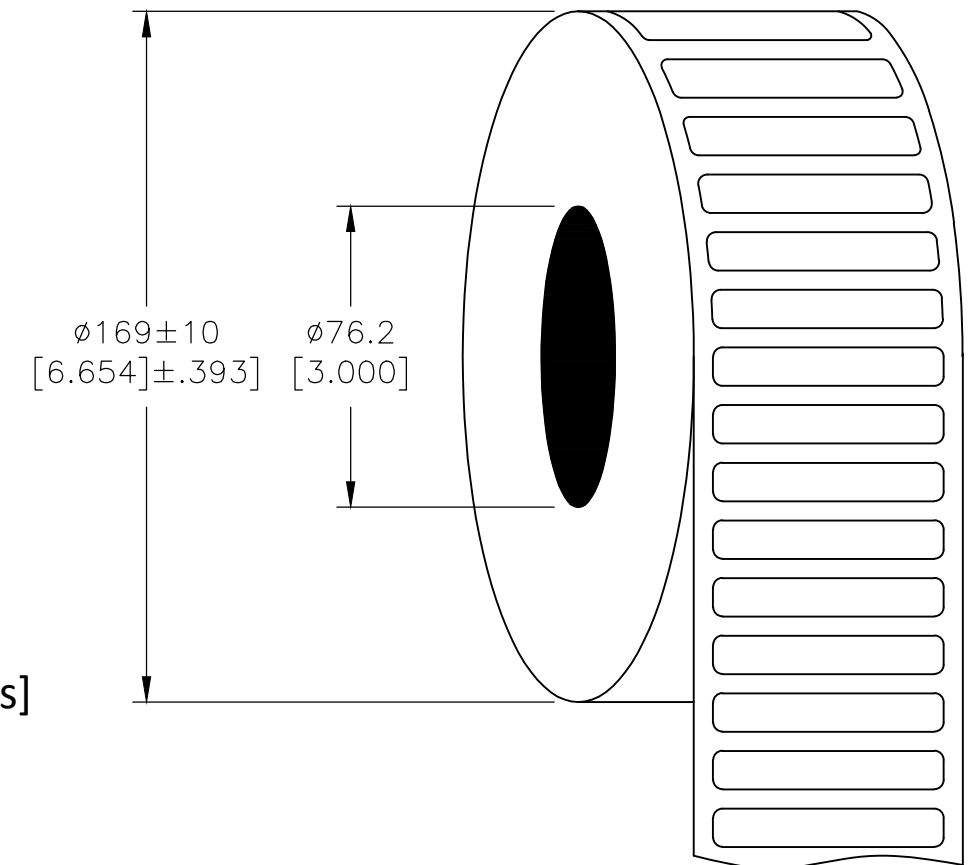

All dimensions in mm [Inches]

TE PN: D88272-000

**OUTSIDE WOUND
 LABEL ACROSS: 1
 PER ROLL QTY: 10000**

MATERIAL	HIGH TACK WHITE POLYESTER
ADHESIVE TYPE	PERMANENT ACRYLIC
LINER	GLASSINE PAPER

TOLERANCES mm [INCH]	
LABEL HEIGHT:	±0.3 [.012]
LABEL WIDTH:	±0.3 [.012]
WEB WIDTH:	±0.8 [.031]
VERTICAL REPEAT:	±0.8 [.031]*
HORIZONTAL REPEAT:	±0.8 [.031]*
PRINT POSITIONING:	±0.8 [.031]*
LEFT MARGIN:	±0.4 [.016]
QUANTITY:	-0 % +2 %
*NON ACCUMULATING	

THIS DRAWING IS A CONTROLLED DOCUMENT.	
DIMENSIONS: mm [INCHES]	TOLERANCES UNLESS OTHERWISE SPECIFIED:
	0 PLC ± -
	1 PLC ± -
	2 PLC ± -
	3 PLC ± -
	4 PLC ± -
ANGLES ± -	FINISH -
MATERIAL SEE TABLE	

DWN	20OCT2020
CHK	GOPALAKRISHNA HV
APVD	20OCT2020
MIKE NUTTALL	
MIKE NUTTALL	
PRODUCT SPEC	TTDS-076
APPLICATION SPEC	-
WEIGHT	0.029g

TE Connectivity		NAME		RESTRICTED TO
		HW - HIGH TACK WHITE POLYESTER LABELS		
SIZE	CAGE CODE	DRAWING NO	-	
A3	C2290	C=HW-381064-10-9	-	
CUSTOMER DRAWING		SCALE	SHEET	REV
		NTS	1 OF 1	B