

P	LTR	DESCRIPTION	DATE	DWN	APVD
	G	INITIAL RELEASE	20OCT2020	GK	MN

LABEL AND LINER DESIGN

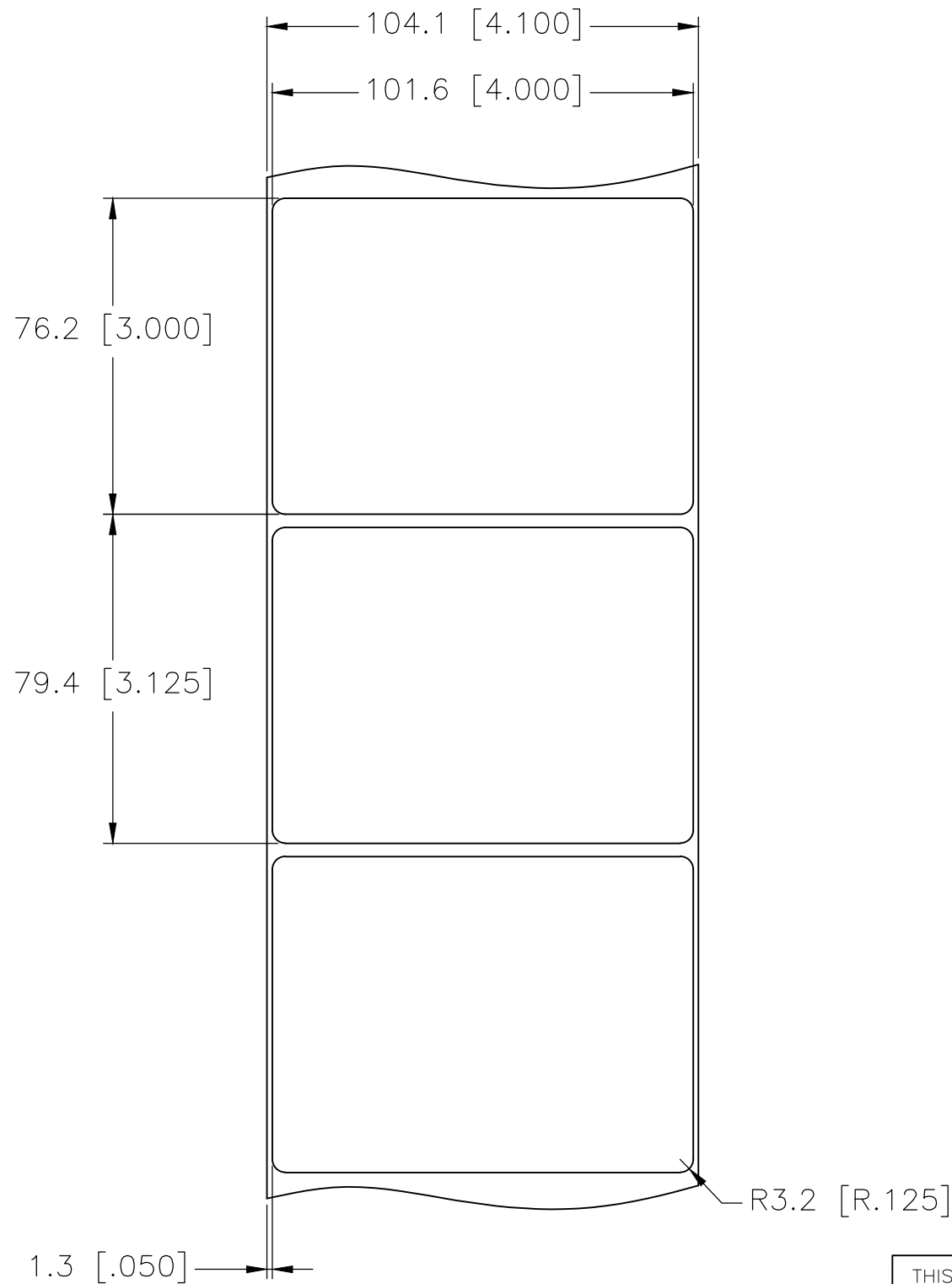

PRESENTATION

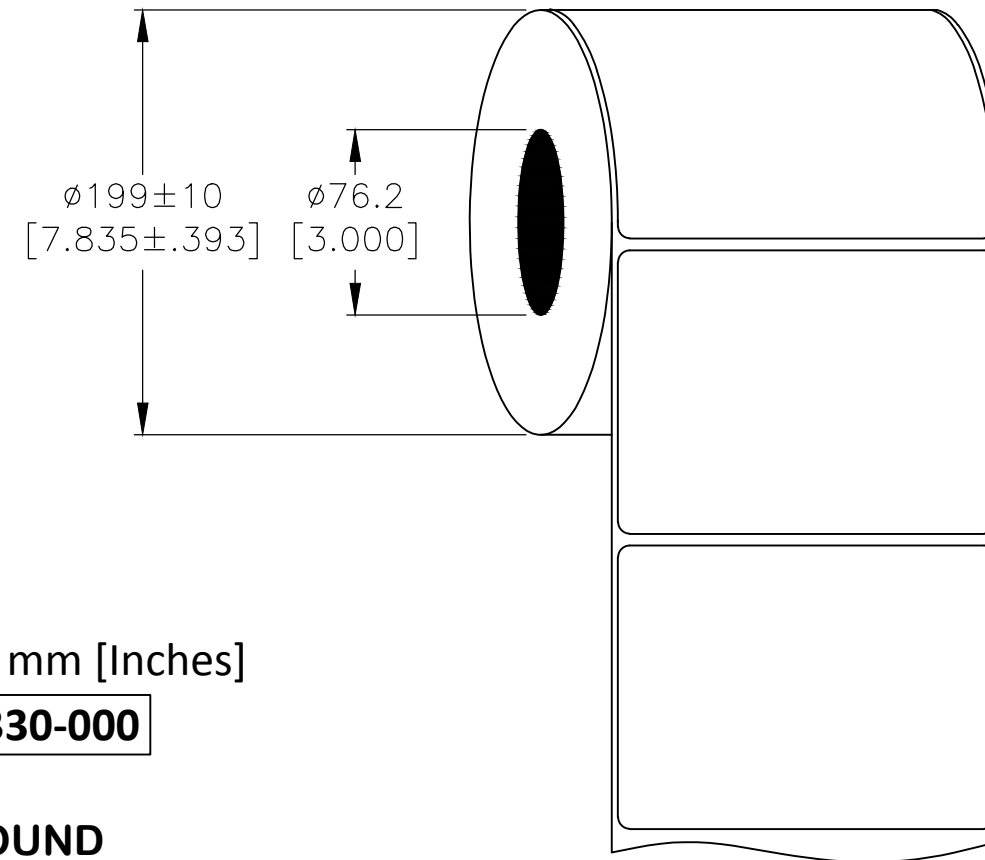

All dimensions in mm [Inches]

TE PN: D67330-000

**OUTSIDE WOUND
LABEL ACROSS: 1
PER ROLL QTY: 1800**

MATERIAL	HIGH TACK WHITE POLYESTER
ADHESIVE TYPE	PERMANENT ACRYLIC
LINER	GLASSINE PAPER

TOLERANCES mm [INCH]	
LABEL HEIGHT:	± 0.3 [.012]
LABEL WIDTH:	± 0.3 [.012]
WEB WIDTH:	± 0.8 [.031]
VERTICAL REPEAT:	± 0.8 [.031]*
HORIZONTAL REPEAT:	± 0.8 [.031]*
PRINT POSITIONING:	± 0.8 [.031]*
LEFT MARGIN:	± 0.4 [.016]
QUANTITY:	-0 % +2 %
*NON ACCUMULATING	

DIMENSIONS:		TOLERANCES UNLESS OTHERWISE SPECIFIED:	
mm [INCHES]			
	0 PLC	\pm	-
	1 PLC	\pm	-
	2 PLC	\pm	-
	3 PLC	\pm	-
	4 PLC	\pm	-
ANGLES		\pm	-
FINISH			
MATERIAL		SEE TABLE	

DWN	20OCT2020	GOPALAKRISHNA HV
CHK	20OCT2020	MIKE NUTTALL
APVD	20OCT2020	MIKE NUTTALL
PRODUCT SPEC	TTDS-076	
APPLICATION SPEC	-	
WEIGHT	0.908g	

		TE Connectivity	
		NAME	
HW - HIGH TACK WHITE POLYESTER LABELS		-	
SIZE	CAGE CODE	DRAWING NO	RESTRICTED TO
A3	C2290	G-HW-101762-1.8-9	-
CUSTOMER DRAWING		SCALE	SHEET
		NTS	1 OF 1
		REV	G