

P	LTR	DESCRIPTION	DATE	DWN	APVD
NC		NEW RELEASE PER E.O. P19981	09SEP2008	-	DN
A		REVISED PER E.O. P20028	17NOV2008	-	RDR
AI		REVISED PER PCN E-20-013840	18SEP2020	MK	IG
B		REVISED PER PCN-24-219306	29AUG2024	CO	CB

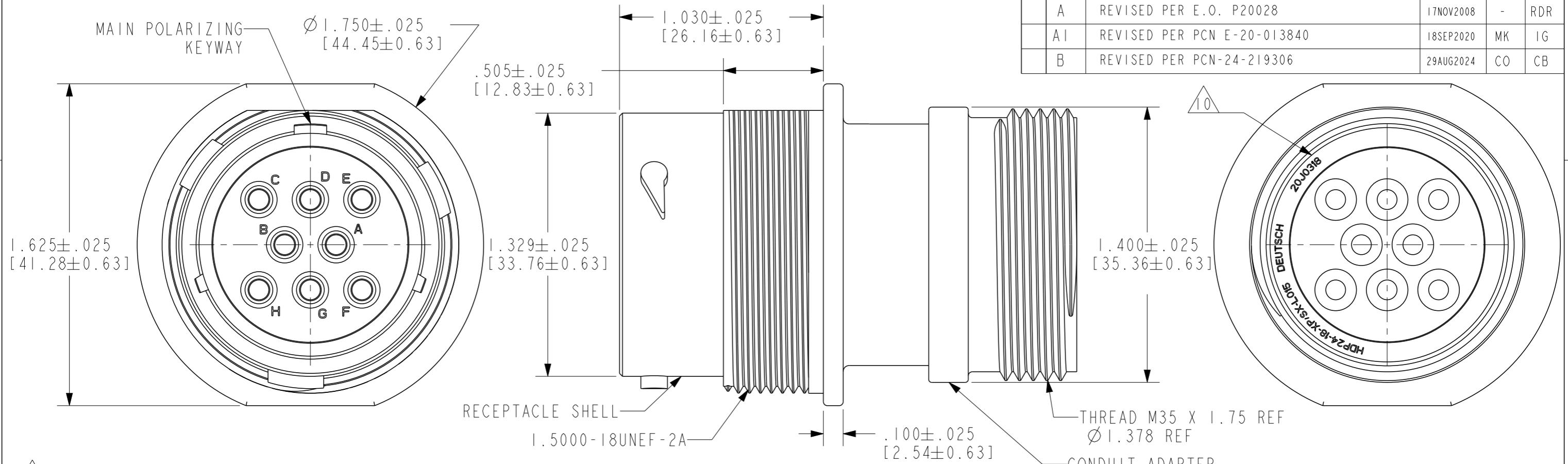

10 DATE CODE: IDENTIFIES THE YEAR, MONTH, DAY AND HOUR OF ASSEMBLY.
 YEAR: FIRST AND SECOND DIGITS. (14=2014)
 MONTH: THIRD DIGIT, EXCLUDING I.A=JAN., B=FEB., C=MARCH... (K=OCT.)
 DAY: FOURTH AND FIFTH DIGIT (14=14th DAY)
 HOUR: SIXTH AND SEVENTH DIGIT (11=11AM)

- 18-8 ARRANGEMENT SHOWN FOR REFERENCE ONLY.
- THIS RECEPTACLE TO BE USED WITH 2414-002-1886 LOCK WASHER AND 2411-002-1805 PANEL NUT.
- FOR PERFORMANCE AND APPLICATION CHARACTERISTICS SEE ENVELOPE DRAWING 0425-021-0000.
- PART NUMBER INFO: **=ARRANGEMENT; *=SEAL TYPE
- THIS RECEPTACLE MATES WITH HDP26-18-**P/S*-**** (****=ALL MODIFICATIONS)
- FOR CONTACTS AND WIRE PERFORMANCE AND APPLICATION CHARACTERISTICS SEE ENVELOPE DWG. 0425-015-0000.
- RECOMMENDED PANEL THICKNESS: .062(1.57) TO .1875(4.76) MAX.
- SILICONE GROMMET COLOR REFLECTS WIRE SEAL DIAMETER. (GREEN='N' SEAL; GREY='T' SEAL; BLUE='E' SEAL)
- FOR CONTACT ARRANGEMENTS, SEE ENVELOPE DRAWING 0425-014-2400.

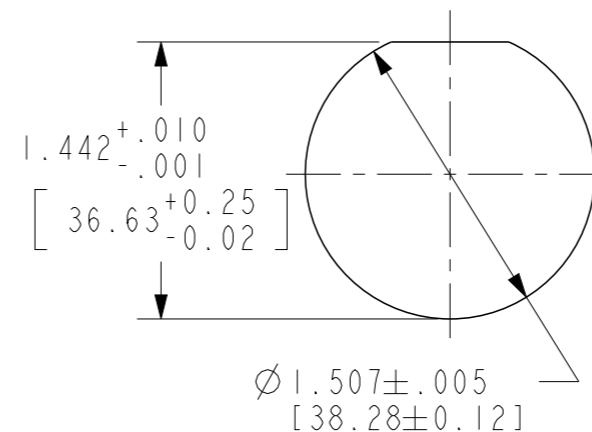

RECOMMENDED PANEL MOUNTING HOLE

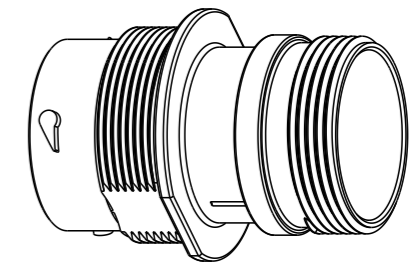

3D VIEW

THIS DRAWING IS A CONTROLLED DOCUMENT.		DWN	12 JUL 2007			TE Connectivity		
DIMENSIONS: INCH [MM]		CHK	I. GRANTCHAROVA 14 NOV 2008			NAME PLASTIC RECEPTACLE CONNECTOR BAYONET COUPLING HDP SERIES SIZE 18 -L015 MOD	RESTRICTED TO	
TOLERANCES UNLESS OTHERWISE SPECIFIED:		APVD	B. BYFORD 06 NOV 2008				SIZE	CAGE CODE
0 PLC ±- 1 PLC ± 2 PLC ± 3 PLC ±.025 4 PLC ±- ANGLES ±-		PRODUCT SPEC	108-151015			A3	00779	©=HDP24-18-XXPSX-L015
MATERIAL		APPLICATION SPEC	114-151015		WEIGHT	40.4 g		
FINISH		CUSTOMER DRAWING			SCALE	1.000		
					SHEET	OF		
					REV	B		