

---

# ELE-3COP-259

## Title – Cable preparation when using 202C6XX Uniboot Moulded Parts with Tinel™ Adaptors.

---

Before starting work please read this document carefully and note the guidance given.

### 1 Purpose and Scope

This COP describes the procedure to be used when preparing screened and jacketed component wires when used with Straight, 90° and 45° Tinel™ Adaptors and 202C6XX Uniboot moulded parts. The instructions in this document take preference over IPC/WHMA requirements, as do the drawing and any customer documentation.

### 2 Performance Objective

This code of practice is produced to support operators already trained in the installation of heat shrinkable and harnessing products. It identifies the procedure to be used for maintaining the screening of individual cable components to as close to the rear of the connector as practical, whilst allowing maximum access to the completed connector termination. Uniboosts have convolutions that compress and allow access to the rear of the connector for 'cold' repair. Their length allows individual screen terminations to be staggered to minimise bundle diameter increase.

### 3 Materials and Equipment:

Refer to documents ELE-3COP-251 and ELE-3COP-254

### 4 Health and Safety

Adhere to local Codes and Regulations relating to Safe Working practices. For the U.K. adhere to requirements of the Health and Safety at Work Act 1974 and subsequent amendments. A knife should never be used for wire stripping as this can easily cause personal injury and conductor damage.

### 5 Procedure

The following sections detail the recommended cable preparation when using 202CXX Uniboot Moulded parts and TE straight braided adaptor terminations.

Strip outer cable jacket to the dimension shown, adding 15 mm to this dimension where wire loops are required.

Fold outer shield back over cable jacket.

Centre strip screened components to the dimension shown adding 15 mm to this dimension where wire loops are required.

Install the appropriate Solder Sleeve as specified on the drawing, wire from shield termination may face towards or away from the connector.

## ELE-3COP-259

### Title – Cable preparation when using 202C6XX Uniboot Moulded Parts with Tinel™ Adaptors.

Cut back component shield and jacket to the dimension shown, adding 15 mm to this dimension where wire loops are required.

Install the appropriate Insulation Sleeve as specified on the drawing. When the component screen is not terminated, strip component outer jacket to the dimensions shown and insulate shield using appropriate Insulation Sleeve as specified on the drawing.

Where possible staggering of Solder Sleeves is recommended to keep any increase in the cable bundle diameter to a minimum.

#### 5.1 Straight Tinel™ Adaptor with 202CXXX

##### 5.1.1 Straight Tinel™ Adaptor with 202C611

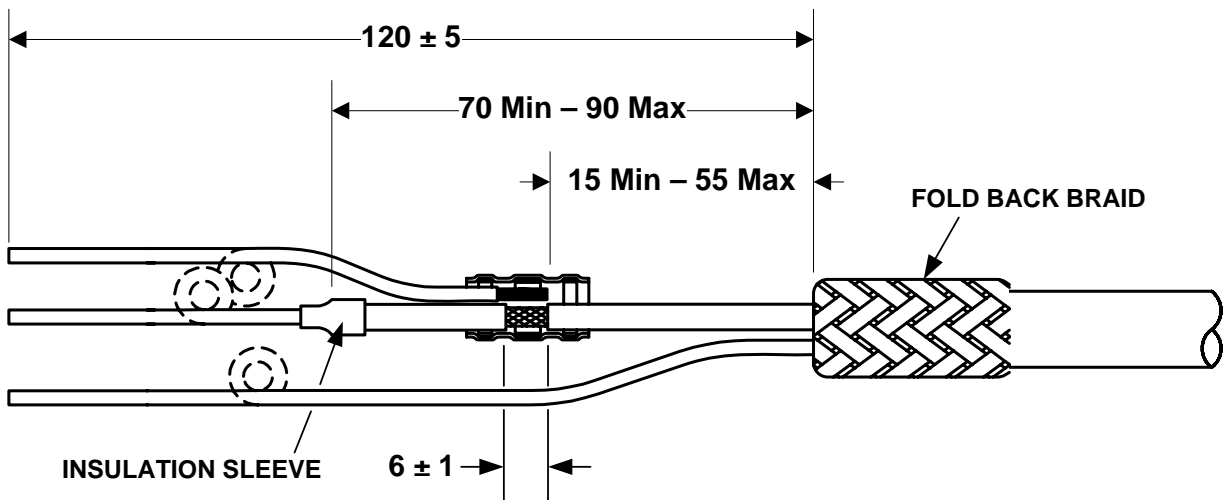

##### 5.1.2 Straight Tinel™ Adaptor with 202C621

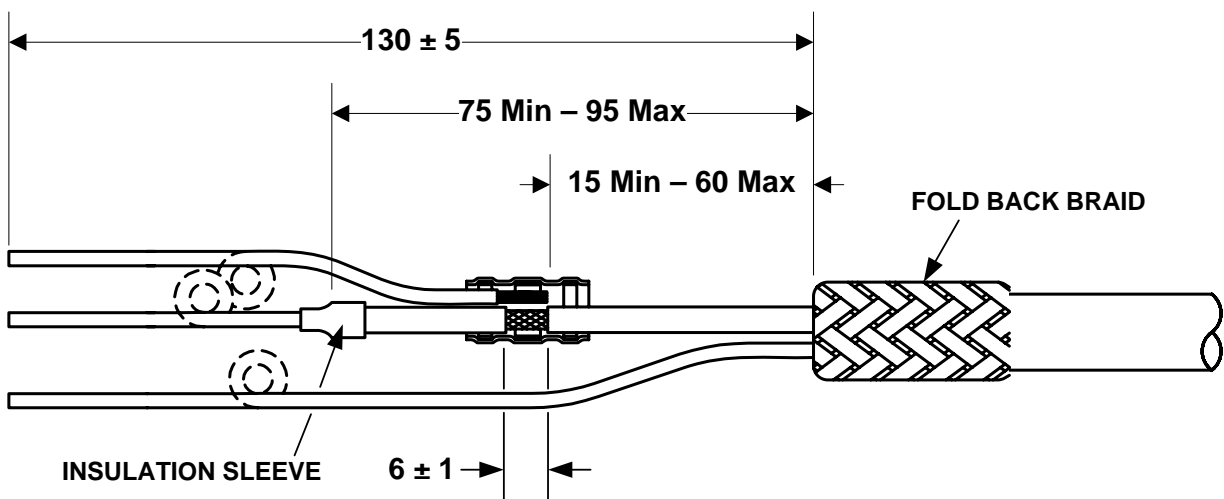

## ELE-3COP-259

Title – Cable preparation when using 202C6XX Uniboot Moulded Parts with Tinel™ Adaptors.

### 5.1.3 Straight Tinel™ Adaptor with 202C632

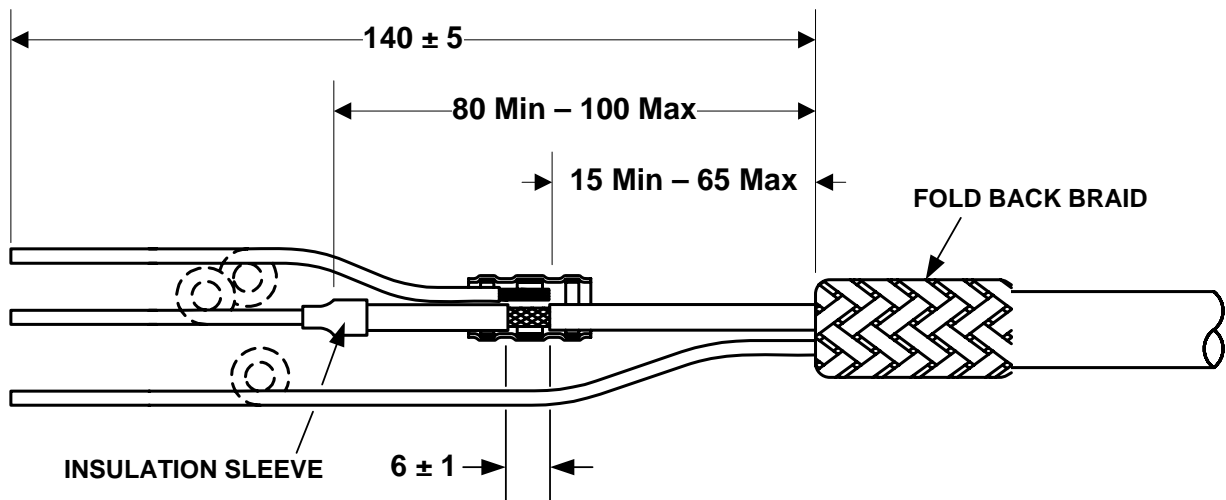

### 5.1.4 Straight Tinel™ Adaptor with 202C642

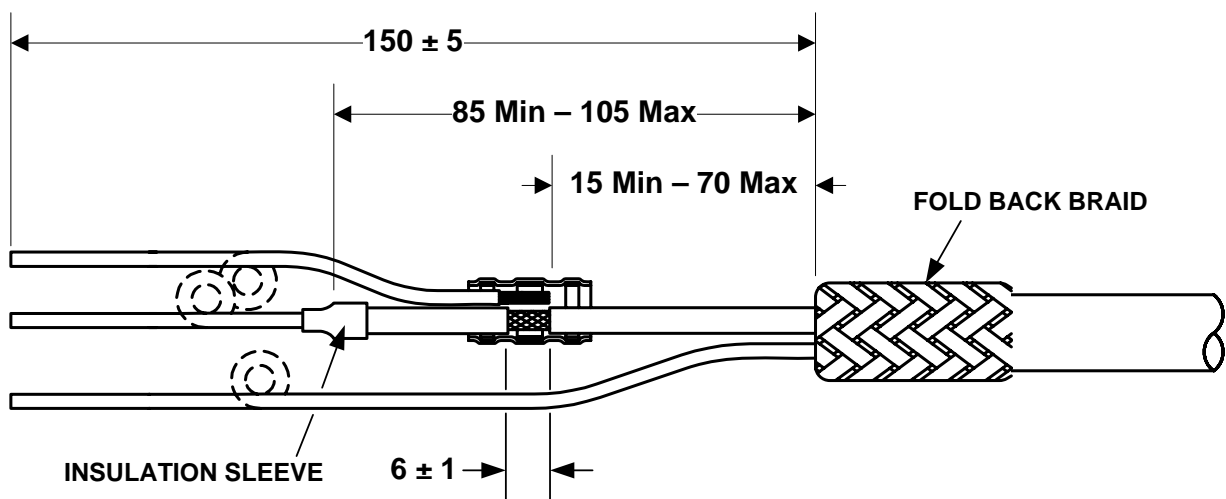

# ELE-3COP-259

Title – Cable preparation when using 202C6XX Uniboot Moulded Parts with Tinel™ Adaptors.

## 5.1.5 Straight Tinel™ Adaptor with 202C653

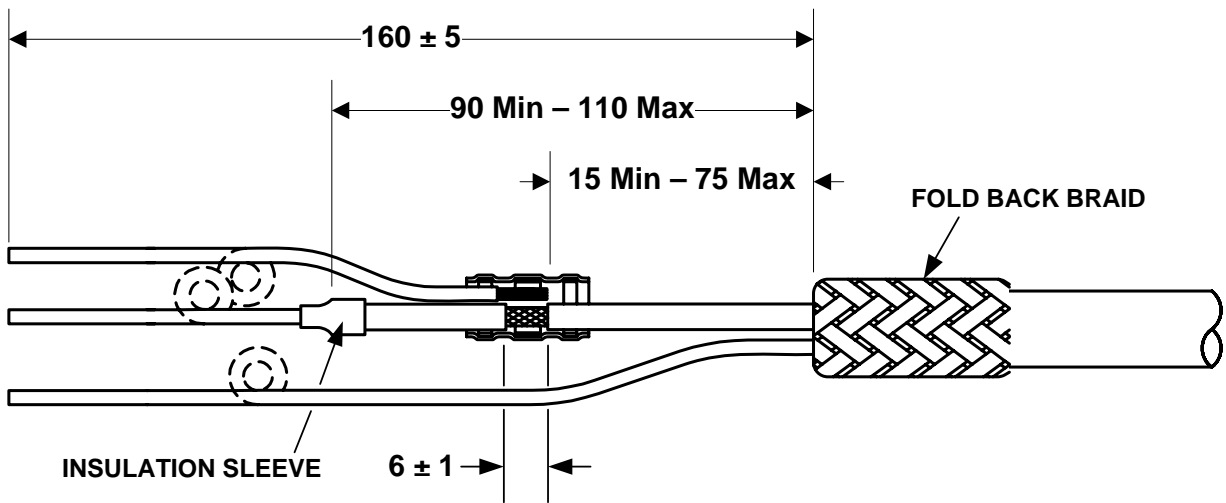

## 5.2 90° Tinel™ Adaptor with 202CXXX

### 5.2.1 90° Tinel™ Adaptor with 202C611

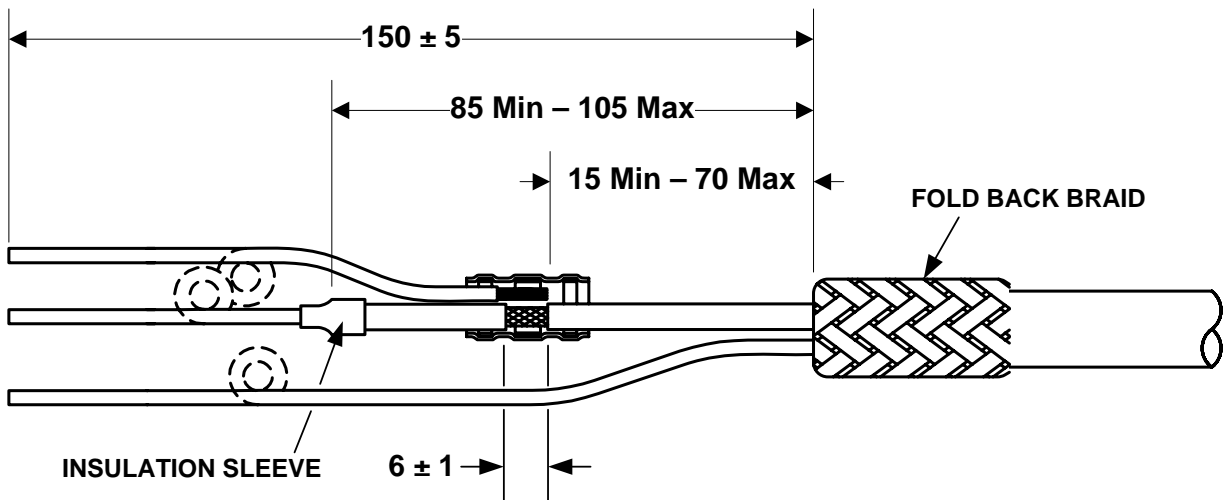

## ELE-3COP-259

Title – Cable preparation when using 202C6XX Uniboot Moulded Parts with Tinel™ Adaptors.

### 5.2.2 90° Tinel™ Adaptor with 202C621

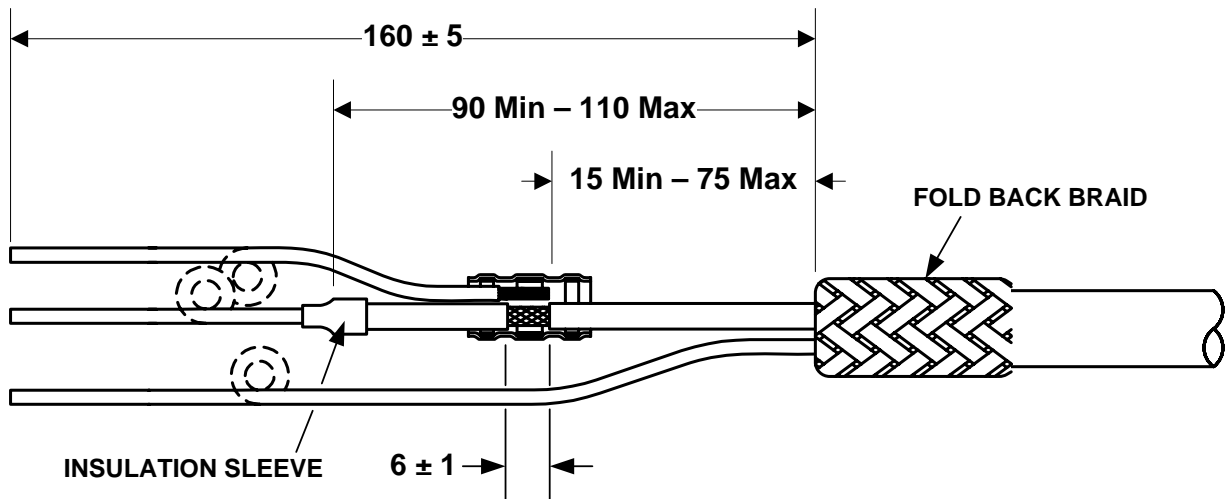

### 5.2.3 90° Tinel™ Adaptor with 202C632

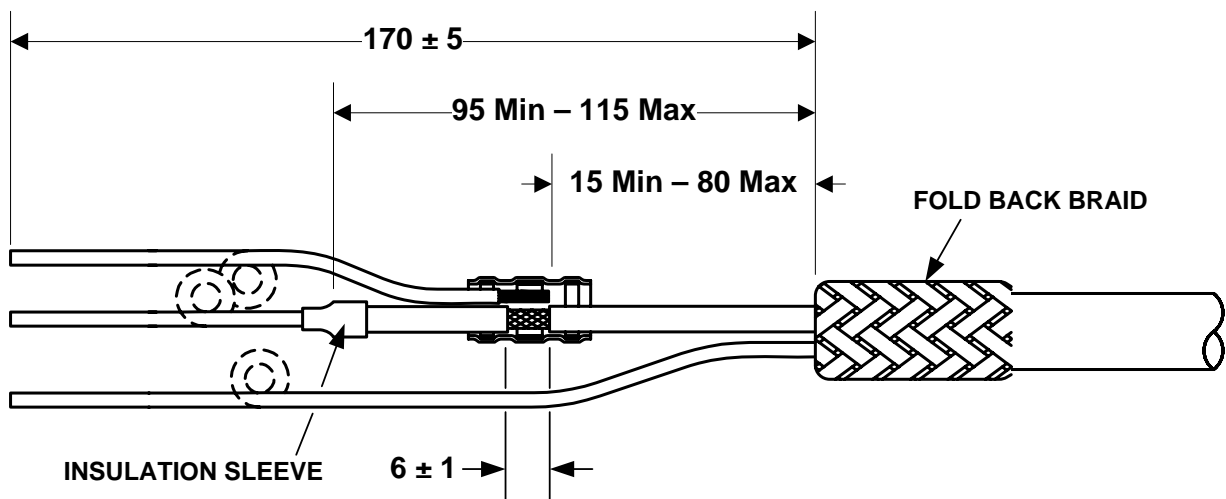

## ELE-3COP-259

Title – Cable preparation when using 202C6XX Uniboot Moulded Parts with Tinel™ Adaptors.

### 5.2.4 90° Tinel™ Adaptor with 202C642

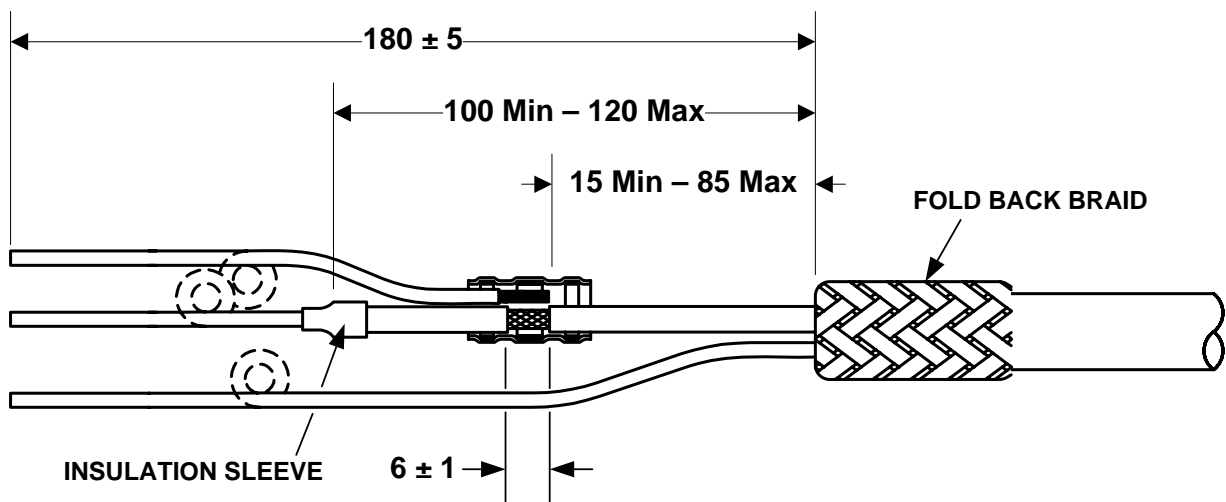

### 5.2.5 90° Tinel™ Adaptor with 202C653

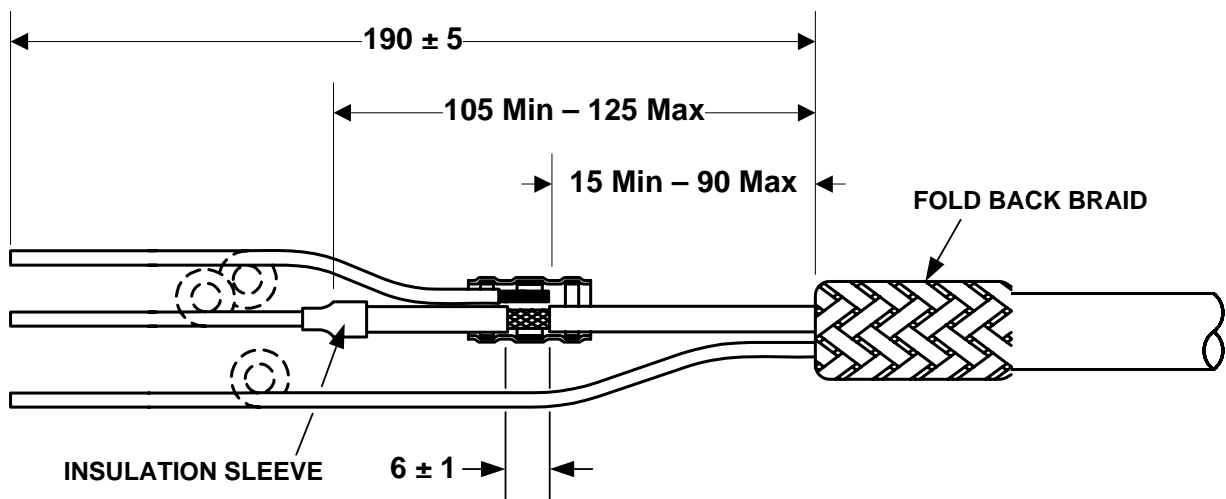

## ELE-3COP-259

Title – Cable preparation when using 202C6XX Uniboot Moulded Parts with Tinel™ Adaptors.

### 5.3 45° Tinel™ Adaptor with 202CXXX

#### 5.3.1 45° Tinel™ Adaptor with 202C611

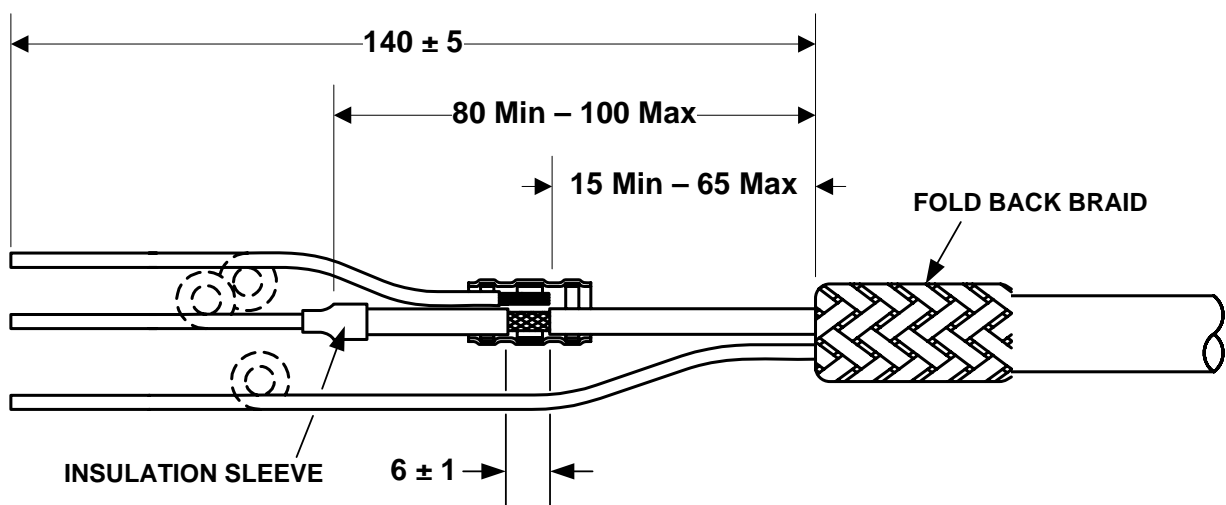

#### 5.3.2 45° Tinel™ Adaptor with 202C621

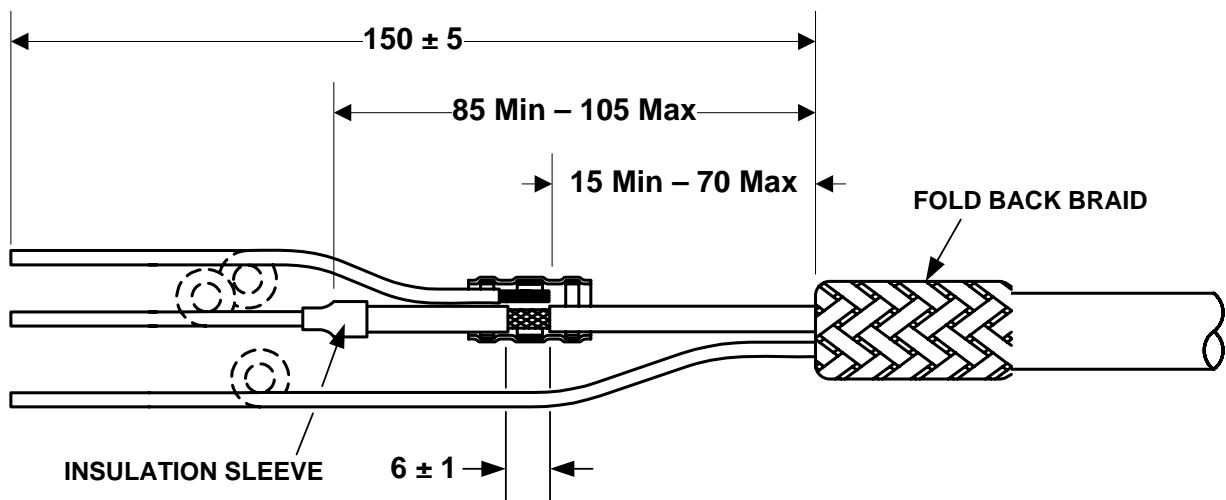

## ELE-3COP-259

Title – Cable preparation when using 202C6XX Uniboot Moulded Parts with Tinel™ Adaptors.

### 5.3.3 45° Tinel™ Adaptor with 202C632

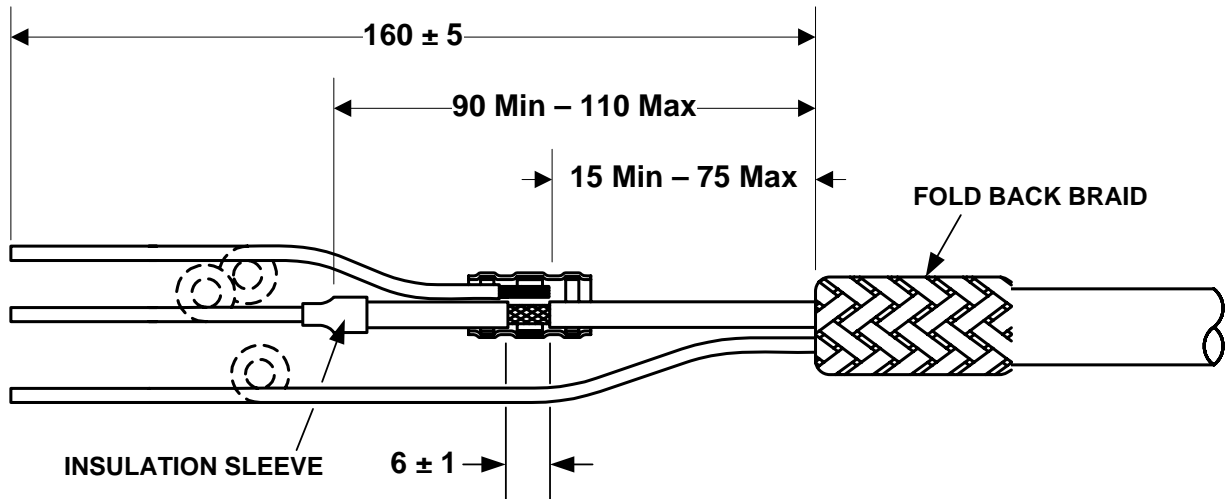

### 5.3.4 45° Tinel™ Adaptor with 202C642

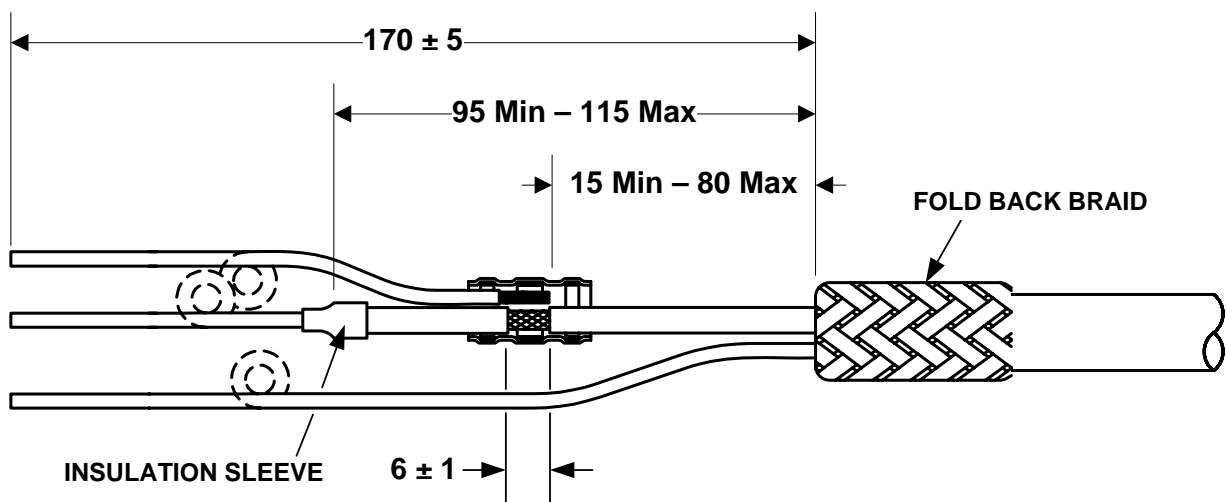



## ELE-3COP-259

Title – Cable preparation when using 202C6XX Uniboot Moulded Parts with Tinel™ Adaptors.

### 5.3.5 45° Tinel™ Adaptor with 202C653

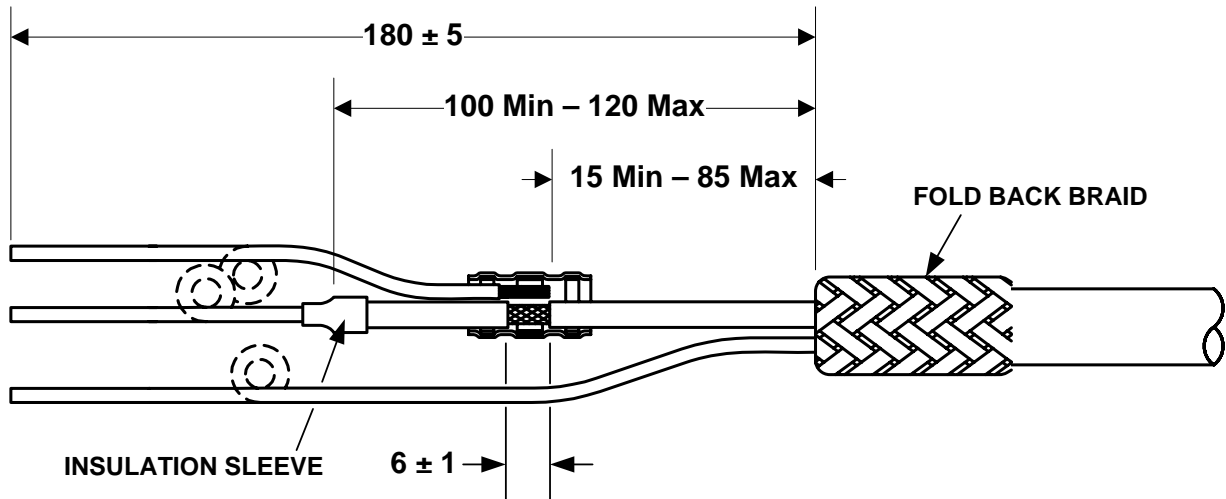

## 6 Inspection Requirements

Refer to documents ELE-3COP-251 and ELE-3COP-254

## 7 Visual Standards

Refer to documents ELE-3COP-251 and ELE-3COP-254

Rev No	CR No	Date	Raised	Approved
1	Initial	22/05/90	Paul Newman	Paul White
2	CR09-DM-018	16/07/10	Paul Newman	Neil Dorricott
3	Visual Identity	06/06/11	Paul Newman	Neil Dorricott

All of the above information is believed to be reliable. Users, however, should independently evaluate the suitability of each product for their application. TE makes no warranties as to the accuracy or completeness of the information and disclaims any liability regarding its use. TE's only obligations are those in the Standard Terms and Conditions of Sale for these products and in no case will TE be liable for any incidental/ indirect or consequential damages arising from the sale, resale, use or misuse of the product. TE Specifications are subject to change without notice. In addition TE reserves the right to make changes in materials or processing, without notification to the Buyer, which do not affect compliance with any applicable specification.