

4

3

2

1

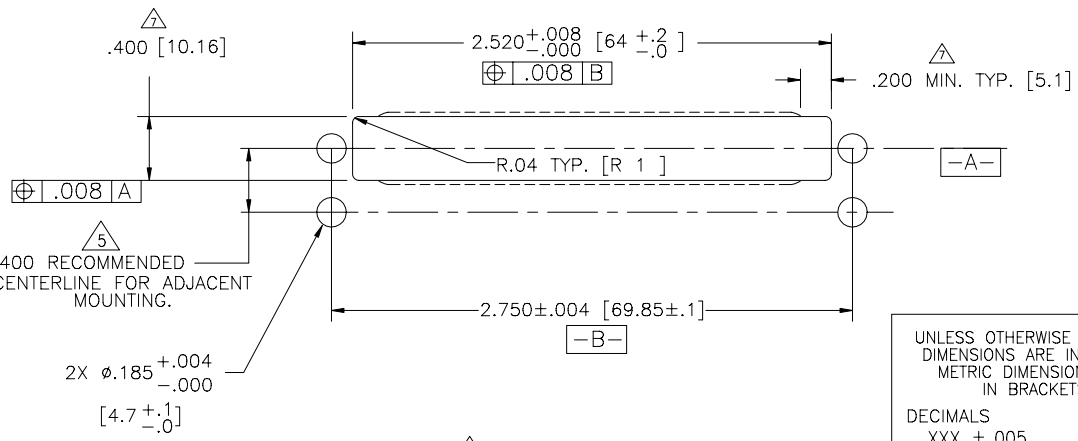
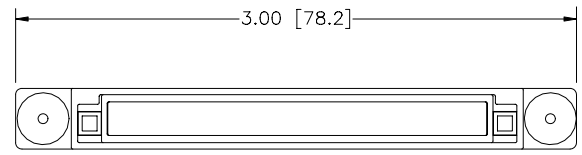
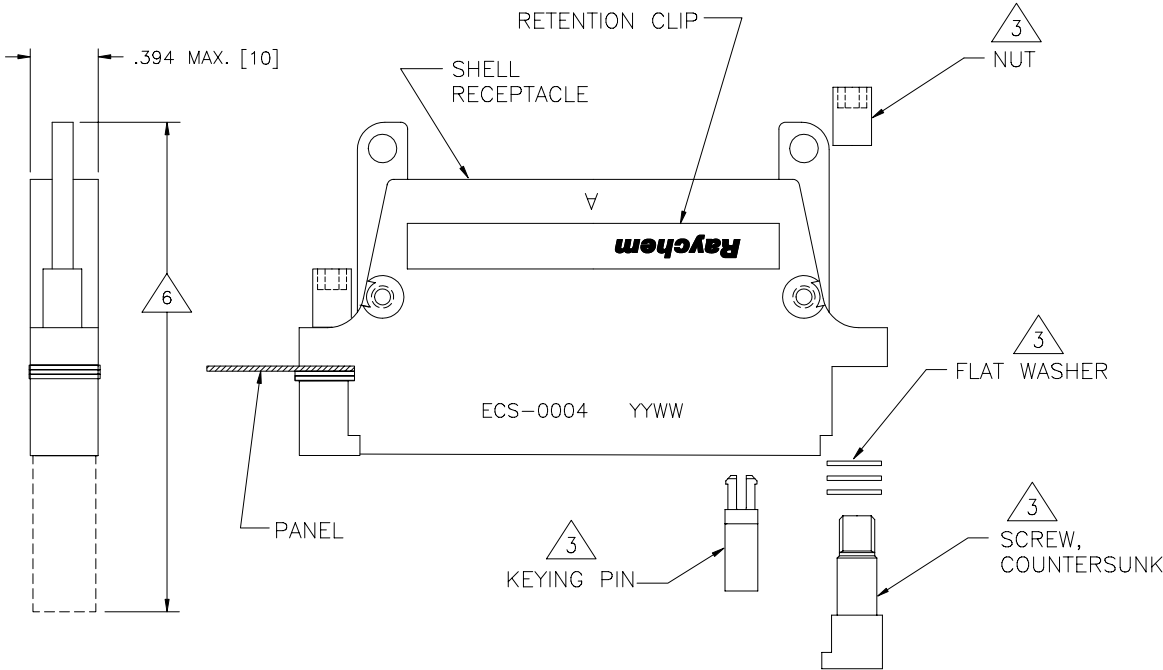

REVISIONS			
LTR	DESCRIPTION	DATE	APPROVED
D	DRAWING HAS BEEN CONVERTED FROM FRENCH PER DCR#1-30272	11/1/2001	M.HIGGY

NOTES:

1. MATERIAL:
- A) SHELL RECEPTACLE ALUMINUM ALLOY PER QQ-A-591
 - B) RETENTION CLIP COPPER ALLOY 172 PER QQ-C-533
 - C) SCREW, COUNTERSUNK STAINLESS STEEL PER QQ-S-763, 300 SERIES
 - D) NUT STAINLESS STEEL PER QQ-S-763, 300 SERIES
 - E) FLAT WASHER STAINLESS STEEL PER QQ-S-763 OR QQ-S-766, 300 SERIES
 - F) KEYING PIN HIGH GRADE POLYARYLENE THERMOPLASTIC, MOLDED

2. FINISH:
- A) SHELL RECEPTACLE CADMIUM PLATED PER QQ-P-416 OVER NICKEL UNDERPLATE
 - B) RETENTION CLIP CADMIUM PLATED PER QQ-P-416
 - C) SCREW, COUNTERSUNK CADMIUM PLATED PER QQ-P-416
 - D) NUT CADMIUM PLATED PER QQ-P-416
 - E) FLAT WASHER CADMIUM PLATED PER QQ-P-416

- 3 THESE ITEMS ARE SUPPLIED UNASSEMBLED.
- 4 THIS RECEPTACLE IS REAR PANEL MOUNTED BY REMOVING AS MANY PANEL WASHERS AS REQUIRED TO ACCOMMODATE THE THICKNESS OF THE PANEL BEING USED. (SEE TABLE I)
- 5 PANEL CUT OUT FOR STACKING CONDITION MAY VARIES, DEPENDING ON THE APPLICATION.
- 6 MATING PLUGS:
ECS-0002 OVERALL LENGTH MEASURES 2.36 [60]
ECS-0003 OVERALL LENGTH MEASURES 2.56 [65]
- 7 THE DIMENSION OF .400 WIDTH MUST BE MAINTAINED FOR .200 MINIMUM LENGTH EACH SIDE FOR PROPER ALIGNMENT. AFTER THAT VARIATION IN .400 DIMENSION IS PERMISSIBLE.

PANEL THICKNESS	NUMBER OF PANEL WASHERS FOR EACH FASTENER
0.031/0.036 [0.8]/[0.9]	2
0.062/0.067 [1.5]/[1.7]	1
0.093/0.097 [2.3]/[2.4]	0

SPECIFICATION CONTROL DRAWING

UNLESS OTHERWISE SPECIFIED DIMENSIONS ARE IN INCHES. METRIC DIMENSIONS ARE IN BRACKETS. DECIMALS .XXX ± .005 { .13 mm } .XX ± .02 { .5 mm } ANGLES .X ± WEIGHT: .057 Lb [26.0] GRAMS	DRAWN	ZS.ORBAN	10/29/2001	TUJCO/ Electronics/Raychem	WIRE AND HARNESSING PRODUCTS 307 CONSTITUTION DRIVE MENLO PARK, CALIFORNIA 94025			
	CHECKED				TITLE	2-INCH BLIND MATING RECEPTACLE MTC SERIES		
	APPROVED	M.HIGGY	10/29/2001	RPN:	SIZE	CODE IDENT. NO.	DWG. NO.	REV
	CAD NAME	T30272.DWG			C	06090	ECS-0004	D
THIRD ANGLE PROJECTION				DO NOT SCALE THIS DRAWING				

**If this document is printed it becomes uncontrolled.
Check with the web for latest revision.**

4

3

2

1

SHEET 1 OF 1
ECS-0004