

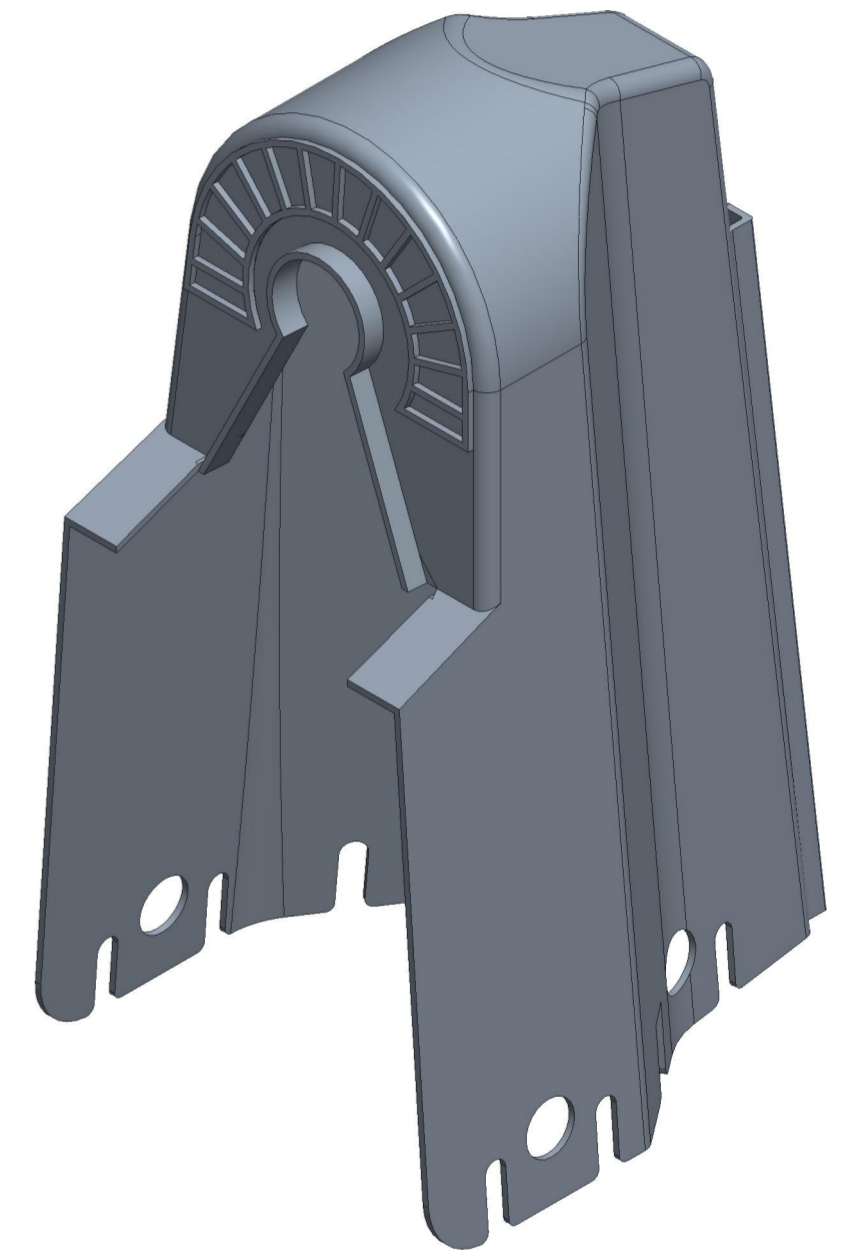

P	LTR	DESCRIPTION	DATE	DWN	APVD
A		INITIAL RELEASE	07JUN2020	AS	LH
AI		REV.PER ECR-24-206030	19MAR2024	MT	LH

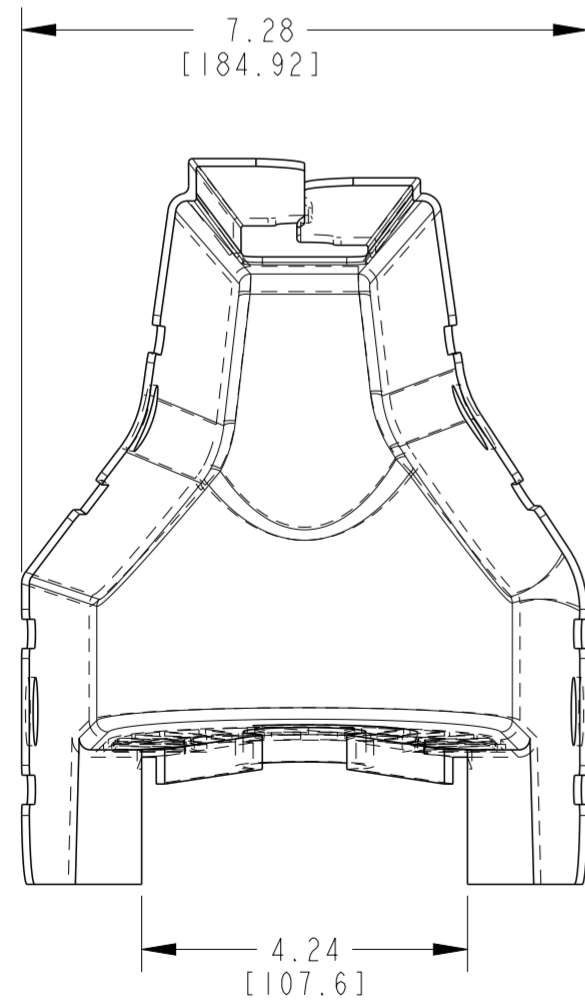
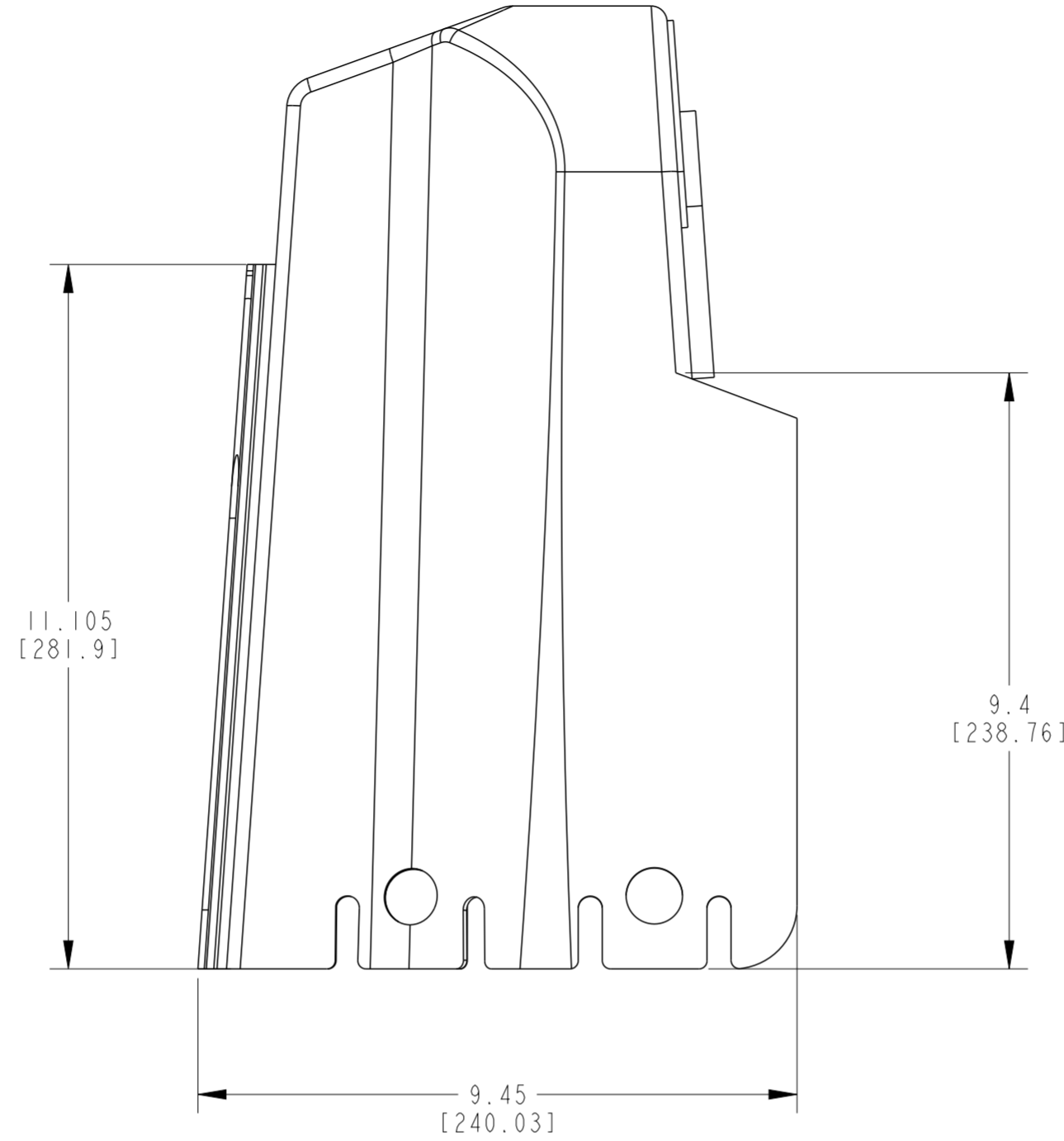
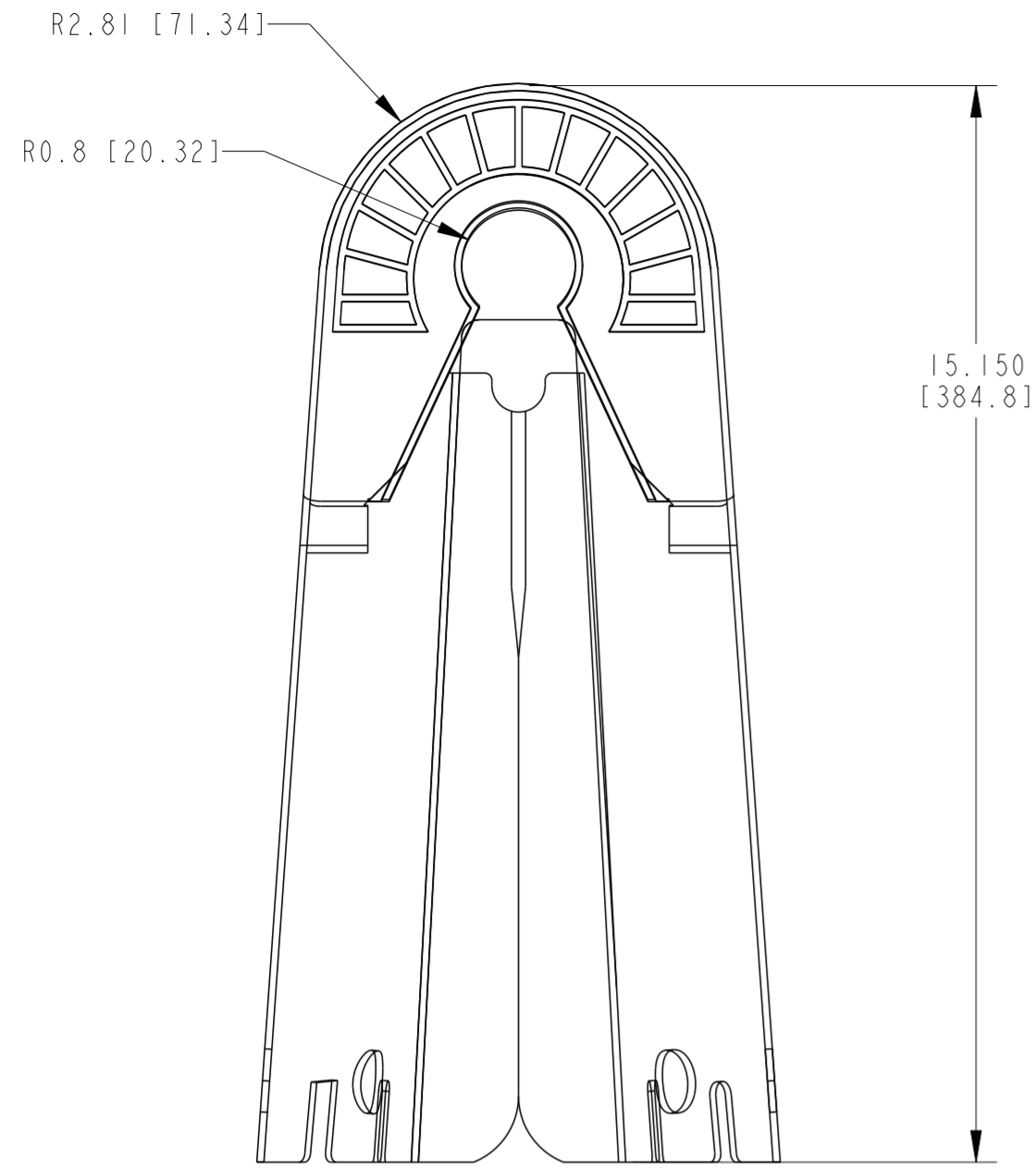

NOTES:

- PARTS SHALL BE KITTED WITH P11-55909.
- EACH BOX SHALL BE LABELLED WITH DESCRIPTION LOT NUMBER PART NUMBER MANUFACTURING DATE AND QUANTITY

TCPN	DESCRIPTION	MATERIAL
FG1739-000	BCAC-G-CUTOUT-FT-P (B3)	TE STANDARD GRAY
ES3101-000	BCAC+G-CUTOUT-FT-P(B3)	TE STANDARD GRAY VO

THIS DRAWING IS A CONTROLLED DOCUMENT.		DWN A. SABARAD 07JUN2020	 TE Connectivity	
DIMENSIONS: MM (INCH)		CHK S. LIGHT 07JUN2020		
TOLERANCES UNLESS OTHERWISE SPECIFIED:		APVD L. HILLER 07JUN2020	NAME BCAC-G-CUTOUT-FT-P (B3)	
0 PLC ± 1 PLC ± 2 PLC ± 3 PLC ± 4 PLC ± ANGLES ± FINISH		PRODUCT SPEC -	RESTRICTED TO -	
MATERIAL		APPLICATION SPEC	SIZE A2	CAGE CODE 00779
		WEIGHT	DRAWING NO E00000903	
		CUSTOMER DRAWING	SCALE NTS	SHEET OF
			REV AI	