

P	LTR	DESCRIPTION	DATE	DWN	APVD
A		INITIAL RELEASE	30MAY2020	AS	LH
AI		REVISED PER ECN-24-273630	10MAY2024	MT	LH

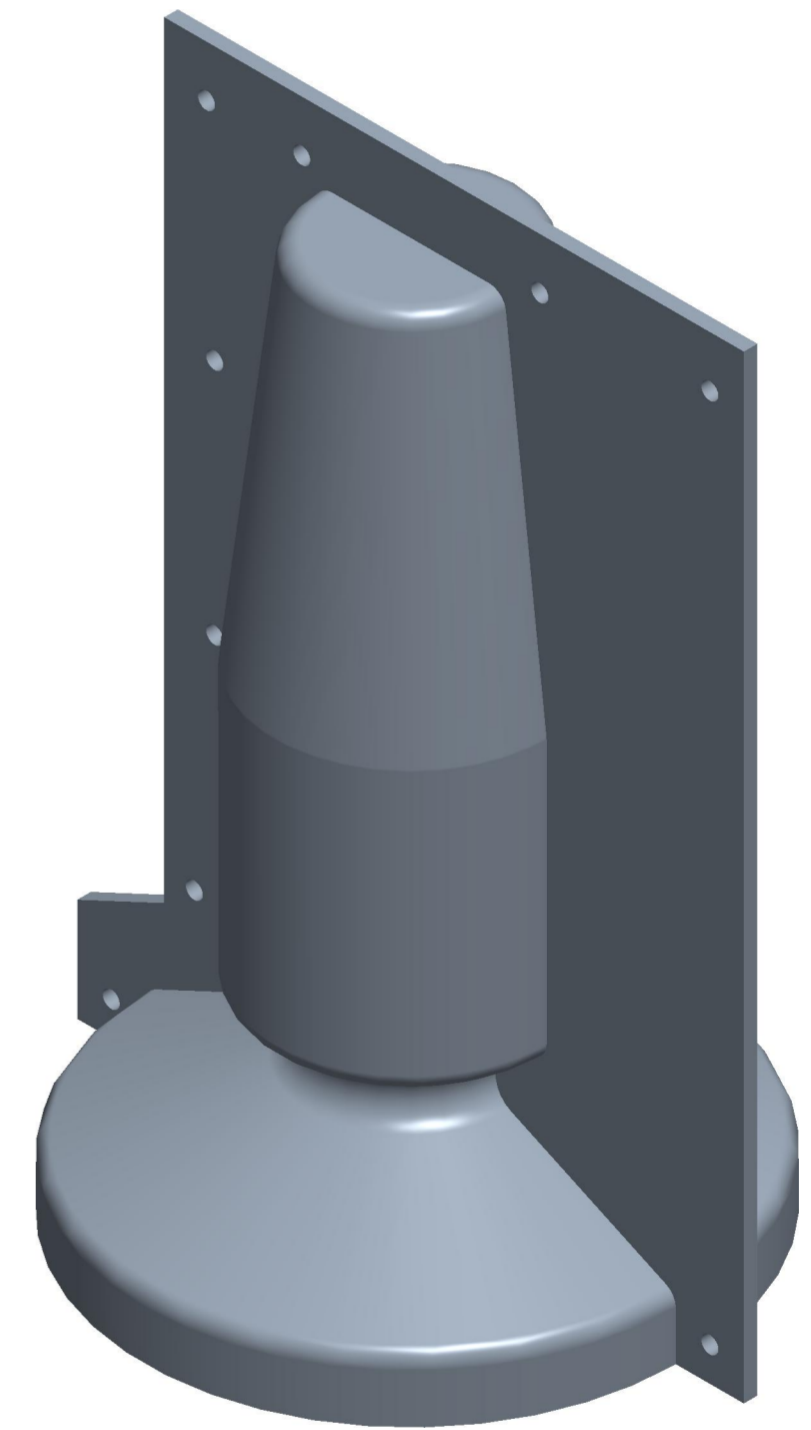
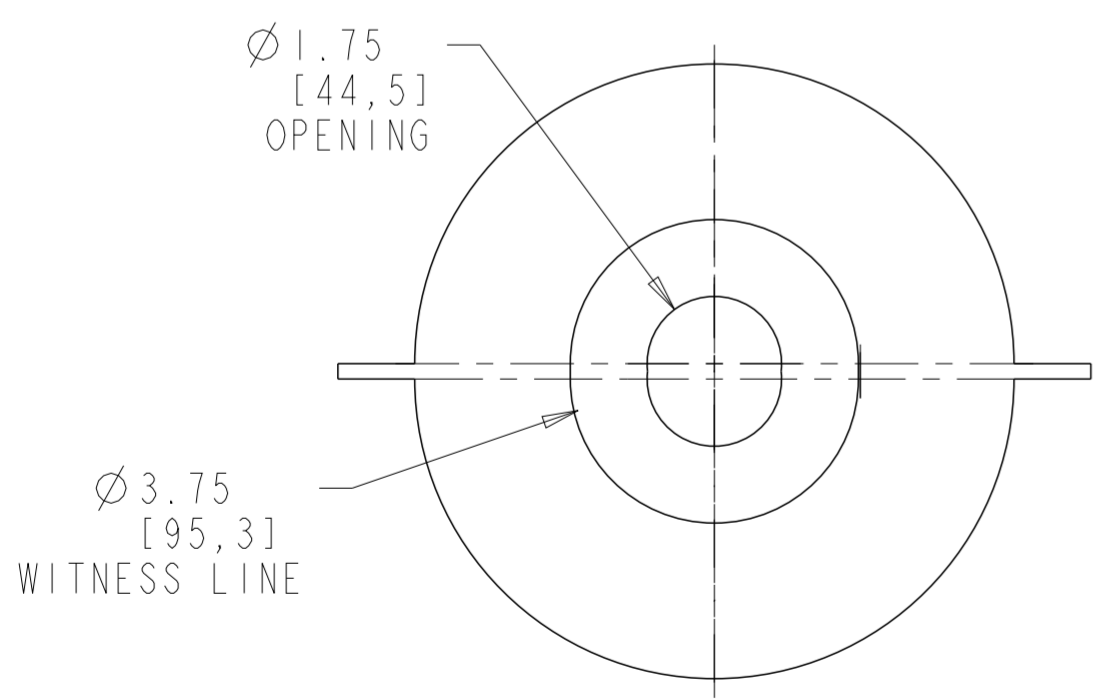
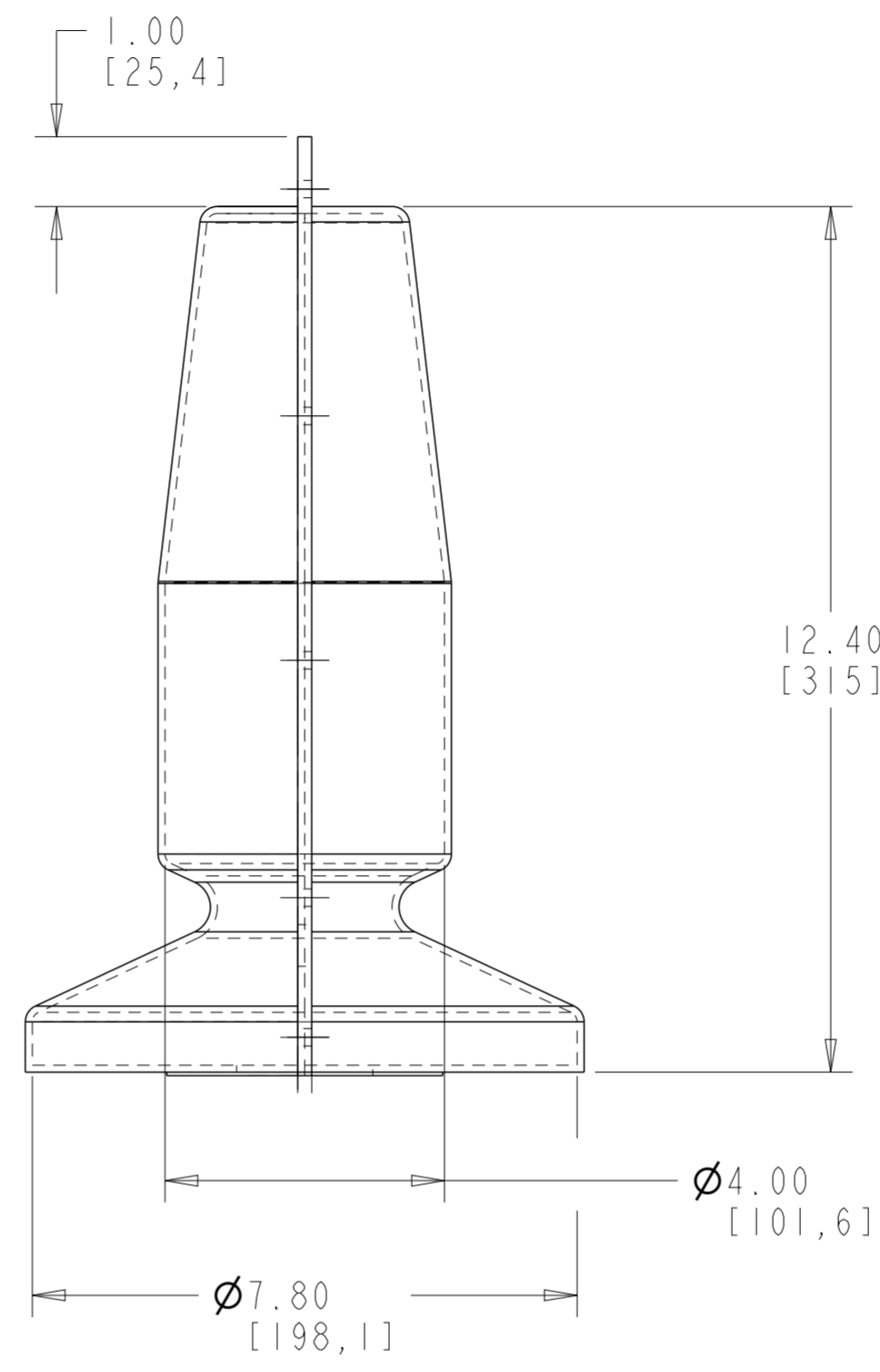
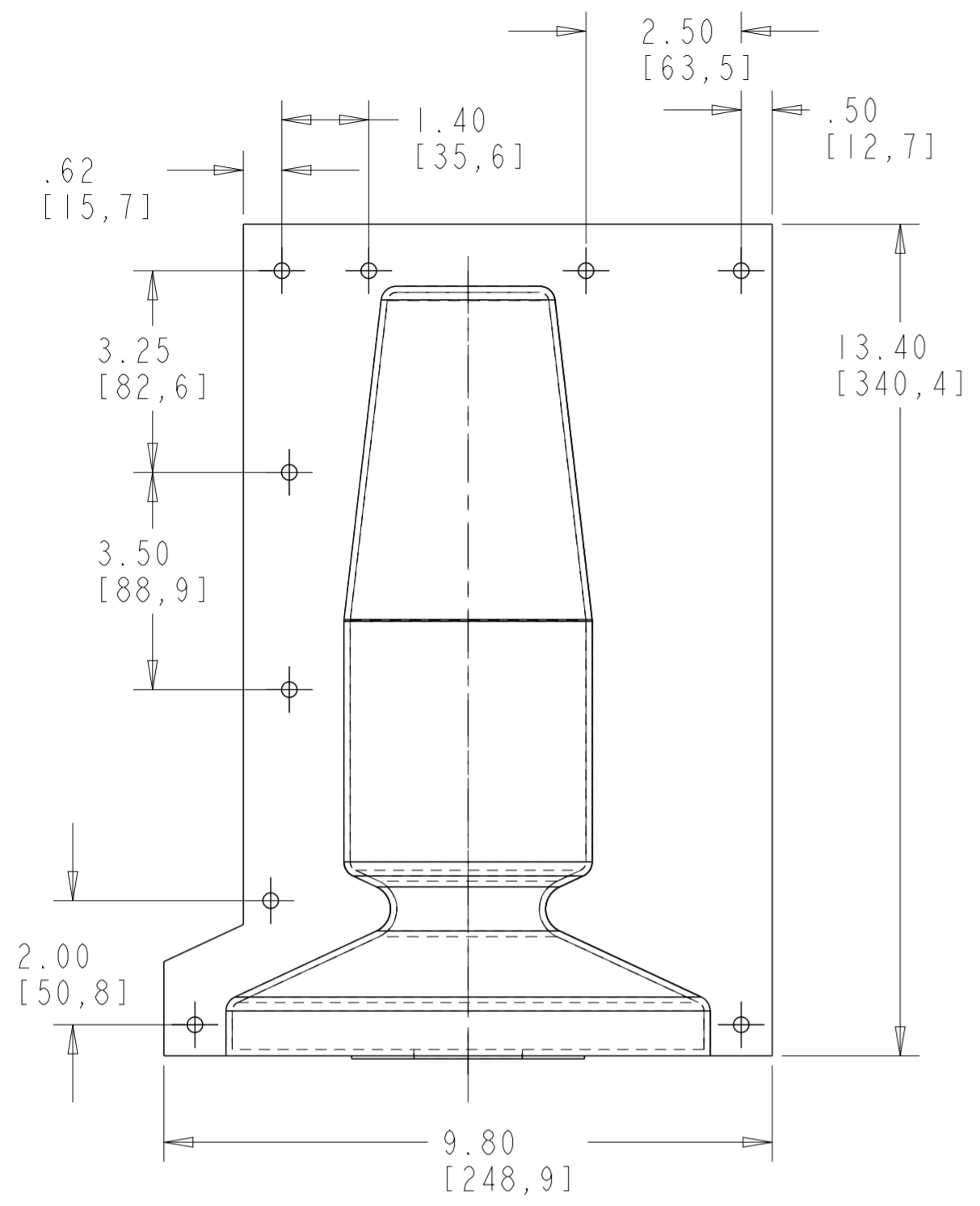

- NOTES:
- PARTS SHALL BE KITTED 6 PIECES PER BOX.
 - PART SHALL BE KITTED WITH QTY 9 BCIC LATCH, PN 607477-000
 - EACH BOX SHALL BE LABELLED WITH DESCRIPTION, LOT NUMBER, PART NUMBER, MANUFACTURING DATE AND QUANTITY

TCPN	DESCRIPTION	MATERIAL
CR6675-000	BCIC-G-RECLOSERCOVER(B6)	TE STANDARD GRAY
ES3145-000	BCIC+G-RECLOSERCOVER(B6)	TE STANDARD GRAY V0
CF1720-000	BCIC-RECLOSERCOVER(B6)	TE STANDARD RED

THIS DRAWING IS A CONTROLLED DOCUMENT.

DWN A. SABARAD 30MAY2020	 TE Connectivity NAME: BCIC-G-RECLOSERCOVER(B6)
CHK S. LIGHT 30MAY2020	
APVD L. HILLER 30MAY2020	
PRODUCT SPEC	
DIMENSIONS: INCH(MM)	TOLERANCES UNLESS OTHERWISE SPECIFIED:
0 PLC ±	1 PLC ±0.1
1 PLC ±0.1	2 PLC ±0.01
2 PLC ±0.01	3 PLC ±0.001
3 PLC ±0.001	4 PLC ±0.0001
4 PLC ±0.0001	ANGLES ±
MATERIAL	FINISH
-	-
-	-

SIZE	CAGE CODE	DRAWING NO	RESTRICTED TO
A2	00779	C-E00000850	-
CUSTOMER DRAWING	SCALE	NTS	SHEET OF
			REV AI