

THIS DRAWING IS UNPUBLISHED. RELEASED FOR PUBLICATION 20  
 © COPYRIGHT 20 BY - ALL RIGHTS RESERVED.

REVISIONS				
P	LTR	DESCRIPTION	DATE	APVD
B		LC20-0068-18 / ECO-18-010286	26JUN2018	DM BJ

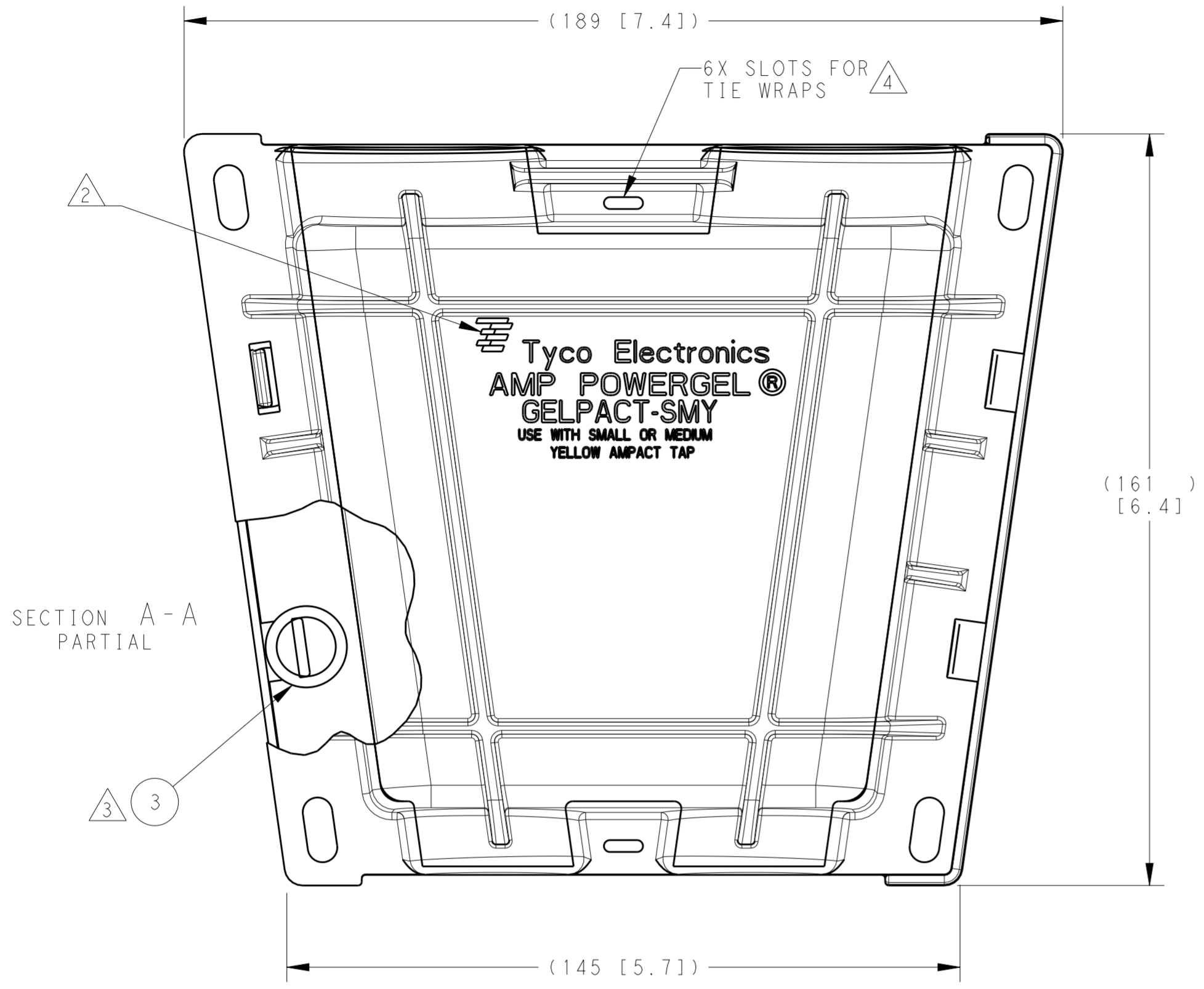

- ACCOMMODATES:  
AMPACT TAP CONNECTOR SIZES 336.4 KCMIL SERIES TO 556.5 KCMIL SERIES.
- MARKING ON PART:  
[OLD TE LOGO]  
Tyco Electronics  
GELPACT SMY  
AMP POWERGEL  
USE WITH SMALL OR MEDIUM  
YELLOW AMPACT TAP
- REMOVE O-RINGS (ITEM 3) BEFORE ASSEMBLING COVERS (ITEM 1) AT SNAP FITS.
- TIE WRAPS (ITEM 2) MUST BE INDIVIDUALLY ASSEMBLED ON TO EACH SLOT OF ASSEMBLED COVERS (ITEM 1). TIE WRAPS NOT SHOWN ON DWG.

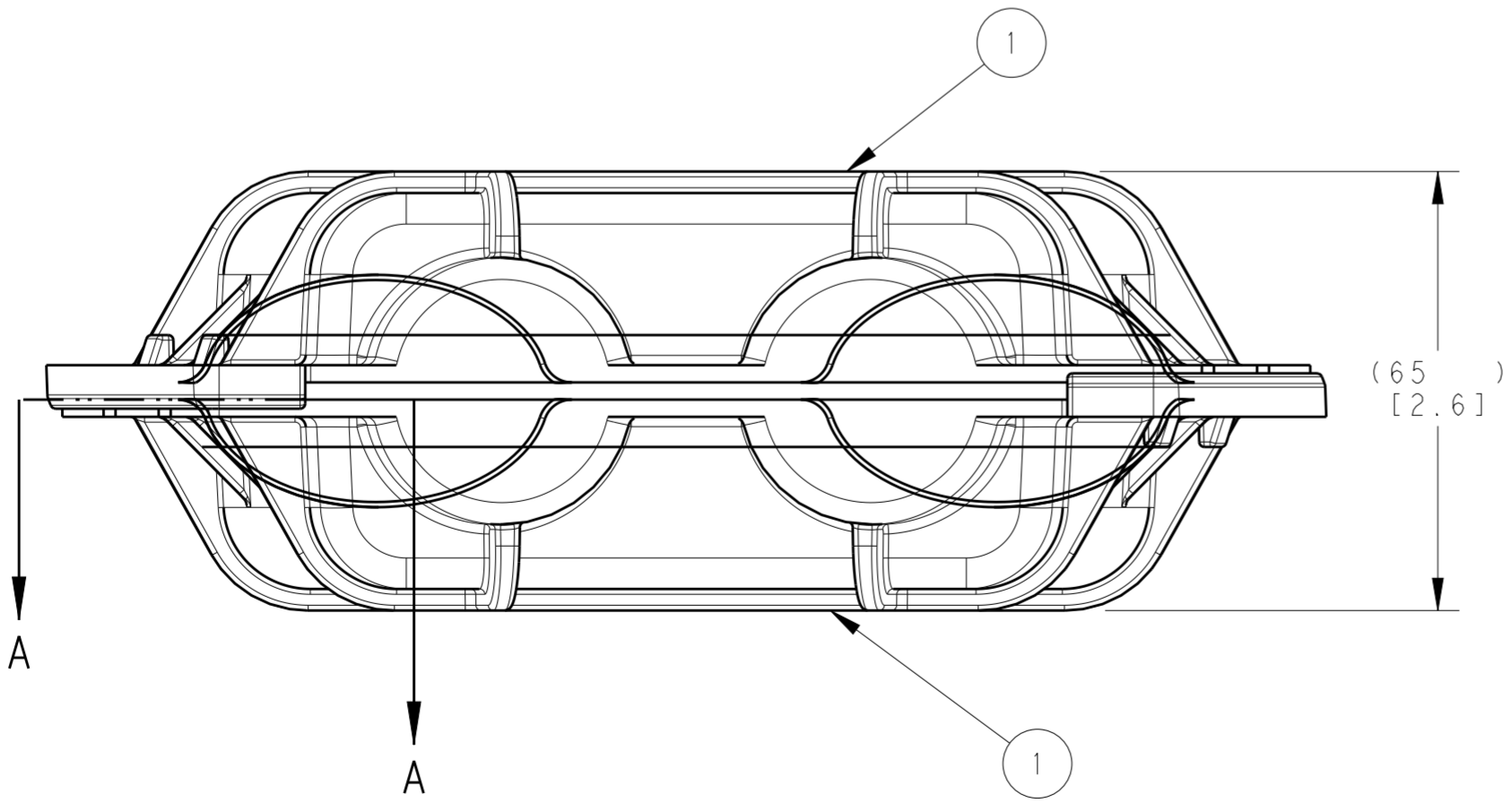

GELPACT SMY	1710501-1
CATALOG NO	PART NO

1/BOX	INSTALLATION & SAFTY INSTRUCTION SHEET	4
4	O-RING, ID X OD = 1/2 X 11/16	3
6	TIE WRAP, 14.5X.300, 120 lbs CAPACITY	2
2	GELPACT SMY COVER W/ GEL, AMPACT TAP CONNECTOR SIZES 336.4-556.5 KCMIL	1
-1	DESCRIPTION	ITEM NO
QTY	PARTS LIST	

THIS DRAWING IS A CONTROLLED DOCUMENT.		DWN 26 JUN 2018 D. MURUGIAH	TE Connectivity
DIMENSIONS: mm [inch]		CHK 09 JUL 2018 S. RAHMAN	
TOLERANCES UNLESS OTHERWISE SPECIFIED:		APVD 11 JUL 2018 B. JOHNSON	NAME GELPACT SMY COVER WITH GEL, AMPACT TAP SIZES 336.4-556.5 KCMIL
0 PLC ± 1 PLC ± 2 PLC ± 3 PLC ± 4 PLC ± ANGLES ± FINISH -		PRODUCT SPEC -	SIZE CAGE CODE DRAWING NO RESTRICTED TO A200779 C-1710501
MATERIAL SEE BOM		APPLICATION SPEC -	SCALE 1:1 SHEET 1 OF 1 REV B
		WEIGHT -	CUSTOMER DRAWING