

DRAWING NO: NGA0950-1025-C
THIS DRAWING IS A CONTROLLED DOCUMENT



ARMOUR RODS

CATALOGUE NUMBER: NGA0950-1025 SUITS CONDUCTOR

STRANDING	COND. TYPE	DIAMETER	FITTING LAY
7/3.25 (7/10)	SC/GZ	9.75	RIGHT HAND
19/2.00 (19/14)	SC/GZ	10.00	RIGHT HAND

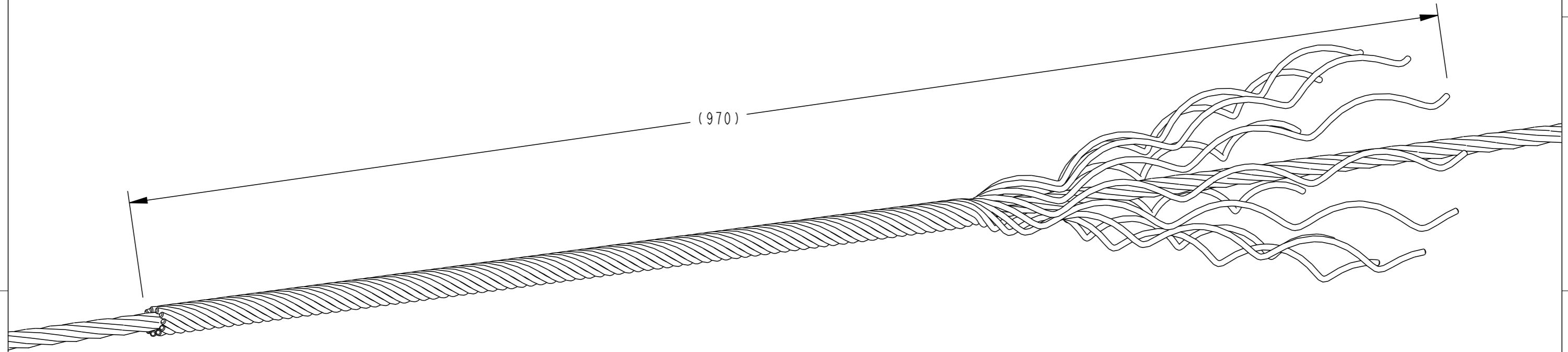

TECHNICAL SPECIFICATIONS;

CATALOGUE NUMBER: NGA0950-1025
DESCRIPTION: NON-TENSION GALVANIZED STEEL ARMOUR RODS
MATERIAL: HEAVILY GALVANIZED STEEL WIRE.
NUMBER OF RODS: 11
ROD DIAMETER: 2.95mm
OVERALL LENGTH: 970mm
END FINISH: CHAMFERED
FITTING LAY DIRECTION: RIGHT HAND
COLOUR CODED: ORANGE/YELLOW
RODS ARE LABELED, BUNDLED IN A SET AND TAPED AT BOTH ENDS.

BOX LABEL

P/N: NGA0950-1025
ID:
DESCRIPTION:
NON-TENSION GALV-STEEL ARMOUR RODS
7/3.25 (7/10) SC/GZ
19/2.00 (19/14) SC/GZ
RANGE: 9.50 - 10.25
COLOUR-CODE: ORANGE/YELLOW
QTY: 20 WEIGHT: BATCH:

PRODUCT LABEL

NGA0950-1025
7/3.25 (7/10) SC/GZ
19/2.00 (19/14) SC/GZ

WEIGHT: 0.61 kg
BATCH NO:
MONTH/YEAR:

THIS INFORMATION IS CONFIDENTIAL AND PROPRIETARY TO TE CONNECTIVITY CORPORATION AND ITS WORLDWIDE SUBSIDIARIES AND AFFILIATES. IT MAY NOT BE DISCLOSED TO ANYONE, OTHER THAN TE CONNECTIVITY PERSONNEL, WITHOUT WRITTEN AUTHORIZATION FROM TE CONNECTIVITY CORPORATION, AUSTRALIA.

LOC							IMPLIED NOTES BURRS AND SHARP EDGES REMOVED SCREW THREADS ARE TO AS 1275 DO NOT WORK TO DIMS MARKED REF SURFACE FINISH 6.3 U.N.O. DIMS ARE IN mm. DO NOT SCALE	IMPLIED TOLERANCES HOLE DIA AND LOCATIONS. ±0.5mm DIMENSIONS UP TO 30mm. ±1.5mm DIMENSIONS OVER 30mm. ±5% UP TO A MAX OF. ±5mm ANGULAR DIMENSIONS. ±5°	TCPN - PART Alias UTX/DUL NGA0950-1025 Cat No NGA0950-1025	TITLE NON-TENSION GALV-STEEL ARMOUR RODS (NGA) FITTING COND RANGE: Ø 9.50 - Ø 10.25				
DIST	—	I	NEW RELEASE	27-03-2014	AG	AT	MATERIAL DESC HEAVILY GALVANIZED STEEL WIRE			DRAWN AG	DATE 27-03-2014	TE Connectivity 2/3 Corella Close Berkeley Vale NSW 2261 Australia		
POS	REV	REVISION RECORD		DATE	DWN	APVD	MATERIAL NO -	MATL SPEC/STD/DRG NO -	PROCESS SPEC HEAT TREAT/PLATING NO -	CHECKED RN	APPROVED AT			

8

7

6

5

Format: generic_m03.au.r1.frm 4

Template: tec_generic_a3_metric.au.r1.drw 3

Dwg No from P1 Mod Fam Tbl: 2 >AUXXXXX

1