

**SAFETY ORGANIZATIONS**

THIS FILTER HAS BEEN FORMALLY RECOGNIZED, CERTIFIED OR APPROVED BY THE LISTED AGENCY. THEREFORE, ALL TEST/REQUIREMENTS SPECIFIED IN THE LATEST REVISION OF THE FOLLOWING AGENCY STANDARDS HAVE BEEN MET:

- UL RECOGNIZED: UL 1283
- CSA CERTIFIED: CSA 22.2, No. 8
- VDE APPROVED: EN 60939-2

**OPERATING SPECIFICATIONS**

LINE CURRENT/VOLTAGE: 6 AMP, 120/250 VAC,  
6 AMP/40°C, 250 VAC

LINE FREQUENCY: 50-60Hz

MAXIMUM LEAKAGE CURRENT,  
EACH LINE TO GROUND: 0.22 mA @ 120V 60Hz  
0.38 mA @ 250V 50Hz

OPERATING AMBIENT TEMP. RANGE: -10°C TO +40°C @ RATED CURRENT, I<sub>r</sub>.

IN AN AMBIENT, T<sub>a</sub>, HIGHER THAN 40°C, THE MAXIMUM OPERATING CURRENT, I<sub>o</sub>, IS AS FOLLOWS:

$$I_o = I_r \sqrt{\frac{85 - T_a}{45}}$$

**RELIABILITY SPECIFICATIONS:**

STORAGE TEMPERATURE: -40°C TO +85°C  
HUMIDITY: 21 DAYS @ 40°C 95% RH.  
CURRENT OVERLOAD TEST: 6 TIMES I<sub>r</sub> FOR 8 SECONDS

**TEST SPECIFICATIONS:**

INDUCTANCE: 0.465 mH NOMINAL  
CAPACITANCE: (MEASURED @ 1KHz, 0.250VAC MAX., 25°C±1°C)  
LINE TO GROUND: 0.0059 µF ±20%  
LINE TO LINE: 0.1015 µF ±20%  
DISCHARGE RESISTOR: 1.5MΩ  
L/G AND L/L I.R.  
NO DISCHARGE RESISTOR: 6000MΩ (MIN.) @ 100VDC, 20°C AND 50% RH

**RECOMMENDED RECEIVING INSPECTION HIPOT:**

LINE TO GROUND: 1500 VAC OR 2250 VDC FOR 1 MINUTE  
LINE TO LINE: 1450 VDC FOR 1 MINUTE

**FILTER APPROVAL:**

THE BEST WAY TO SELECT AND QUALIFY A FILTER IS FOR YOUR ENGINEERING TO TEST THE UNIT IN YOUR EQUIPMENT.

**CUSTOMER DRAWING**

**CATALOG # 6EJS1**

ECN #	APPRVD.	DATE
24-261887	JB	16JAN24

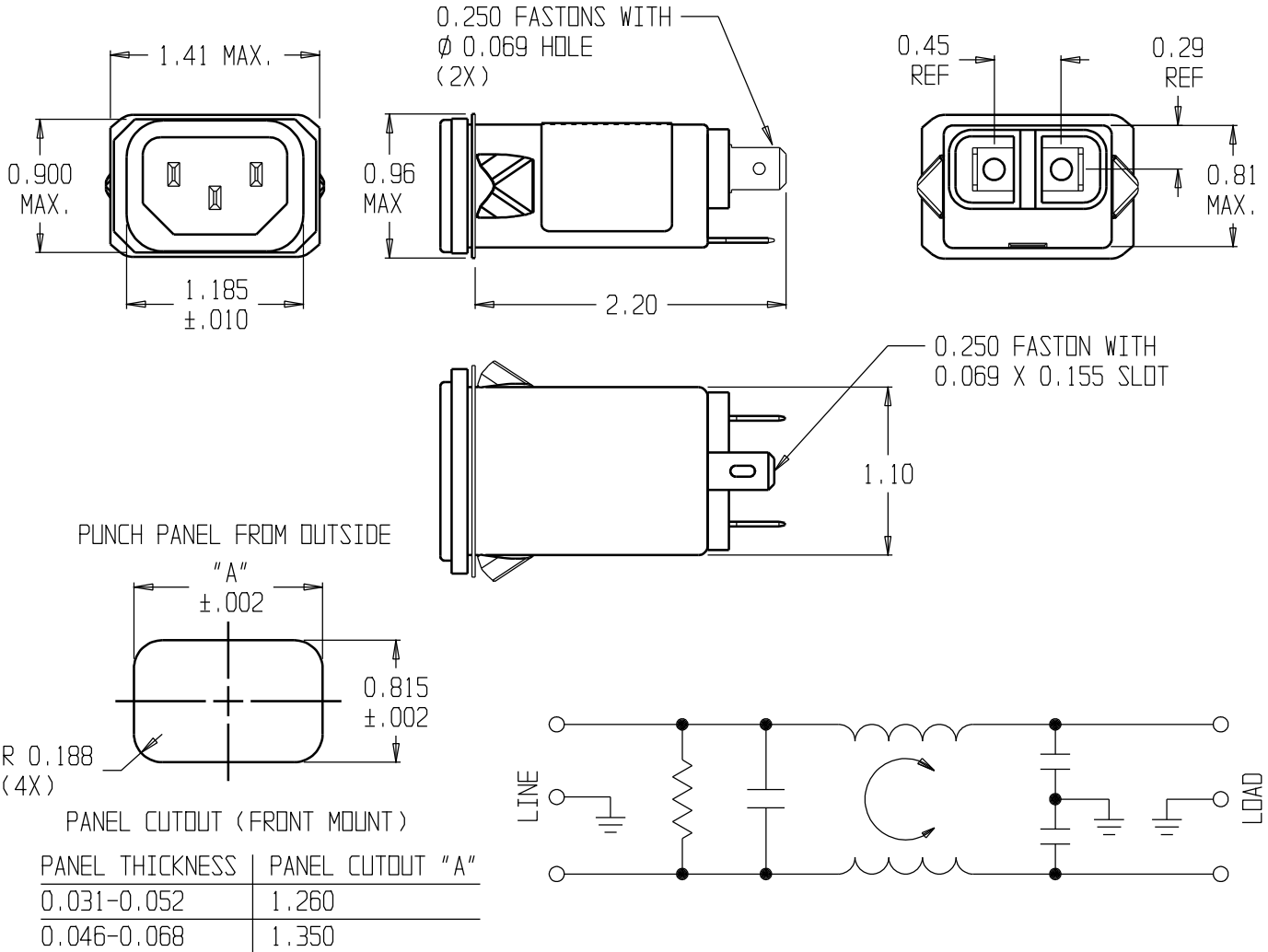

**50Ω - 50Ω (MINIMUM) INSERTION LOSS**

FREQUENCY MHz	.05	0.1	.15	0.5	1	3	5	10	30
COMMON dB	1	5	9	21	28	40	41	44	54
DIFF. dB		5	8	17	21	21	32	40	40

THIRD ANGLE PROJECTION

UNLESS OTHERWISE SPECIFIED, TOLERANCE TO BE ±.025 MATERIAL & FINISH: AS SUPPLIED

THIS INFORMATION IS CONFIDENTIAL AND PROPRIETARY TO TYCO ELECTRONICS CORPORATION AND ITS WORLDWIDE SUBSIDIARIES AND AFFILIATES. IT MAY NOT BE DISCLOSED TO ANYONE OTHER THAN TYCO ELECTRONICS PERSONNEL, WITHOUT WRITTEN AUTHORIZATION FROM TYCO ELECTRONICS CORPORATION. HARRISBURG, PENNSYLVANIA USA



**POWER LINE FILTER**

CAD FILE:	6EJS1-E.ckd	TE PART #:	1-6609006-2
SCALE:	NTS	DATE:	12DEC02
DRW. BY:	SD	DRWG:	PJD
		CATALOG NO.	6EJS1
		REV.	E