

THIS DRAWING IS UNPUBLISHED. RELEASED FOR PUBLICATION
 © COPYRIGHT BY TYCO ELECTRONICS CORPORATION. ALL RIGHTS RESERVED.

LOC	DIST	REVISIONS					
AF	50	P	LTR	DESCRIPTION	DATE	DWN	APVD
		J1		REVISED PER ECR-17-008212	07JUN17	SC	RP

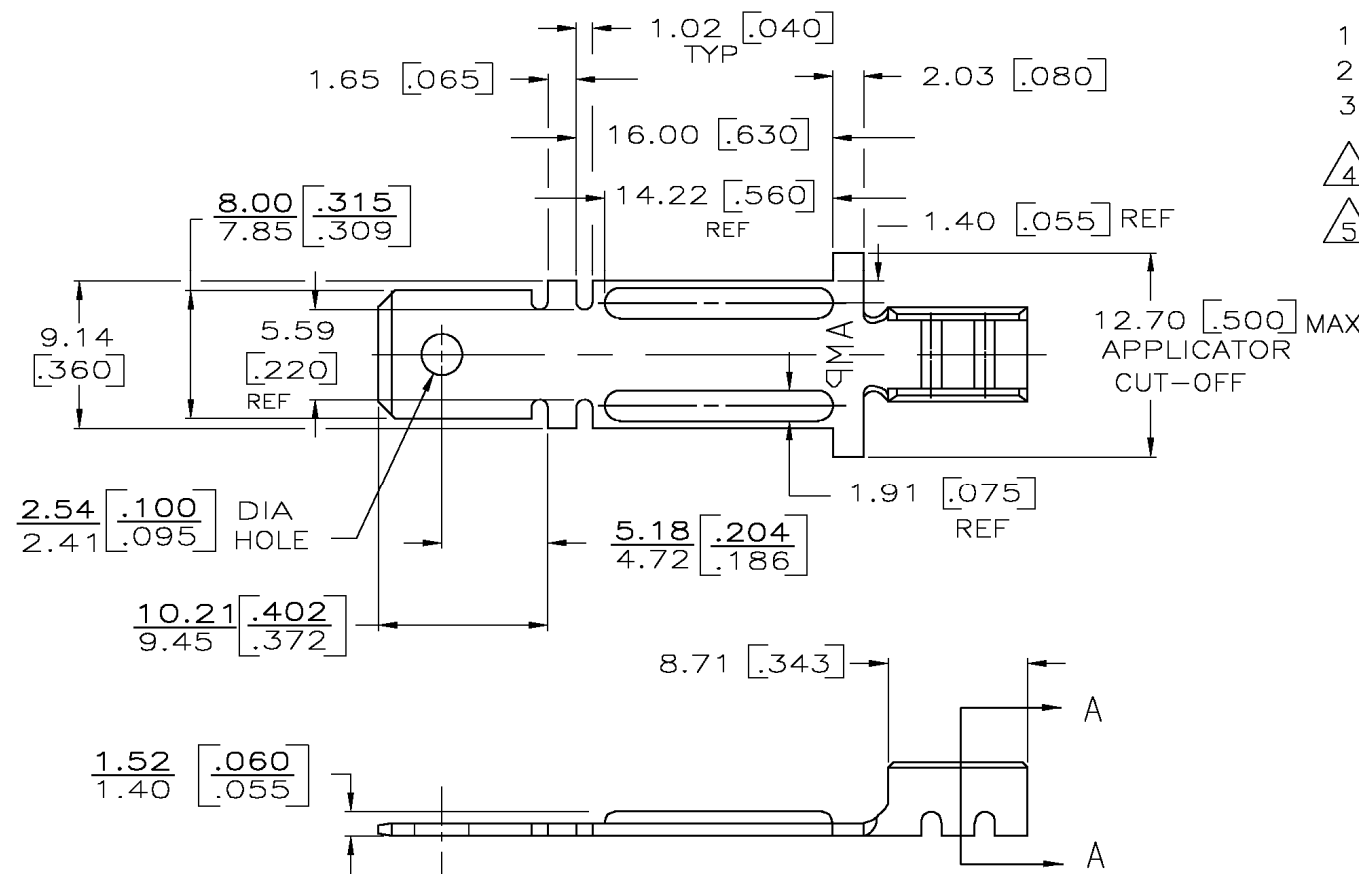

- 1 DIMENSIONS IN BRACKETS ARE IN INCHES.
- 2 CONTINUOUS STRIP ON REELS.
- 3 SEE SHEET 2 FOR SUGGESTED LOCKING IN CERAMIC.
- 4 REVERSE REELING OF 63300-1.
- 5 PRELIMINARY - NOT FOR PRODUCTION

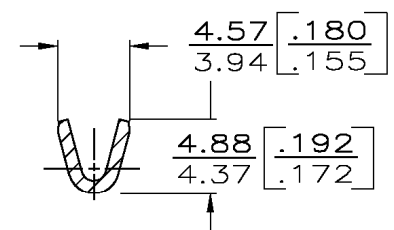

SECTION A-A

OBSOLETE

NICKEL	CR STEEL	[22 - 15] 0.30 - 1.45 MM DIA NI-CHROME	4	63300 - 4
TIN	H02 BRASS	[22 - 15] 0.30 - 1.45 MM DIA COPPER	5	63300 - 3
NICKEL	CR STEEL	[22 - 15] 0.30 - 1.45 MM DIA NI-CHROME		63300 - 2
NICKEL	CR STEEL	[22 - 15] 0.30 - 1.45 MM DIA NI-CHROME		63300 - 1
FINISH	MATERIAL	WIRE SIZE	PART NO.	
THIS DRAWING IS A CONTROLLED DOCUMENT.		DWN JR RUTH 5/9/86	Tyco Electronics Corporation Harrisburg, Pa 17105-3608	
DIMENSIONS: MM [INCHES]		CHK G YETTER 5/20/86		
TOLERANCES UNLESS OTHERWISE SPECIFIED:		APVD R KUZO 5/20/86	NAME	
0 PLC ± -		PRODUCT SPEC	TAB, FASTON, .312 SERIES	
1 PLC ± -		APPLICATION SPEC	-	
2 PLC ± -		114-2097	SIZE	RESTRICTED TO
3 PLC ± 0.25[.010]		WEIGHT -	A3 00779	C=63300
4 PLC ± -		CUSTOMER DRAWING	CAGE CODE	DRAWING NO
ANGLES ± -		SCALE 3:1	SHEET 1 OF 2	REV J1
SEE TABLE	SEE TABLE			

THIS DRAWING IS UNPUBLISHED. RELEASED FOR PUBLICATION
 BY TYCO ELECTRONICS CORPORATION. ALL RIGHTS RESERVED.

LOC	DIST	REVISIONS			
P	LTR	DESCRIPTION	DATE	DWN	APVD
AF	50	SEE SHEET 1			

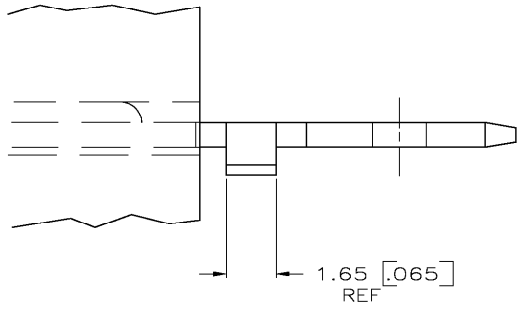
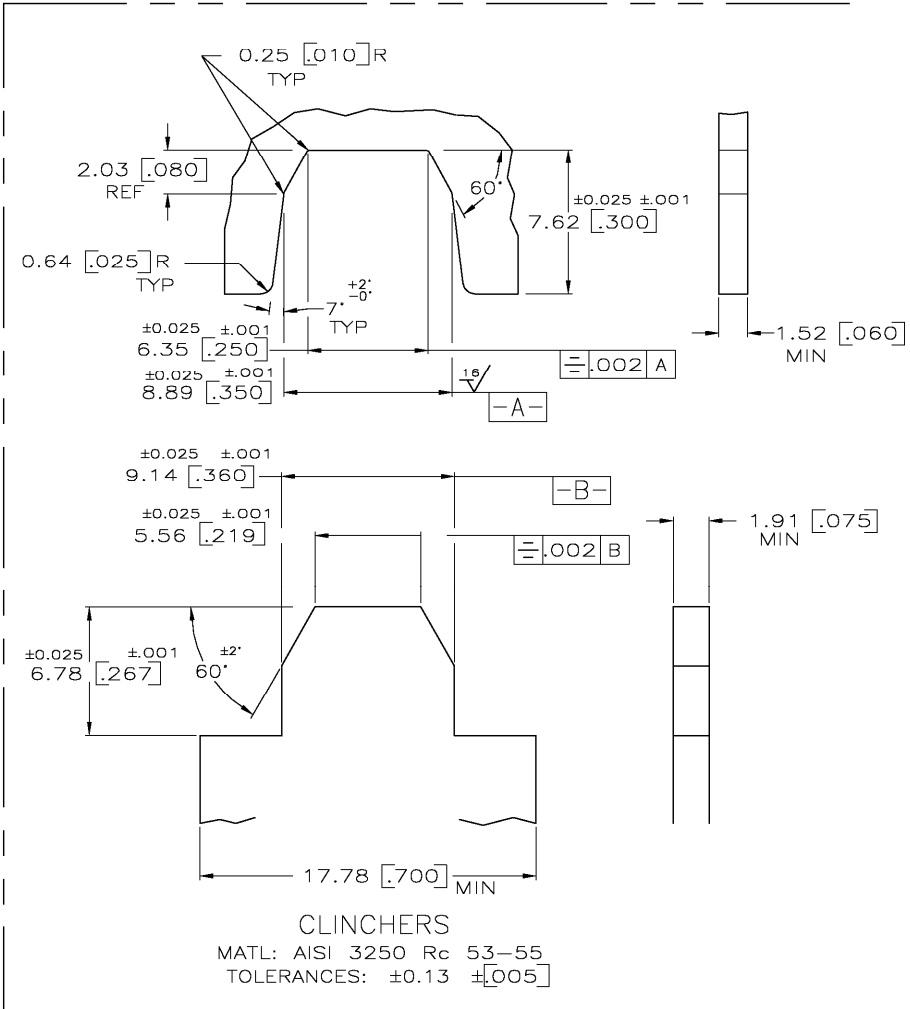
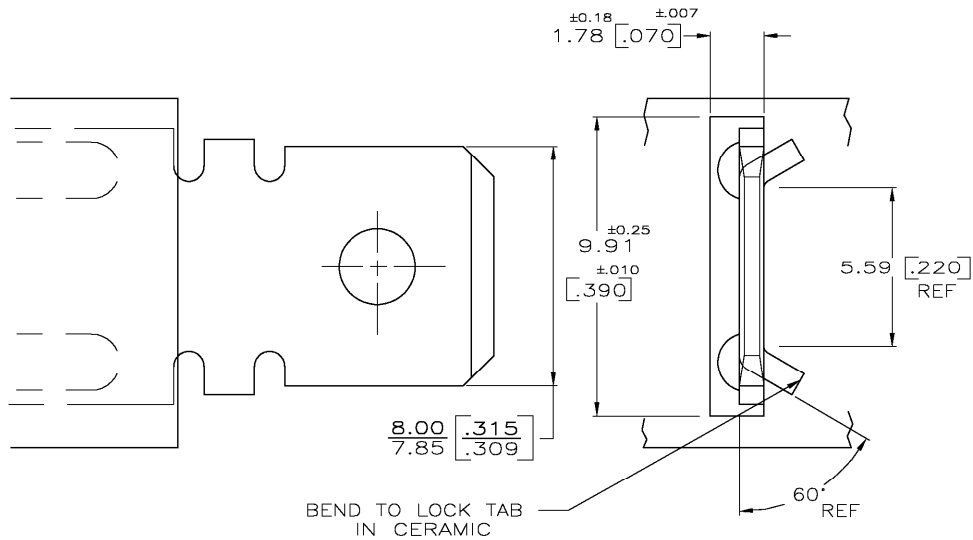

4	63300-4
5	63300-3
OBSOLETE	
	63300-2
	63300-1
	PART NO.

THIS DRAWING IS A CONTROLLED DOCUMENT.		DWN	JR RUTH	5/12/86	 Tyco Electronics Corporation Harrisburg, Pa 17105-3608
DIMENSIONS:		CHK	G YETTER	5/20/86	
MM [INCHES]		APVD	R KUZO	5/20/86	NAME
TOLERANCES UNLESS OTHERWISE SPECIFIED:		PRODUCT SPEC		TAB, FASTON, .312 SERIES	
0 PLC	±	APPLICATION SPEC		SIZE	CAGE CODE
1 PLC	±	114-2097		A2	00779
2 PLC	±	WEIGHT		DRAWING NO	
3 PLC	± 0.38 [015]	CUSTOMER DRAWING		C=63300	
4 PLC	±	SCALE		RESTRICTED TO	
ANGLES	±	8:1		-	
FINISH	SEE SHEET 1	SHEET		OF 2	
MATERIAL	SEE SHEET 1	REV		J1	