

- ① HOUSING MATERIAL: LIQUID CRYSTAL POLYMER PER ASTM D5138 LCP000 G30A 32250.
- ② CONTACT MATERIAL: PHOSPHOR BRONZE PER UNS ALLOY NO. C51100, TEMPER: H04.
- ③ CONTACT FINISH:(D)
 UNDERPLATE (ENTIRE CONTACT):
 0.00127 MIN NICKEL PER SAE-AMS-QQ-N-290
 ON MATING SURFACES:
 FLASH GOLD PER ASTM B 488, OVER
 0.00076 MIN PALLADIUM-NICKEL OVER UNDERPLATE, OR
 0.00076 MIN GOLD PER ASTM B 488 OVER UNDERPLATE.
 ON LEADS:
 0.00127 MIN MATTE TIN PER ASTM B 545 OVER UNDERPLATE.
 LUBRICATION (MIN MATING SURFACES):
 SURFACE CONDITIONER AFTER PLATING.
- ④ PART MARKING, LOCATED APPROXIMATELY AS SHOWN.

ROW	D	AA	AA
	C	AA	AA
	B	AA	AA
	A	AA	AA
		1	2
		POSITION	

P/N 5536603-1

ROW	D	AA	AA
	C	AB	AB
	B	AC	AC
	A	AC	AC
		1	2
		POSITION	

P/N 5536603-2

ROW	D	AB	AB
	C	AC	AC
	B	AC	AC
	A	AC	AC
		1	2
		POSITION	

P/N 5536603-6

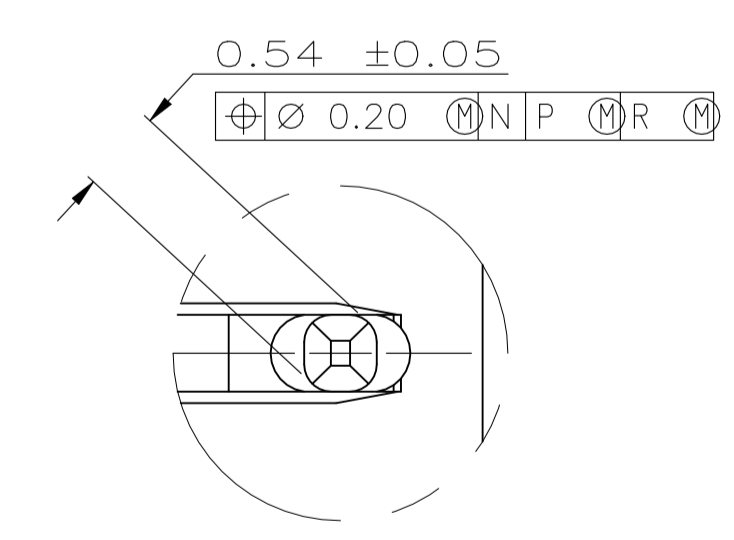

DETAIL Z
SCALE 20:1

CODE LETTER	MATING POST LENGTH D	LEAD LENGTH (REF)
AA	6.5	4.25
AB	7.25	4.25
AC	8	4.25

RECOMMENDED CIRCUIT PATTERN
 PER IPC-D300 TYPE II, CLASS C
 (COMPONENT SIDE)

6.00	1	4.25	10.00	5	11.83	③	③	8	5536603-6
6.00	1	4.25	10.00	5	11.83	③	③	8	5536603-2
6.00	1	4.25	10.00	5	11.83	③	③	8	5536603-1
G	F	E	C	B	A	FINISH	NO OF POSN	PART NUMBER	

THIS DRAWING IS A CONTROLLED DOCUMENT.

DIMENSIONS: INCHES	TOLERANCES UNLESS OTHERWISE SPECIFIED:	DIN 11.00 ± .00	10/19/92		Tyco Electronics Corporation Harrisburg, Pa 17105-3608
0. PLC ± -	1. PLC ± -	2. PLC ± 0.13	02/18/93		
MATERIAL		FINISH	NAME	PRODUCT SPEC: 108-1441 APPLICATION SPEC: 114-1075 SIZE: A1 CAGE CODE: 00779 DRAWING NO: 5536603 RESTRICTED TO: - CUSTOMER DRAWING	

SCALE 4:1 SHEET 1 of 1 REV A