

WIRE		TERMINAL COLOR CODE	DIE SET	
SIZE (AWG)	INSULATION DIAMETER (Max.)		PART NO.	COLOR CODE
8	7.57 [.298]	Red	48858-1	Red Dot
6	9.58 [.377]	Blue	48859-1	Blue Dot
4	11.10 [.436]	Yellow	48860-1	Yellow Dot
2	12.82 [.505]	Red	48861-1	Red Dot

Figure 1

1. INTRODUCTION

This instruction sheet provides information on product application and a maintenance and inspection procedure for the crimping dies listed in Figure 1. The dies are used in Hydraulic Crimping Heads 58422-1, 69066, 1752877-1, and 1752787-1. For detailed information on the hydraulic power unit and hydraulic crimping head, refer to the instructions packaged with these tools.

These dies are designed to crimp AMPLI-BOND and PLASTI-GRIP terminals on wire sizes 8 AWG to 2 AWG. Dies are coated with a preservative to prevent rust and corrosion. Wipe preservative from dies, particularly from crimping areas.

NOTE All dimensions in this document are in millimeters [with inches in brackets]. Figures and illustrations are for reference only and are not drawn to scale.

Reasons for reissue are provided in Section 6, REVISION SUMMARY.

2. DIE INSTALLATION AND REMOVAL

DANGER Avoid personal injury. Exercise caution to avoid accidentally depressing foot pedals or trigger control of hydraulic power unit when installing or removing dies.

2.1. Die Installation

1. Refer to the chart in Figure 1 and verify that you have the proper die set for the terminal and wire size being used.

2. Remove latch pin on head, then open yoke. See Figure 2.
3. Loosen set screw in yoke.
4. Insert stationary die into well of yoke as shown in Figure 2. Tighten set screw.
5. Activate power unit to advance ram until set screw is visible.

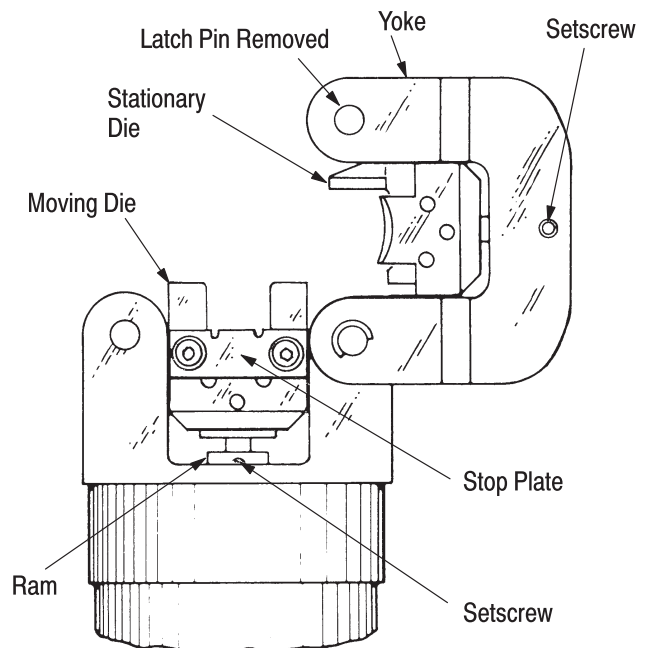

Figure 2

6. Loosen set screw in ram and insert moving die into ram well as shown in Figure 2. Tighten set screw.



NOTE Moving die must be properly oriented to mate with stationary die.

7. Activate power unit to allow ram to return to the “down” position.

2.2. Die Removal

1. Remove latch pin and open yoke.
2. Loosen set screw in yoke and remove stationary die.
3. Raise ram to “full up” position. Loosen set screw and remove moving die.

3. OPERATION

3.1. Wire Stripping and Crimping Procedure



DANGER Avoid personal injury. When operating power unit, exercise caution while holding terminals or wire near crimping area. Never place anything in the dies except terminals.

1. Strip wire to dimensions listed in Figure 3. Do NOT nick or cut conductor strands.
2. Insert stripped wire in terminal. End of wire must be flush with or extend beyond edge of terminal wire barrel.

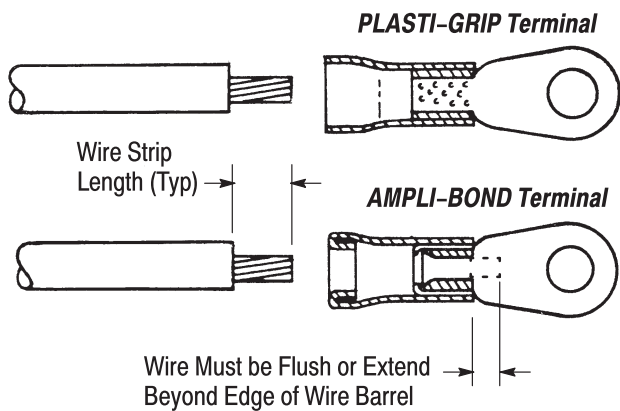

WIRE SIZE (AWG)	WIRE STRIP LENGTH			
	AMPLI-BOND		PLASTI-GRIP	
	MINIMUM	MAXIMUM	MINIMUM	MAXIMUM
8	11.51 [.453]	12.29 [.484]	11.51 [.453]	12.29 [.484]
6			15.47 [.609]	16.26 [.640]
4			15.47 [.609]	16.26 [.640]
2			11.51 [.453]	12.29 [.484]

Figure 3

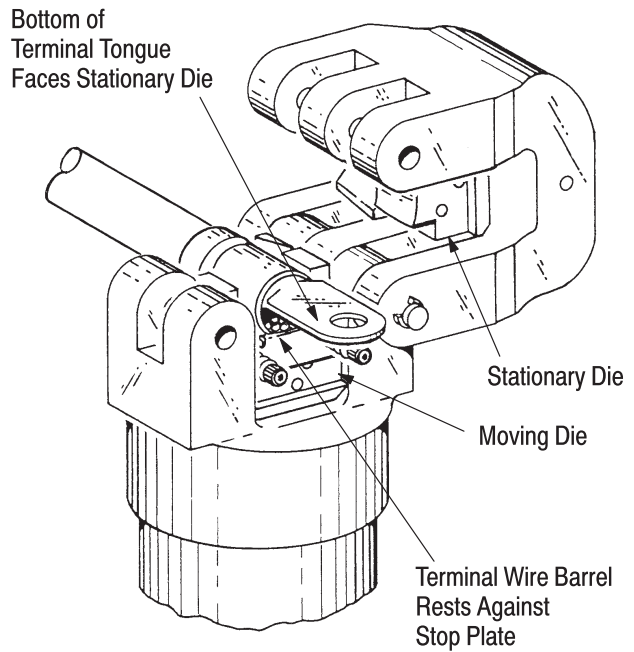

Figure 4

3. With yoke open, place terminal on dies. See Figure 4.
4. Bottom of terminal tongue should face stationary die and terminal wire barrel should rest against stop plate as shown in Figure 4.
5. Close yoke and insert latch pin.



DANGER Ensure that latch pin is fully inserted or damage may occur to yoke, dies, or latch pin.

6. Hold terminal in place and activate power unit to complete crimp. Open yoke and remove crimped terminal.



NOTE If terminal sticks in die after crimping, apply a rocking action to remove it from die.

3.2. Insulation Crimp Adjustment

This adjustment is made to both stationary and moving dies after they have been placed in crimping head.

1. The dies have three insulation crimp positions. The adjustment is made by moving a pin-key (see Figure 5). When the pin-key is pushed all the way in, the insulation crimping section of the die is in the loose position; when the pin-key is halfway out, the insulation crimping section of the die is in the medium position; when the pin-key is all the way out, the insulation crimping section of the die is in the tight position.

2. To adjust the insulation crimp, loosen socket head cap screws and push pin-key all the way in so that insulation crimp section of the die is in the loose position.

3. Press and hold insulation die down against the pin-key. This will prevent the spring-loaded pin-key from popping back.

4. Tighten socket head cap screws.

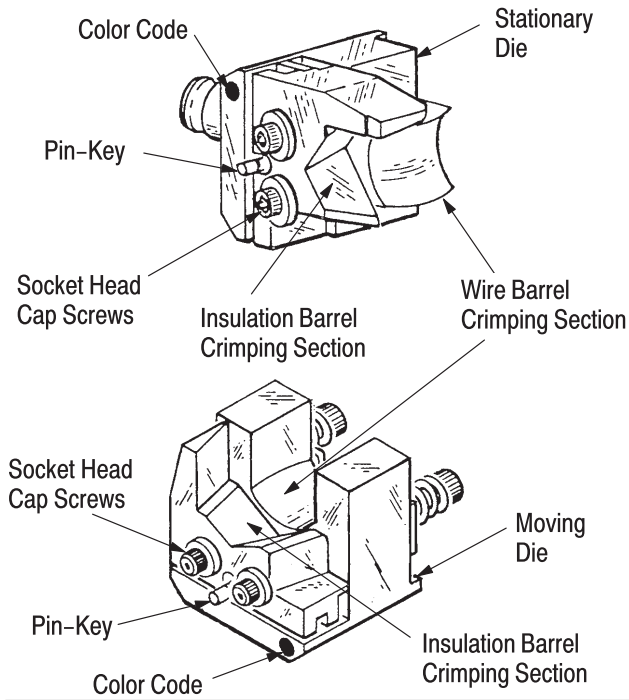

Figure 5

NOTE



Make certain insulation crimping sections of moving and stationary dies are both adjusted to the same position.

NOTE



AMPLI-BOND terminals provide a "grip" on wire insulation. PLASTI-GRIP terminals provide only a "support" for the wire.

5. Perform a test crimp (refer to Paragraph 3.1).

6. Remove crimped terminal from dies and visually inspect the insulation crimp portion of terminal. The insulation crimp should "grip" wire insulation (when using AMPLI-BOND terminals) or provide "support" for wire insulation (when using PLASTI-GRIP terminals).

7. If the insulation crimp does not grip or support wire insulation as described in step 6, loosen socket head cap screws and set the pin-keys in the medium position. Then follow Steps 3 and 4.

8. Make another test crimp over previously crimped terminal.

Accept

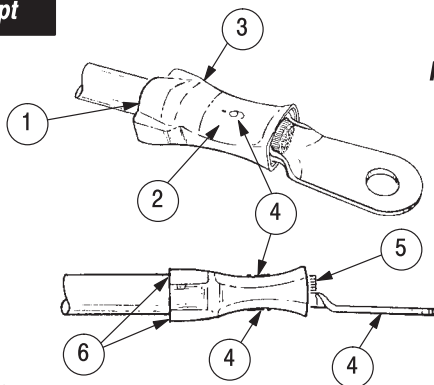

- ① Wire fully inserted.
- ② Crimp centered on wire barrel.
- ③ Correct color code and die combination. (Terminal insulation color matches color dots on dies.)
- ④ Wire size being used is same as wire size embossed on terminal insulation and stamped on terminal tongue.
- ⑤ End of conductor is flush with or extends beyond end of wire barrel of terminal.
- ⑥ Insulation barrel is in contact with wire insulation. (AMPLI-BOND terminals have insulation "grip" and PLASTI-GRIP terminals have insulation "support".)

Crimp Inspection of AMPLI-BOND and PLASTI-GRIP Terminals

Reject

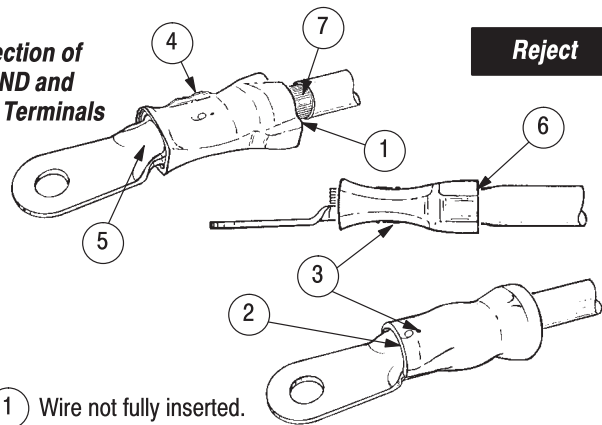

- ① Wire not fully inserted.
- ② Crimp not centered on wire barrel. (Terminal was not butted against stop plate. See Figure 4.)
- ③ Wrong die and terminal color code combination. See Figure 1.
- ④ Excessive flash or extruded insulation. (Wrong size or damaged dies.)
- ⑤ End of conductor is not flush with or extending beyond end of wire barrel of terminal.
- ⑥ Wire insulation pinched. (Insulation crimp too tight on AMPLI-BOND terminals.)
- ⑦ Nicked or missing conductor strands.

Figure 6

9. Remove crimped terminal from dies and visually inspect insulation crimp.
10. Repeat adjustment as necessary until desired insulation crimp is obtained. Do NOT use a tighter setting than required.
11. Refer to Paragraph 3.4 and Figure 6 for crimp inspection procedure.

3.3. Color Code

Terminals and dies are color coded as listed in Figure 1 and shown in Figure 5. The dies have the terminal size stamped in the wire barrel crimp sections of both the moving and stationary dies. When crimped, the wire size will appear on both sides of the terminal wire barrel. The wire size appearing on the crimped wire barrel should always agree with the wire size stamped on the terminal tongue.

3.4. Crimp Inspection

Inspect crimped terminals by checking the features described in Figure 6.

NOTE



AMPLI-BOND terminals are shown in Figure 6. Inspection procedure is the same for PLASTI-GRIP terminals.

Use only the terminals that meet the conditions shown in the "ACCEPT" column. "REJECT" terminals can be avoided through careful use of instructions in Paragraphs 3.1 and 3.2, and by performing regular die maintenance described in Section 4.

4. MAINTENANCE/INSPECTION

Regular inspections should be performed by quality control personnel. A record of scheduled inspections should remain with the dies and/or be supplied to the supervisory personnel responsible for the dies. Though recommendations call for at least one inspection a month, the inspection frequency should be based on the amount of use, ambient working conditions, operator training and skill, and established company standards. These inspections should be performed in the following sequence:

4.1. Cleaning

Do not allow deposits of dirt, grease, or foreign matter to accumulate in the die closure area, or on the bottoming surfaces of the dies. These deposits may prevent the dies from bottoming fully and may also cause excessive wear in the die closure surfaces, thereby affecting the quality of the crimp. The dies should be wiped clean frequently with a clean cloth.

4.2. Visual Inspection

Visually inspect the die closure surfaces for flattened, broken, pitted, or chipped conditions. Although dies

may gage within permissible limits, worn or damaged die closure surfaces can affect the quality of the crimp. Examples of possible damaged die surfaces are shown in Figure 7.

4.3. Plug Gage Inspection

Every die set is inspected and tested for proper die closure dimensions before packaging. An inspection should be performed periodically to check the die closure for excessive wear.

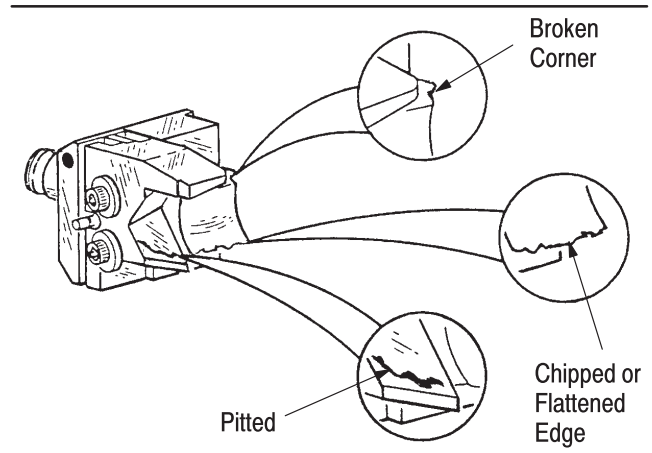
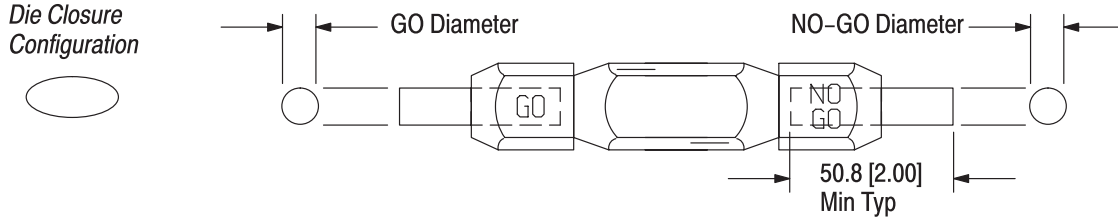

Figure 7

The die closure inspection is accomplished using plug gages. A suggested gage design and the GO and NO-GO dimensions of the plug gage elements are shown in Figures 8 and 9. The following procedure is recommended for inspecting the die closures.

1. Clean oil or dirt from the bottoming surfaces, die closure surfaces, and plug gage elements.
2. Remove two socket head cap screws and stop plate from moving die. See Figure 10, Detail A. This will provide access to the wire barrel dies for plug gaging.
3. Assemble stationary and moving dies so that wire barrel dies are bottomed, but not under pressure. See Figure 10.
4. With wire barrel dies bottomed, inspect the wire barrel crimp die closure using the proper plug gage. Hold gage in straight alignment with the die closure and carefully try to insert, without forcing, the GO element. See Figure 10, Detail A. The GO element must pass completely through the wire barrel crimp die closure.
5. Try to insert the NO-GO element. The NO-GO element may enter partially, but must not pass completely through the wire barrel die closure.
6. Re-install stop plate and secure with the two socket head cap screws.

SUGGESTED PLUG GAGE DESIGN - WIRE BARREL CRIMP



TOOL NUMBER	GAGE ELEMENT DIAMETER	
	GO	NO-GO
48858-1	5.105-5.113 [.2010-.2013]	5.255-5.258 [.2069-.2070]
48859-1	6.020-6.027 [.2370-.2373]	6.170-6.172 [.2429-.2430]
48860-1	6.833-6.840 [.2690-.2693]	6.982-6.985 [.2749-.2750]
48861-1	8.103-8.110 [.3190-.3193]	8.252-8.255 [.3249-.3250]

Figure 8

SUGGESTED PLUG GAGE DESIGN - INSULATION BARREL CRIMP

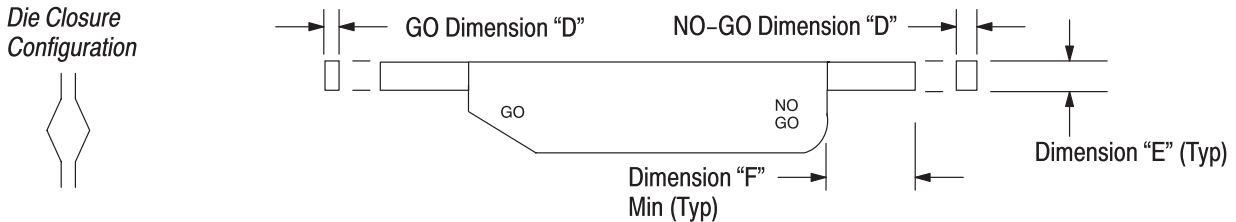

TOOL NUMBER	GAGE ELEMENT DIMENSION "D"		DIMENSION "E"	DIMENSION "F"
	GO	NO-GO		
48858-1	3.861-3.868 [.1520-.1523]	4.366-4.369 [.1719-.1720]	7.14 [.281]	4.83 [.190]
48859-1	4.216-4.224 [.1660-.1663]	4.722-4.724 [.1859-.1860]	7.87 [.310]	
48860-1	4.115-4.122 [.1620-.1623]	4.620-4.623 [.1819-.1820]	8.13 [.320]	
48861-1	4.623-4.630 [.1820-.1823]	5.128-5.131 [.2019-.2020]	10.29 [.405]	6.35 [.250]

Figure 9

7. Loosen socket head cap screws from both stationary and moving insulation dies and move pin-keys all the way out so that insulation crimping sections of dies are in the tight position. See Figure 10, Detail B.

8. Press and hold insulation die down against pin-key, and tighten the socket head cap screws.

9. With wire barrel dies bottomed, inspect the insulation crimp die closure using the proper plug gage in the same manner as steps 3 through 5. See Figure 10, Detail B.

10. If both wire barrel and insulation die closures meet the plug gage conditions, the dies are considered to be dimensionally correct.

and controlled to prevent lost time when replacement of parts is necessary. Order replacement parts through your Tyco Electronics Representative, or call 1-800-526-5142, or send a facsimile of your purchase order to 1-717-986-7605, or write to:

CUSTOMER SERVICE (38-35)
 TYCO ELECTRONICS CORPORATION
 P.O. BOX 3608
 HARRISBURG, PA 17105-3608

Dies may be returned for evaluation and repair. For die repair service, contact a representative at 1-800-526-5136.

5. REPLACEMENT AND REPAIR

The parts listed in Figure 11 are customer-replaceable. A complete inventory can be stocked

6. REVISION SUMMARY

- Updated document to corporate requirements
- New format

Detail A
Inspection of
Wire Barrel
Crimping Dies

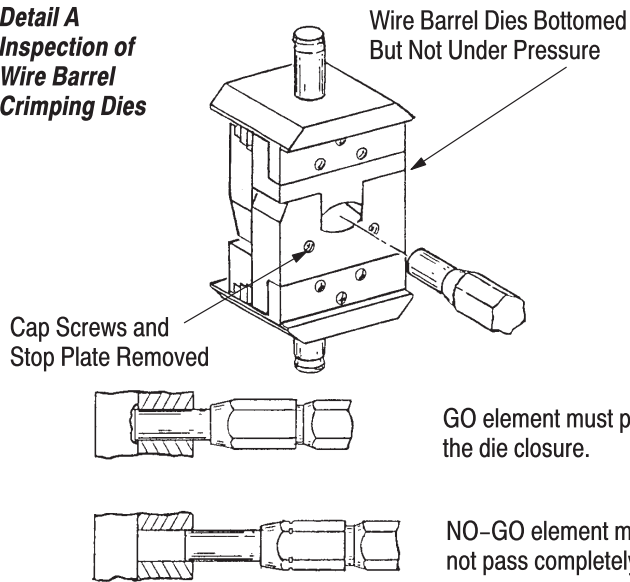

Detail B
Inspection of
Insulation Barrel
Crimping Dies

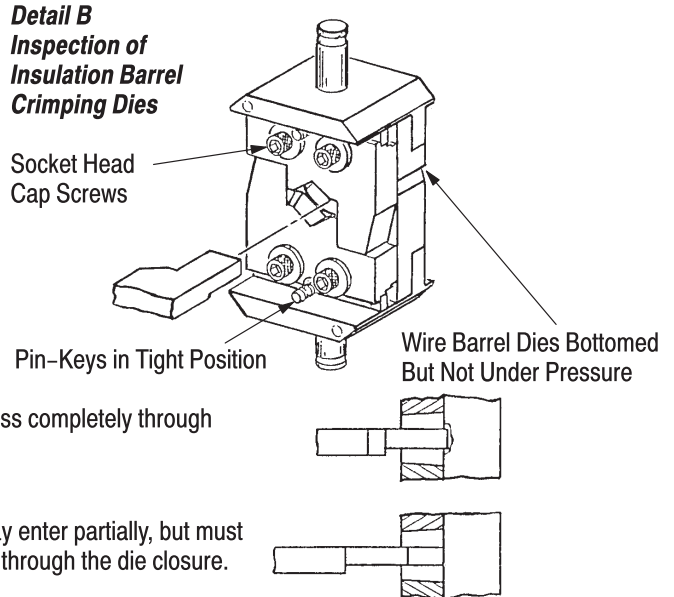
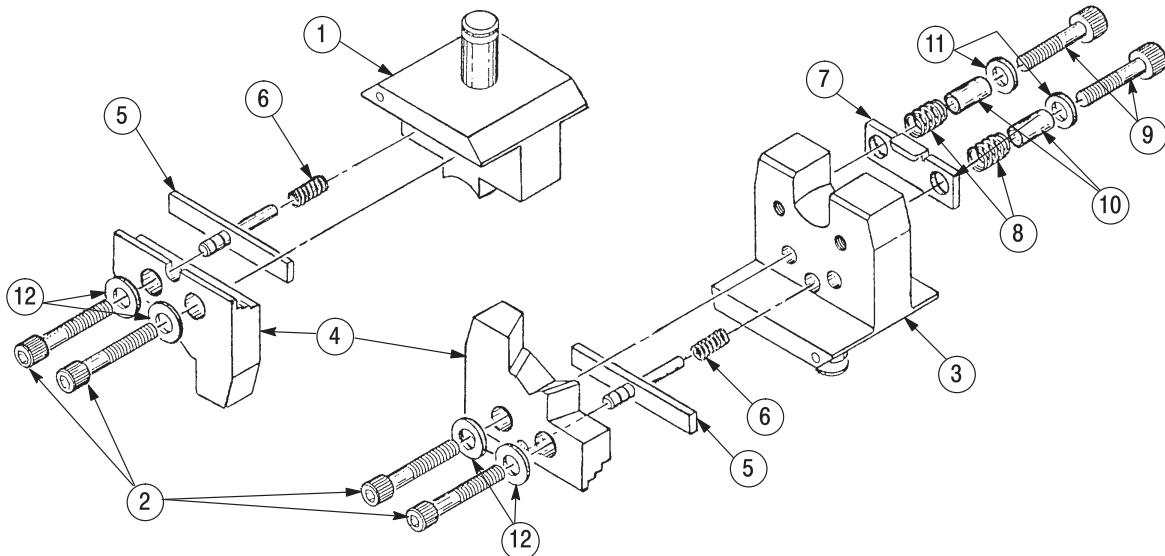

Figure 10



ITEM	DESCRIPTION	QTY PER DIE SET	DIE SET NUMBERS AND COMPONENT PART NUMBERS			
			48858-1	48859-1	48860-1	48861-1
1	Stationary Die	1	307809-1	307809-2	307809-3	307809-4
2	Screw	4	1-23030-3	1-23030-3	1-23030-3	1-23030-3
3	Moving Die	1	307810-1	307810-2	307810-3	307810-4
4	Insert, Insulation	2	45873-4	45873-1	45873-2	45873-4
5	Key Assembly, Adjustable	2	313291-5	313291-4	313291-3	313291-3
6	Spring	2	1-22279-9	1-22279-9	1-22279-9	1-22279-9
7	Stop Plate	1	307130-1	307130-1	307130-2	307130-3
8	Spring	2	6-59683-8	6-59683-8	6-59683-8	6-59683-8
9	Screw	2	2-21000-8	2-21000-8	2-21000-8	2-21000-8
10	Sleeve	2	306363	306363	306363	306363
11	Washer	2	21055-6	21055-6	21055-6	21055-6
12	Washer	4	306098-2	306098-2	306098-2	306098-2

Figure 11