

THIS DRAWING IS UNPUBLISHED
 RELEASED FOR PUBLICATION 2012
 © COPYRIGHT 2012 By TE Connectivity ALL RIGHTS RESERVED.

LOC		DIST		REVISIONS			
P	LTR	DESCRIPTION	DATE	DWN	APVD		
A		NEW DRAWING	14MAR2012	VP	I.B		
B		The Hole dimension change to 12mm	30MAY2012	VP	I.B		

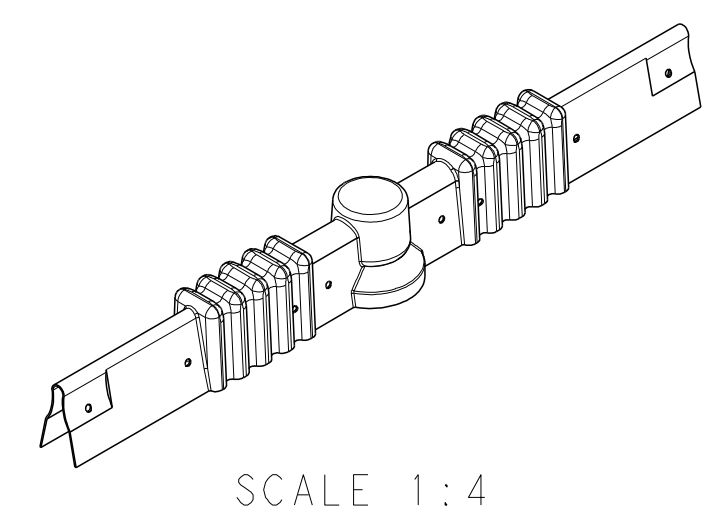
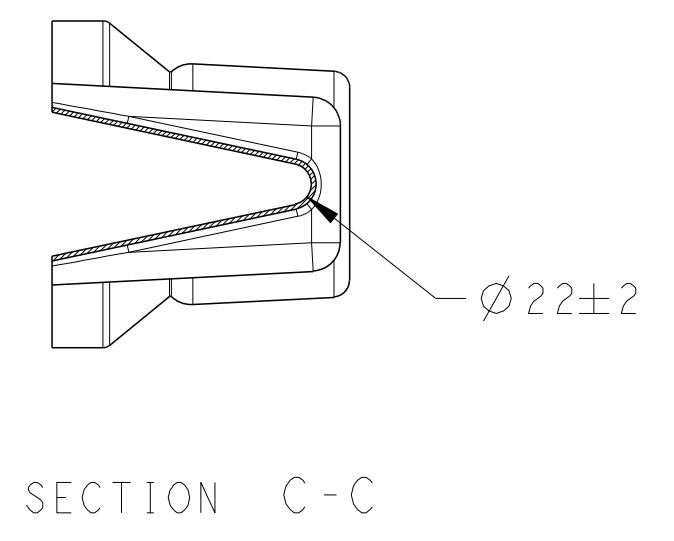
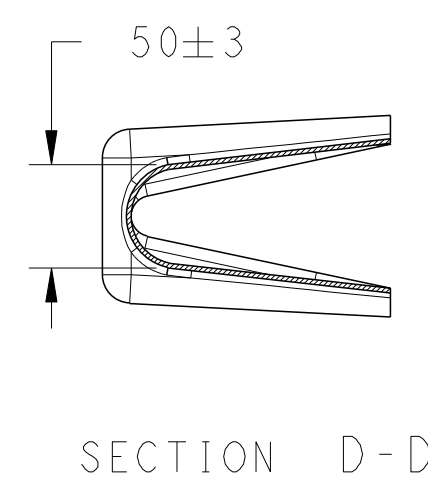
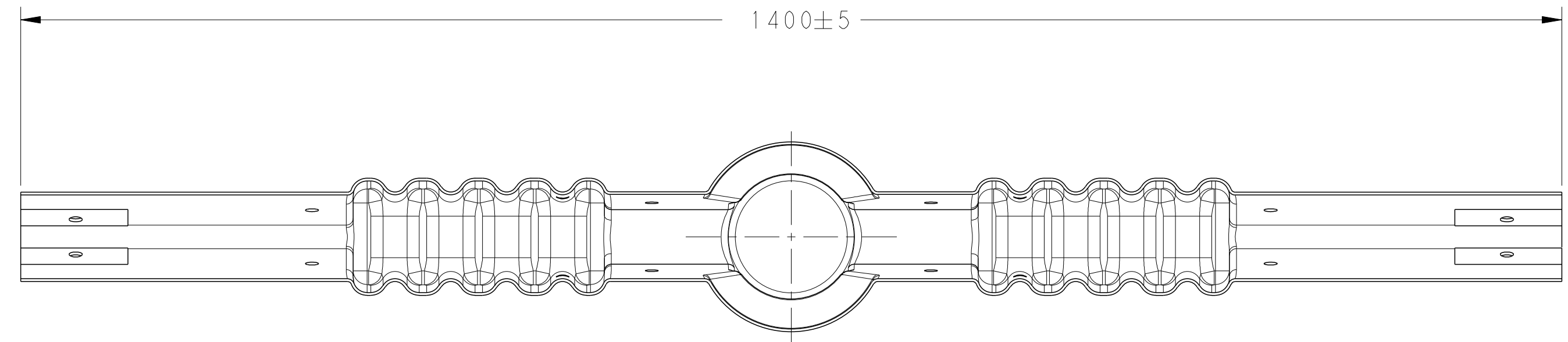
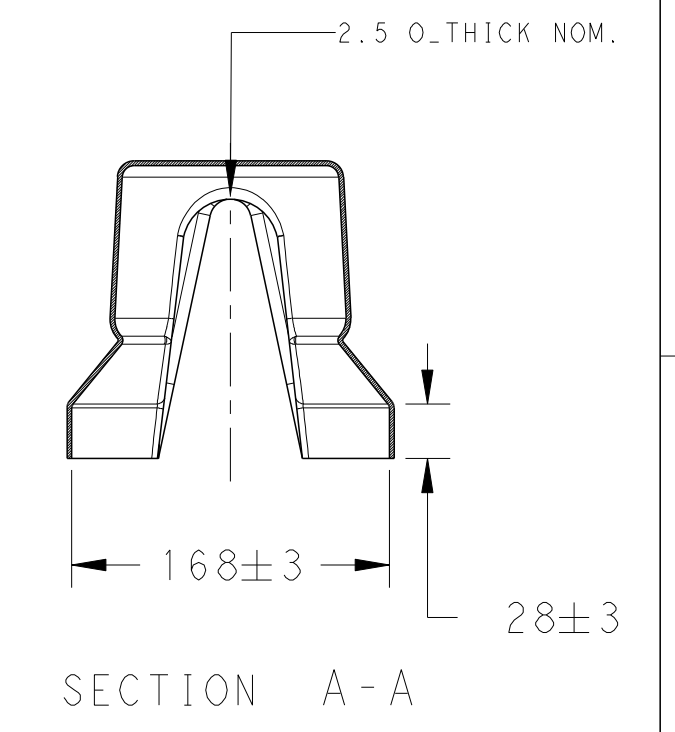
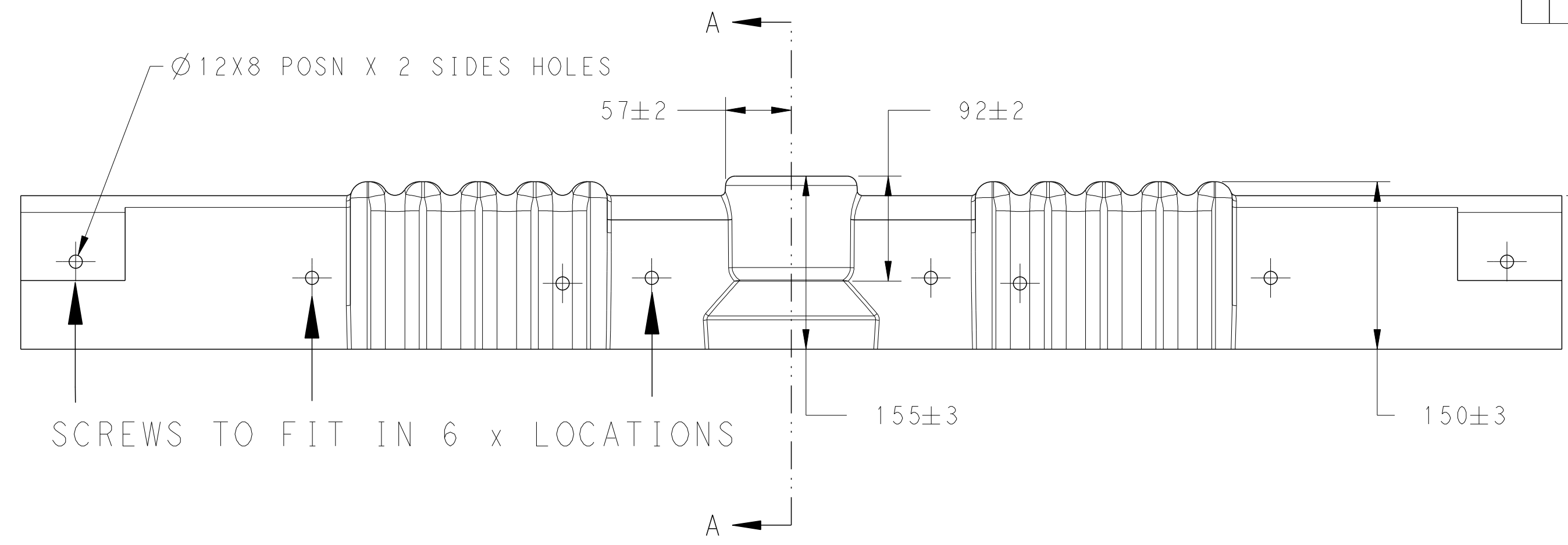

THIS DRAWING IS A CONTROLLED DOCUMENT.		DWN Vishnu 13APR2012	STE TE Connectivity	
DIMENSIONS: mm		CHK I_Bond 13APR2012		
TOLERANCES UNLESS OTHERWISE SPECIFIED:		APVD I_Bond 13APR2012	NAME BC1C-1217-TR-DE02-(B3)	
Ø PLC ± 1 PLC ± 2 PLC ± 3 PLC ± 4 PLC ± ANGLES ±1° FINISH		PRODUCT SPEC -	SIZE CAGE CODE DRAWING NO RESTRICTED TO	
MATERIAL -		APPLICATION SPEC -	A200779 C-4-1899726-5	
		WEIGHT -	SCALE 1:4 SHEET 1 OF 2 REV B	
		CUSTOMER DRAWING		

THIS DRAWING IS UNPUBLISHED
 RELEASED FOR PUBLICATION 2012
 © COPYRIGHT 2012 By TE Connectivity ALL RIGHTS RESERVED.

LOC	DIST	REVISIONS			
P	LTR	DESCRIPTION	DATE	DWN	APVD
AI	-	SEE SHEET 1	-	-	-

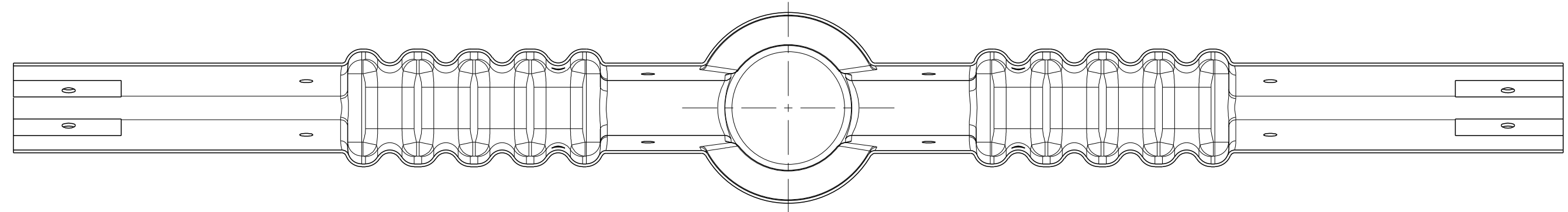
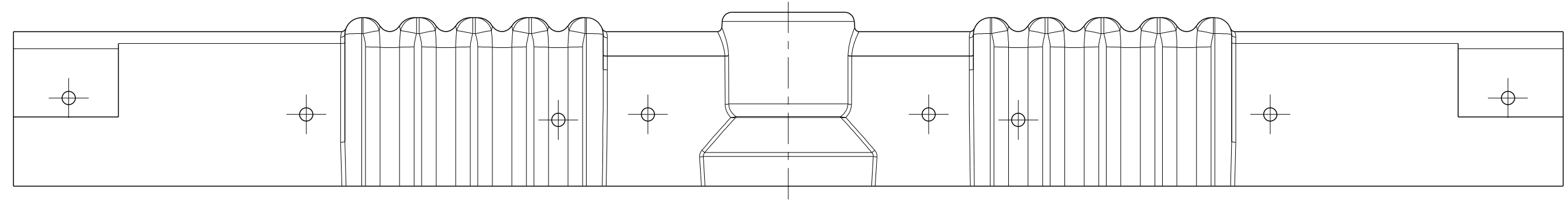
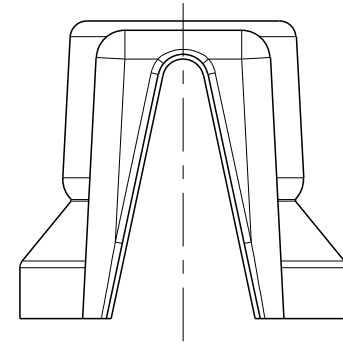

1. MATERIAL : CLEAR PET-
2. MIN WALL THICKNESS 1.5 mm
3. TOLERANCE +/- 3mm UNLESS OTHERWISE STATED.
4. COLD MARKS ALLOWABLE SO LONG AS WALL THICKNESS MAINTAINED.
5. PART TO BE SHIPPED CLEAN AND FREE OF DUST AND DEBRIS.
6. EACH PART TO BE EMBOSSSED WITH "TE CONNECTIVITY" , "DATE" , PART NO" AND "RECYCLE CYMBOL".
MIN 6mm HIGH.
7. EACH BOX TO BE LABELLED WITH DESCRIPTION, BATCH NO, PART NO
MANUFACTURE DATE AND QUALITY.
8. EACH BOX TO INCLUDE 6pcs x 3 BAGS OF SCREWS.
9. EACH BOX TO INCLUDE 1x INSTALLATION INSTRUCTION
10. EACH BOX TO INCLUDE 3x CLEAR BIRDCAPS

THIS DRAWING IS A CONTROLLED DOCUMENT.		DWN Vishnu 13APR2012	TE TE Connectivity	
DIMENSIONS: mm		CHK I_Bond 13APR2012		
TOLERANCES UNLESS OTHERWISE SPECIFIED:		APVD I_Bond 13APR2012	NAME BC1C-1217-TR-DE02-(B3)	
 PLC ± 1 PLC ± 2 PLC ± 3 PLC ± PLC ± ANGLES ±1° FINISH		PRODUCT SPEC -	RESTRICTED TO -	
MATERIAL -		APPLICATION SPEC -	SIZE A200779	CAGE CODE C-4-1899726-5
		WEIGHT -	DRAWING NO C-4-1899726-5	
		CUSTOMER DRAWING	SCALE 1:4	SHEET 2 OF 2 REV B