

REVISIONS

| P | LTR | DESCRIPTION   | DATE      | DWN | APVD |
|---|-----|---------------|-----------|-----|------|
|   | A   | ECN-24-266545 | 17MAY2024 | KS  | RB   |

EC No.

## Battery Disconnecter 2x200A

Page 1 of 1

Circuit

**Technical Data:**

|                                         |                                                   |
|-----------------------------------------|---------------------------------------------------|
| Case Material                           | PA GF black                                       |
| Switch Lever Material                   | PA GF red                                         |
| Min. Insulation Resistance              | 100MΩ                                             |
| Dielectric Withstanding Voltage         | 1050V-1min.                                       |
| Max. Contact Drop during Resistive Load | 150mV                                             |
| Voltage                                 | to 32VDC                                          |
| Duty Rating                             | 2x200A                                            |
| Overload                                | 2x500A-180sec.<br>2x1000A-30sec.<br>2x2500A-5sec. |
| Sealing                                 | IP 67/ IEC 529                                    |
| Vibration                               | 4G / 50-2000Hz                                    |
| Shock G-Level                           | 6G / 11ms                                         |
| Weight                                  | ~355g / 0.78 Pound                                |
| Temperature Range                       | -40°C to +85°C                                    |
| Wire Section (at nominal Load)          | min. 70mm <sup>2</sup>                            |
| Mounting Position                       | optional                                          |
| Switch Lever                            | removeable                                        |
| Switch Lever Spare Part No.             | 35-200-014                                        |
| Max. Torque (Main Contacts)             | 15-20Nm                                           |

| Date              | Name  | mm                 | Scale |
|-------------------|-------|--------------------|-------|
| Create 02.04.2019 | Seege | General Tolerances | 1:2   |
| Edited 11.06.2019 | Seege |                    |       |
| Check 24.06.2019  | Grind |                    |       |

Drawing No: 35-221-100-R

NSN:

For this drawing we reserve the copyright in accordance with DIN ISO 16016

NOTE  
Bemerkungen:

- 1 TE-CONNECTIVITY ORDER-NUMBER  
TE-Connectivity Bestellnummer
- 2 DO NOT SWITCH UNDER LOAD!  
Nicht unter Last schalten!

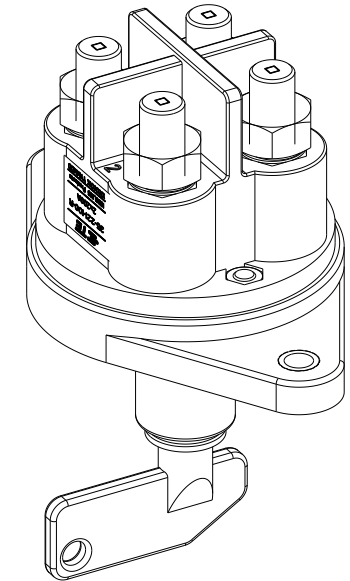

| 1            | K1130516 | A           | BATTERY DISCONNECTOR 2X200A<br>Batterietrennschalter 2X200A | 1 |
|--------------|----------|-------------|-------------------------------------------------------------|---|
| TE ORDER-NO. | REV.     | DESCRIPTION | ITEM NO                                                     |   |

|                                        |                                                                           |                                                                                                  |                    |
|----------------------------------------|---------------------------------------------------------------------------|--------------------------------------------------------------------------------------------------|--------------------|
| THIS DRAWING IS A CONTROLLED DOCUMENT. |                                                                           | DWN K.Seeger 02APR2019<br>CHK K.Seeger 11JUN2019<br>APVD U.Grindemann 24 JUN2019<br>PRODUCT SPEC |                    |
| DIMENSIONS:<br>mm                      | TOLERANCES UNLESS OTHERWISE SPECIFIED:<br>DIN ISO 2768 cL                 |                                                                                                  |                    |
|                                        | 0 PLC ±<br>1 PLC ±<br>2 PLC ±<br>3 PLC ±<br>4 PLC ±<br>ANGLES ±<br>FINISH | NAME<br><b>BATTERY DISCONNECTOR 2X200A</b><br>Batterietrennschalter 2X200A                       |                    |
| MATERIAL                               | WEIGHT                                                                    | SIZE A3<br>CAGE CODE 00779<br>DRAWING NO. 35-221-100-R                                           | RESTRICTED TO      |
| CUSTOMER DRAWING                       |                                                                           | SCALE                                                                                            | SHEET 1 OF 1 REV A |