

THIS DRAWING IS UNPUBLISHED. RELEASED FOR PUBLICATION
 © COPYRIGHT - By - ALL RIGHTS RESERVED.

LOC		DIST		REVISIONS			
P	LTR	DESCRIPTION		DATE	DWN	APVD	
G	14	D3		REVISED PER ECO-12-021425	11DEC12	KH DR	

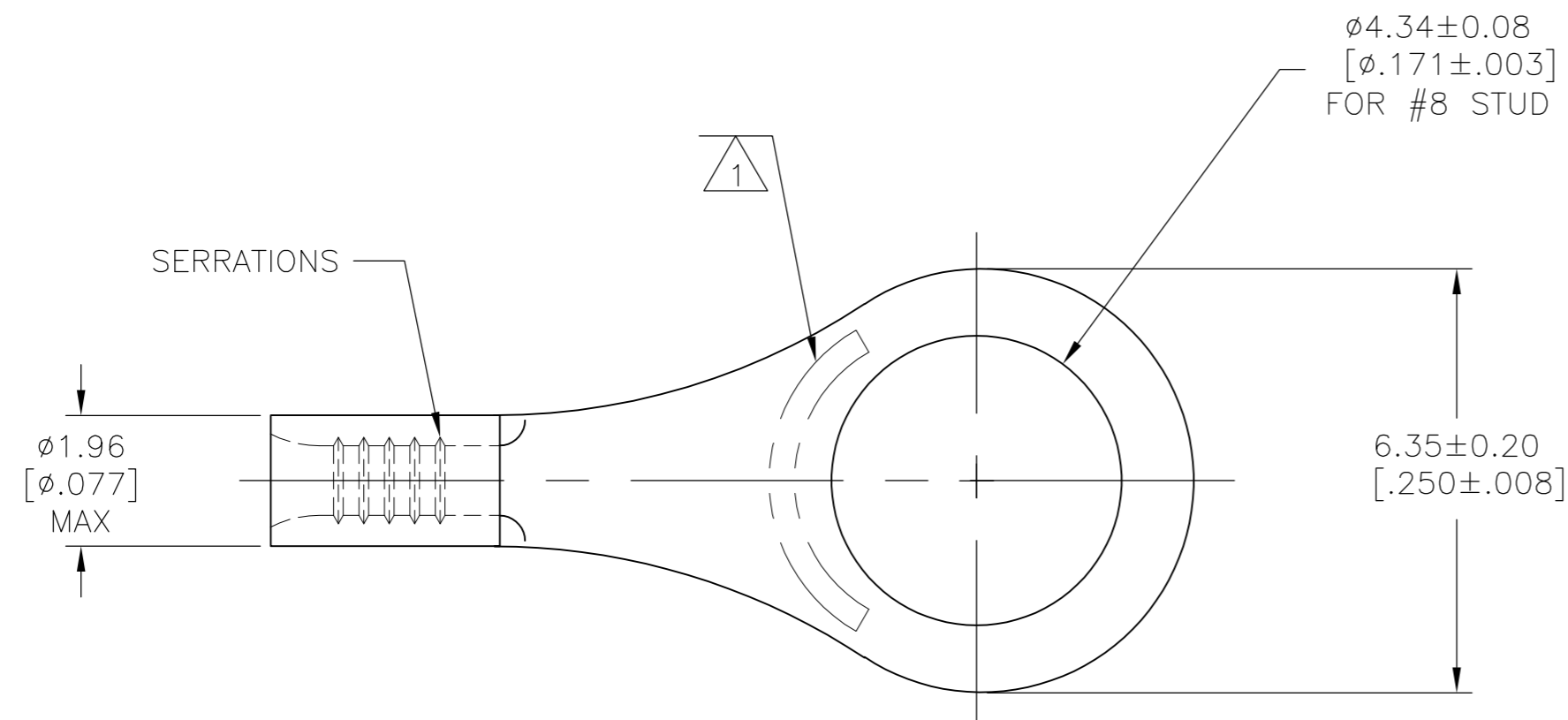

AMP WIRE RANGE	Listed FILE E13288	LR7189 Certified
26-22 AWG STRANDED	NOT LISTED	NOT LISTED

- 1 STAMP AMP APPROX AS SHOWN
- 2 0.00254 [.000100] MIN TIN PER ASTM B-545
- 3 CLEANED, UNPLATED
- 4 0.00254 [.000100] MIN EXT THK GOLD PL PER ASTM B-488 OVER 0.00076 [.000030] MIN NICKEL PER SAE AMS QQ-N-290.
- 5 COPPER PER ASTM B-152, ANNEALED
- 6 NOTE DELETED
- 7 0.0050 [.000200] MIN EXT THK NICKEL PLATE PER SAE AMS QQ-N-290.

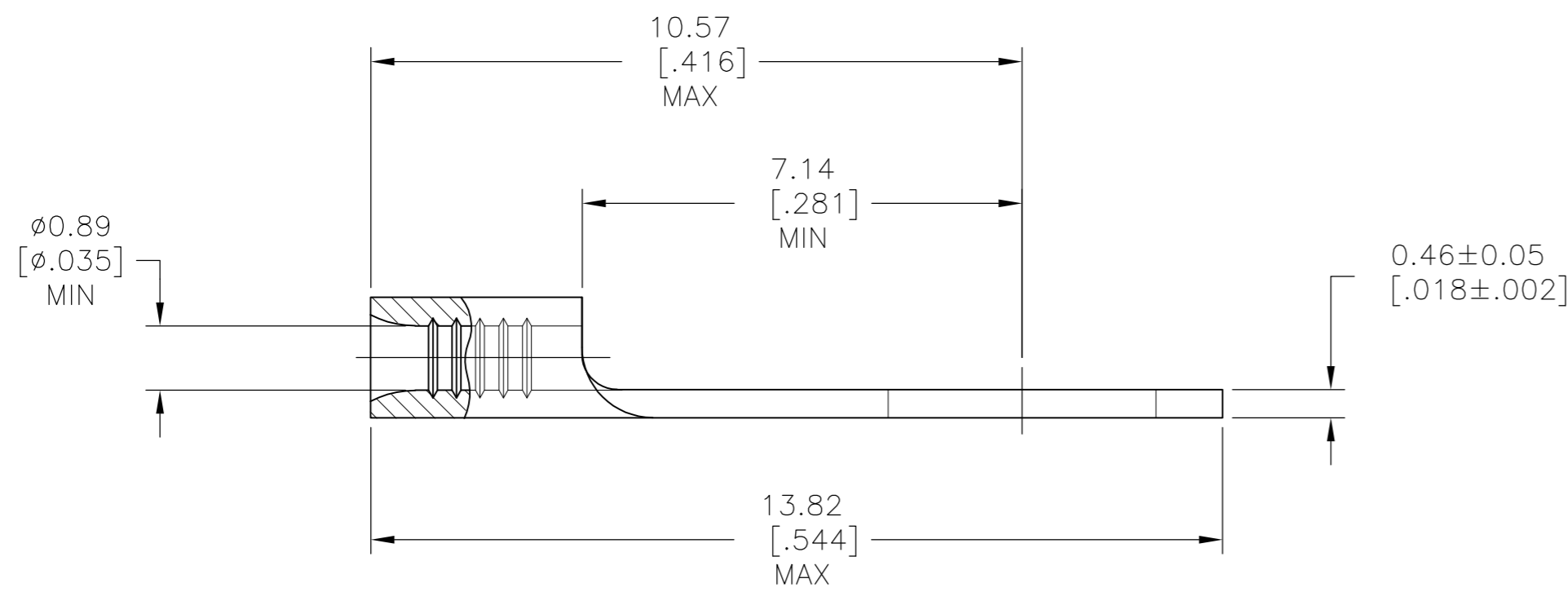

1000	LOOSE PIECE	7	2-32859-4
		4	2-32859-5
		3	32859-1
		2	32859
QTY	PACKAGE TYPE	FINISH	PART NO.

AMP INCORPORATED
CUSTOMER SERVICE SYSTEMS

FOR ADDITIONAL PRODUCT INFORMATION OR COPIES OF DRAWINGS AND TECHNICAL DOCUMENTS: PRODUCT INFORMATION CENTER 1-800-522-6752

FOR APPLICATION TOOLING INFORMATION: TOOLING ASSISTANCE CENTER 1-800-722-1111

FOR ORDER ENTRY: 1-800-526-5142

MAX RECOMMENDED OPERATING TEMPERATURE: 170°C [338°F]

VOLTAGE RATING: N/A

CIRCULAR MIL AREA: 0.1-0.41mm² [202-810] STRANDED

THIS DRAWING IS A CONTROLLED DOCUMENT FOR AMP INCORPORATED. IT IS SUBJECT TO CHANGE AND THE CONTROLLING ENGINEERING ORGANIZATION SHOULD BE CONTACTED FOR THE LATEST REVISION.

THIS DRAWING IS A CONTROLLED DOCUMENT.

DIMENSIONS: mm [INCHES]

TOLERANCES UNLESS OTHERWISE SPECIFIED:

0 PLC	±	-
1 PLC	±	-
2 PLC	±	-
3 PLC	±	-
4 PLC	±	-
ANGLES	±	-

MATERIAL: 5

FINISH: SEE TABLE

DWN: TA BRINKMAN 2-2-93
 CHK: DA PATTERSON 2-2-93
 APVD: JL MECKLEY 2-2-93

NAME: **TE** TE Connectivity

PRODUCT SPEC: TERMINAL, RING TONGUE, BUDGET

APPLICATION SPEC: -

WEIGHT: -

SIZE: A2 CAGE CODE: 00779 DRAWING NO: C-32859 RESTRICTED TO: -

CUSTOMER DRAWING SCALE: 10:1 SHEET: 1 OF 1 REV: D3