

For this drawing we reserve the copyright in accordance with DIN ISO 16016

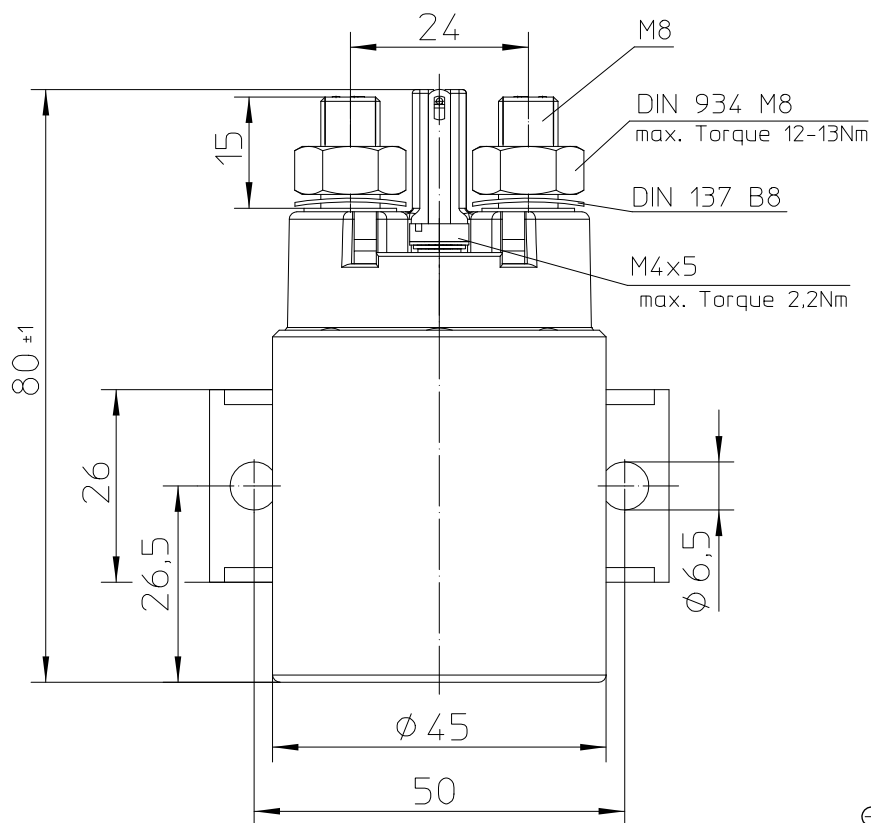

Circuit:

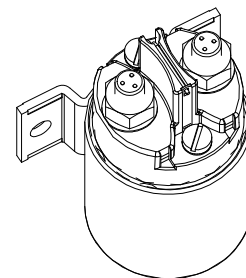
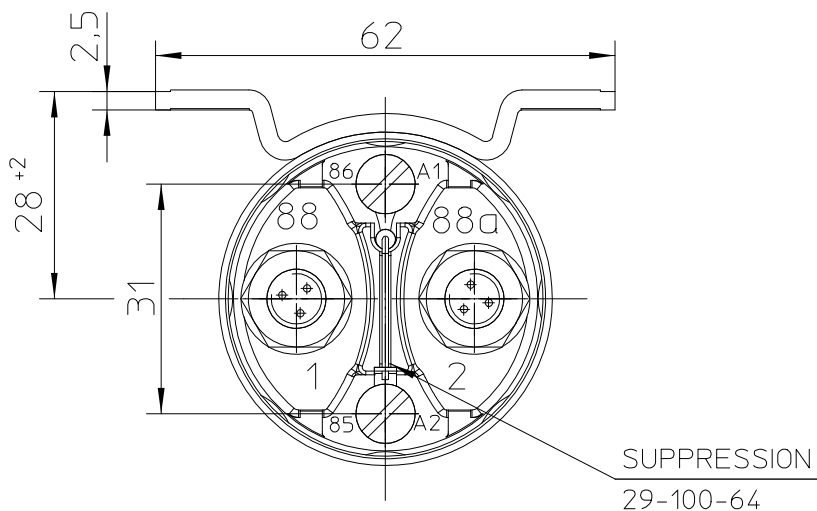
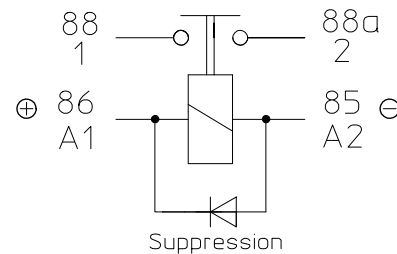

ISO 1:2

	Date	Name
Create	23.11.2015	Seege
Edited	12.10.2020	Seege
Check	12.10.2020	Grind

mm	Scale
\longleftrightarrow	1:1
General Tolerances DIN ISO 2768 cL	



Drawing No:	29-111-12-954
NSN:	

