

THIS DRAWING IS UNPUBLISHED.  
DIFFUSION RESTREINTE

RELEASED FOR PUBLICATION  
LIBRE A LA DIFFUSION

2011

© COPYRIGHT 2011 by Tyco Electronics Corporation

ALL RIGHTS RESERVED.  
TOUS DROITS RESERVES

LOC	DIST
-	-

P		LTR REV	DESCRIPTION MODIFICATIONS	DATE	DWN DESS	APVD APPR
	A	CREATION		06-Jan-15	TC	-

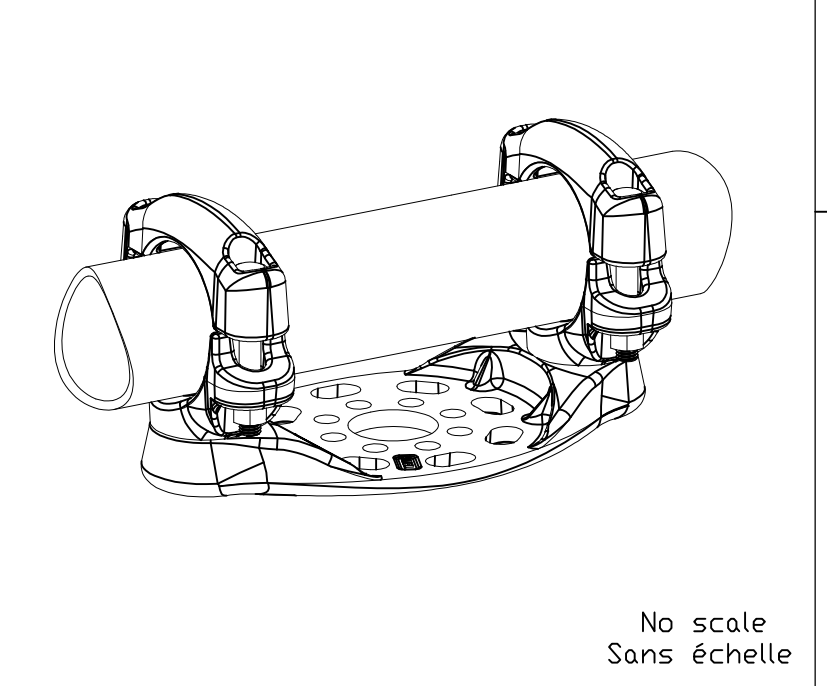
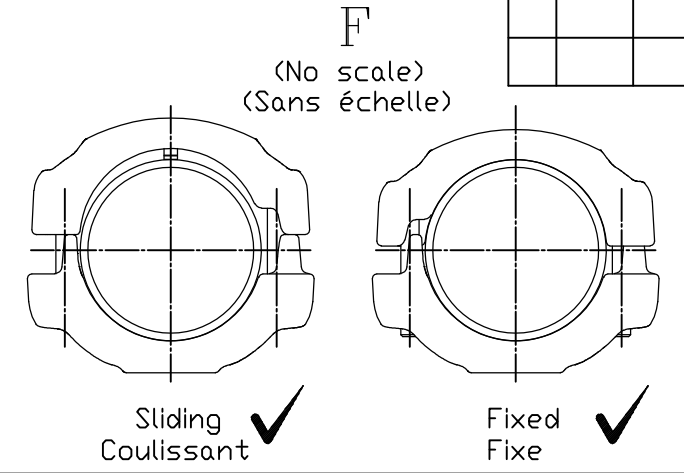
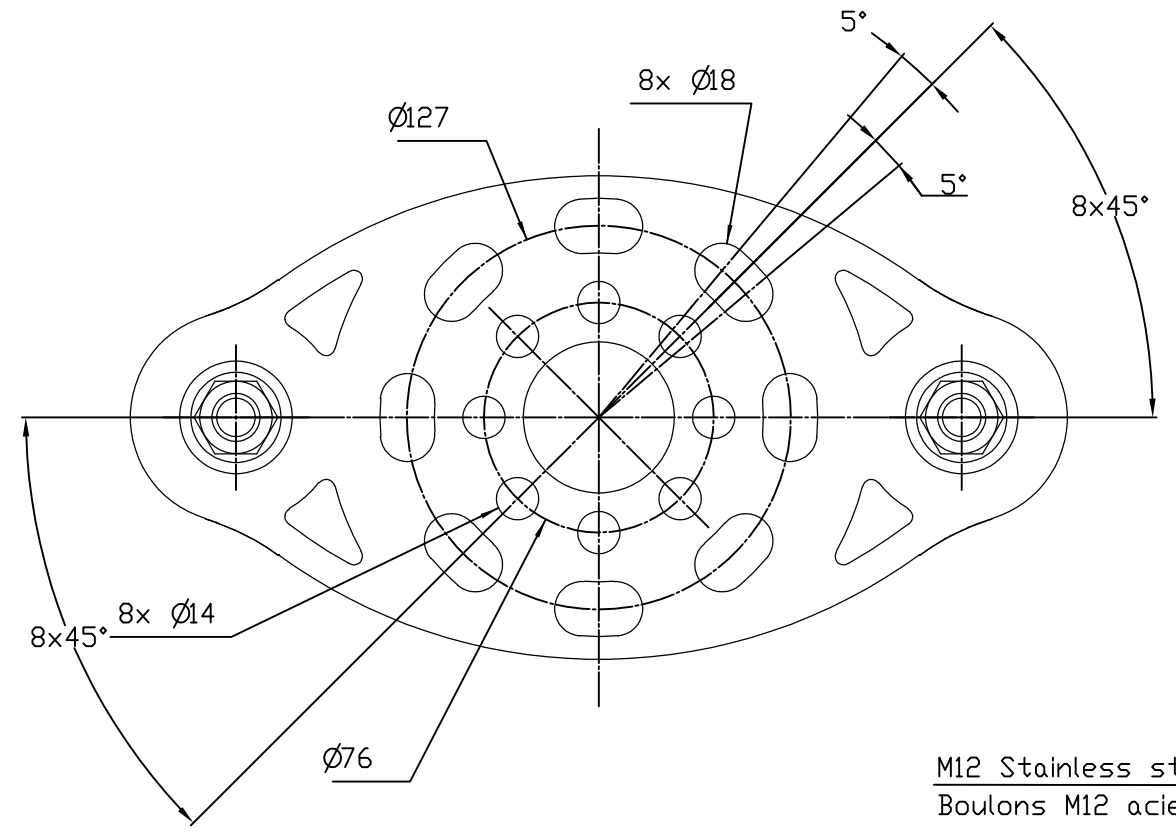

M12 Stainless steel bolts: 60Nm  
Boulons M12 acier inoxydable: 60Nm

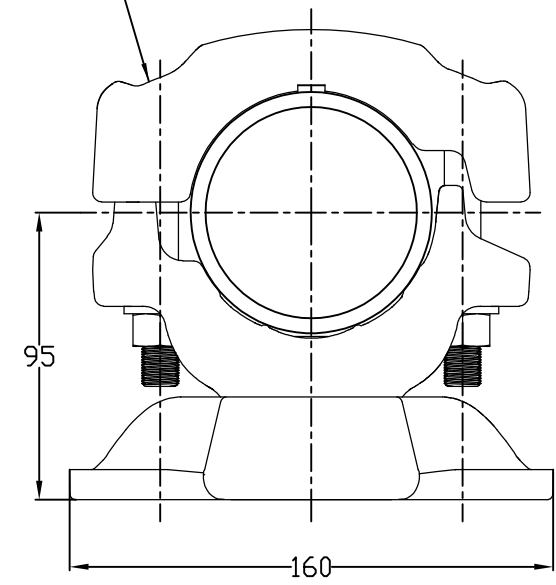
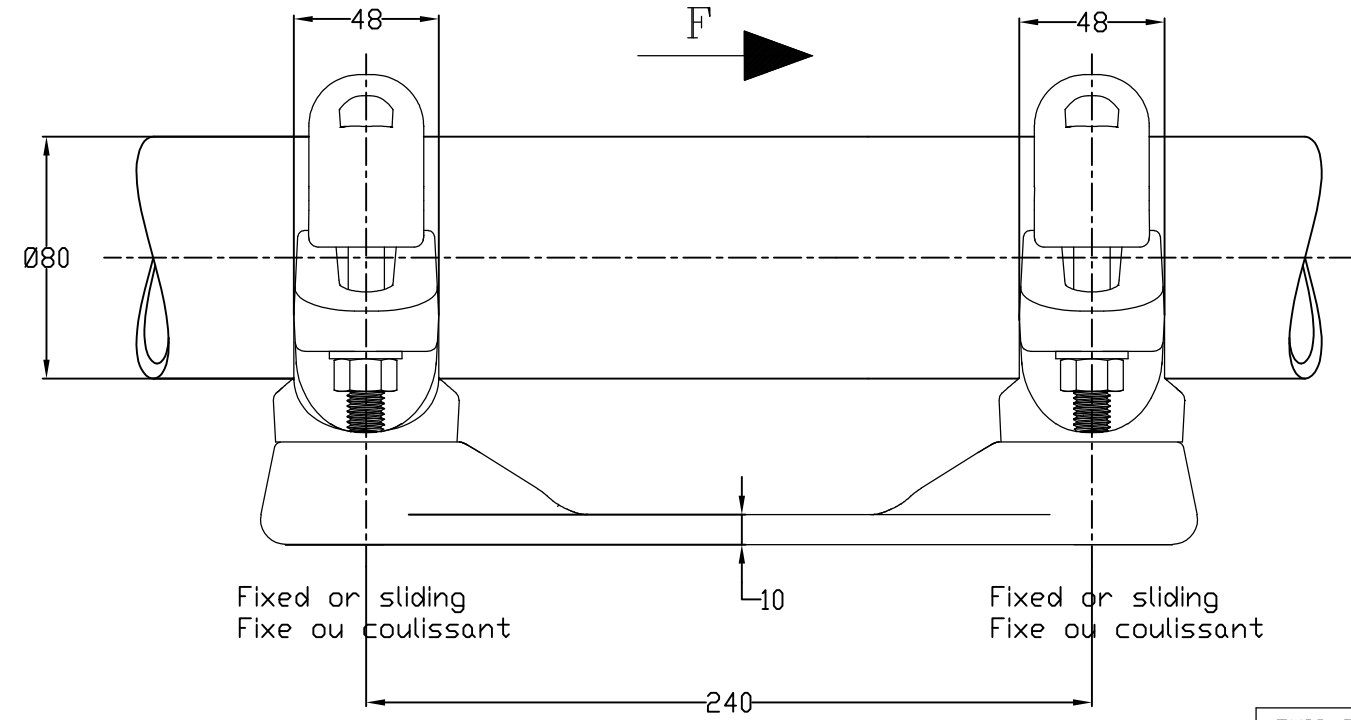

THIS DRAWING IS A CONTROLLED DOCUMENT. CE PLAN EST UN DOCUMENT CONTROLÉ PAR TYCO ELECTRONICS CORPORATION IL EST SUSCEPTIBLE D'ÊTRE REVISÉ. POUR OBTENIR LA DERNIÈRE RÉVISION, CONTACTER LE SERVICE TECHNIQUE DE TYCO ELECTRONICS SIMEL SAS, 21220 GEVREY-CHAMBERTIN, FRANCE.		DWN /DESSINE CHARTON	06-Jan-15	<b>TE connectivity</b> SIMEL PRODUCTS	
DIMENSIONS: mm		CHK/VERIFIE	-		
TOLERANCES UNLESS OTHERWISE SPECIFIED PER TOLERANCES NON SPECIFIEES SELON :-		APVD/APPROUVE	-	NAME TITRE Ø80 BUSBAR SUPPORT ON P5 BPI SUPPORT TUBE Ø80 SUR ISO P5 5 TSD 82 P3- P5 T80	
MATERIAL MATIERE		PRODUCT SPEC SPEC. PRODUIT	108-69090-001	SIZE FORMAT	A3
FINISH FINITION		APPLICATION SPEC SPEC. APPLICATION	-	CAGE CODE	00779
-		APPROX. WEIGHT MASSE APPROX.	3.15 Kg	DRAWING NO No PLAN	©=2839495
-		CUSTOMER DRAWING /PLAN CLIENT		UNIQUEMENT POUR REFERENCE	SCALE ECHELLE 2/5
-				SHEET FEUILLE 1	OF DE 1
-				REV	A

ITEM:.....