

P	LTR	DESCRIPTION	DATE	DWN	APVD
N4		PART STATUS UPDATED	15FEB2018	RK	PS
P		STANDARDIZATION OF PLATING AND SPLICING	13AUG2024	GVP	KJK

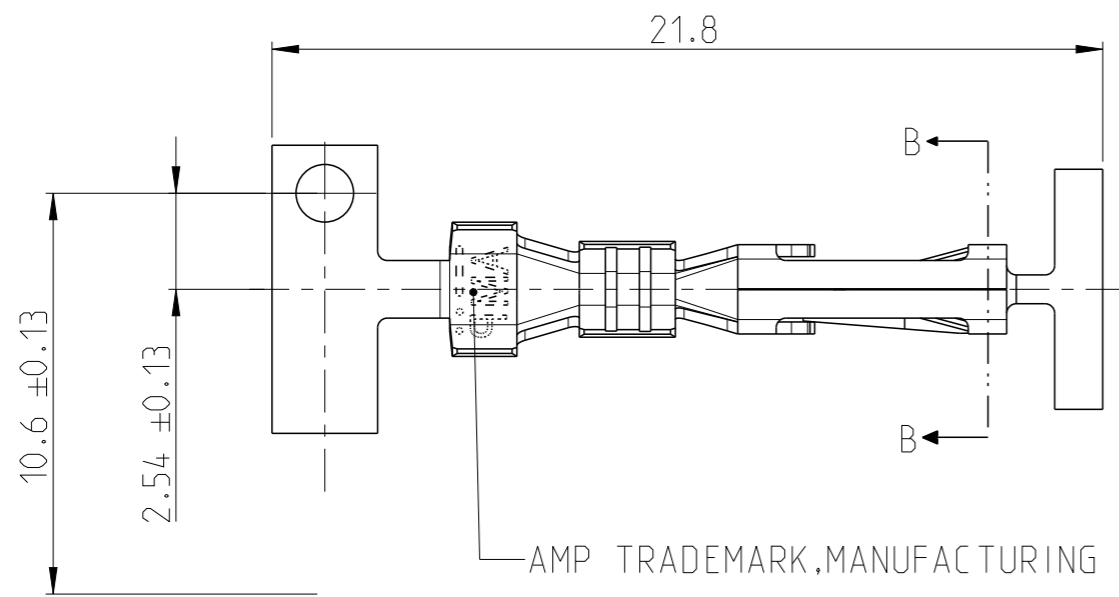

AMP TRADEMARK, MANUFACTURING LOCATION CODE.

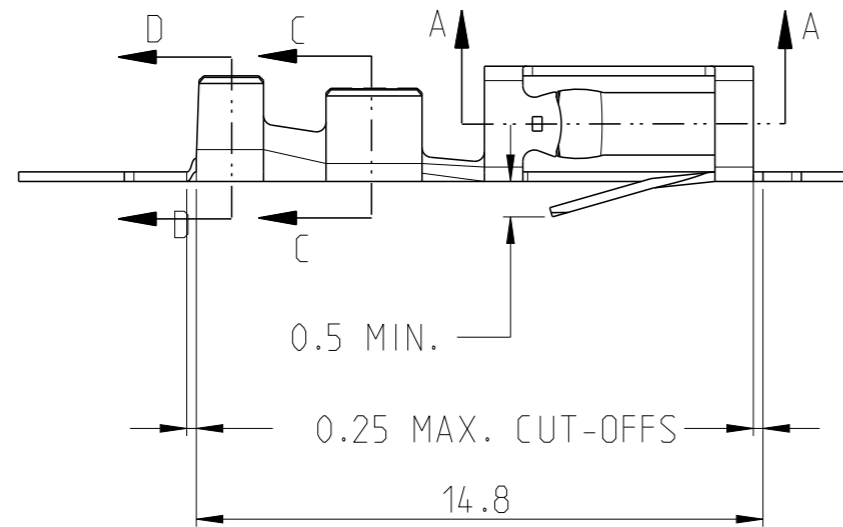
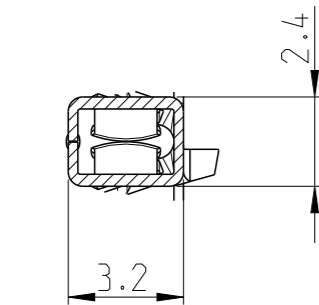

SECTION B-B

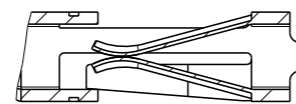

SECTION A-A

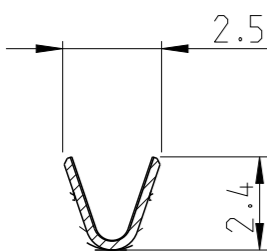

SECTION C-C

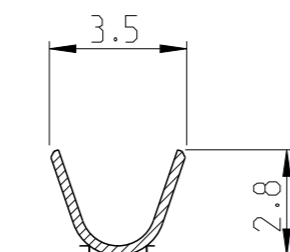

SECTION D-D

NOTE (NOTES)

- MATERIAL: PHOSPHOR BRONZE.
- FINISH: TIN PLATED 0.8 μm ALL OVER EXCEPT FOR CUTTING EDGES
- FINISH: GOLD PLATED 0.4 μm IN CONTACT AREA AND GOLD FLASH ON REMAINDER EXCEPT FOR CUTTING EDGES (GOLD FLASH IS NOT MANDATORY ON THE PILOTTED CARRIER STRIP) OVER 0.8 μm NICKEL.
- FINISH: GOLD PLATED 1.3 μm IN CONTACT AREA AND GOLD FLASH ON REMAINDER, OVER 0.8 μm NICKEL.
- FINISH: GOLD PLATED 0.8 μm IN CONTACT AREA AND GOLD FLASH ON REMAINDER, OVER 0.8 μm NICKEL.
- FOR MINI APPLICATOR P/N 90274-2.
- FOR HANDTOOL P/N 90274-2.
- OBsolete PARTS: OBSOLETE CIS STREAMLINING PER D.RENAUD/D.SINISI
- SPLICING - MAXIMUM 1 LOOSE END PER REEL IS ALLOWED.

OBsolete	NOTES	Part Number	Part Number
	NOTES 1 & 5	181299-6	280621-6
	NOTES 1 & 4	181299-4	280621-4 ⚠
	NOTES 1 & 3	181299-2	280621-2
	NOTES 1 & 2	181299-1	280621-1
	MATL. & FINISH	LOOSE PIECE PART MATERIAL, NOTE 7	STRIP PART NUMBER, NOTE 6

INS. DIA. RANGE	WIRE RANGE	CUSTOMER DWG. FOR REFERENCE ONLY	
1.8-2.3 mm	0.32-0.9 mm ² (22-18 AWG)	THIS DRAWING IS UNPUBLISHED	RELEASE FOR PUBLICATION 19

THIS DRAWING IS A CONTROLLED DOCUMENT.		DWN G. CAMPIA 01JUN1989		
DIMENSIONS: mm		CHK -		
TOLERANCES UNLESS OTHERWISE SPECIFIED: ±0.3		APVD -	NAME AMP MODU I REC. CONTACT, STD. PRESSURE, C.O.S.I.	
0 PLC ±		PRODUCT SPEC 108-20026	SIZE CAGE CODE DRAWING NO RESTRICTED TO	
1 PLC ±		APPLICATION SPEC 114-20040	A3 00779 C=280621	
2 PLC ±		WEIGHT -	SCALE 5:1 SHEET 1 OF 1 REV P	
3 PLC ±		CUSTOMER DRAWING		
4 PLC ±				
ANGLES ±2°				
MATERIAL -				
FINISH -				