

REVISIONS				
P.	LTM	DESCRIPTION	DATE	APVD
1		PROPOSED	08JUN2017	REH KS

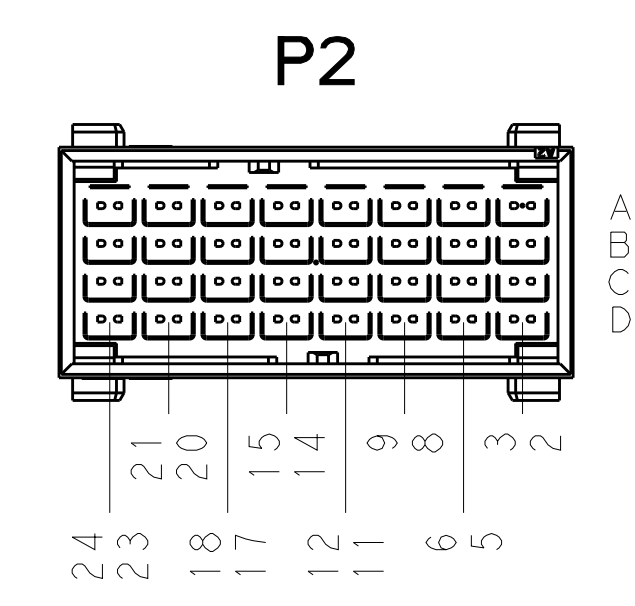

1 LABEL INFORMATION:

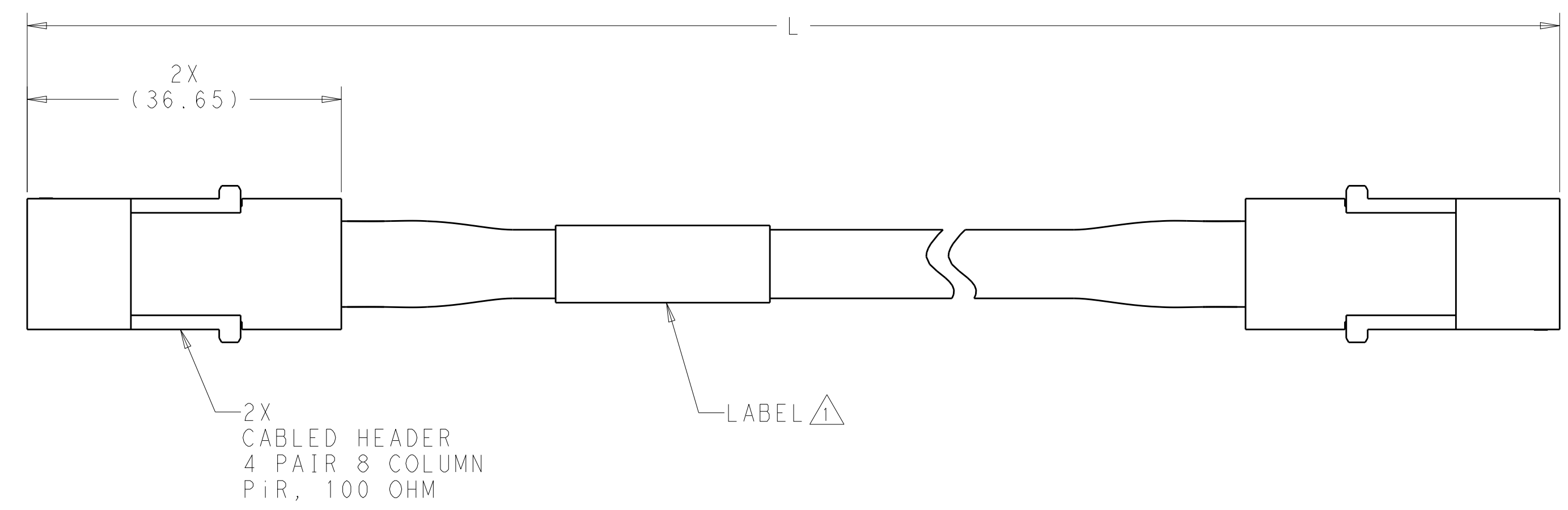
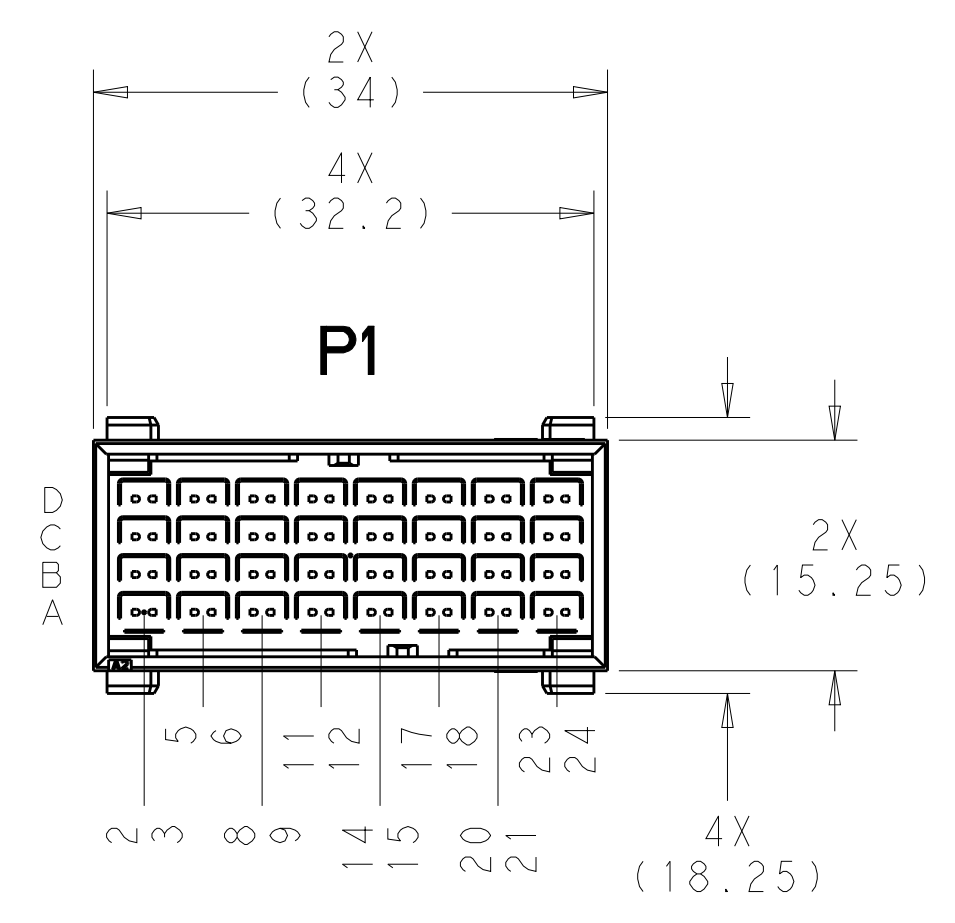
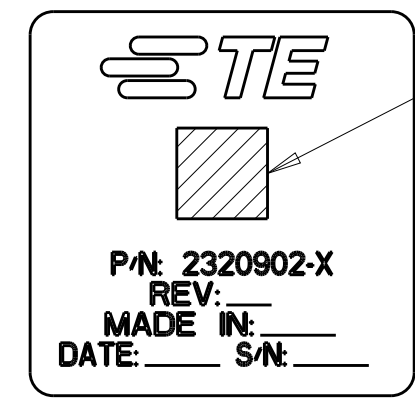

BARCODE INFO:
 2320902-dxxwyysss
 d=DASH NUMBER
 xx=MANUFACTURING SITE
 US=UNITED STATES, CN=CHINA, MX=MEXICO
 ww=WEEK
 yy=YEAR
 sss=SERIAL NUMBER 000 THRU 999

1508	6-2320902-6
1008	5-2320902-6
508	3-2320902-6
L±3	PART NUMBER

- EACH CABLE ASSEMBLY TESTED FOR CONTINUITY, OPENS AND SHORTS.
- SEE SHEET 2 FOR WIRING DIAGRAM.
- EACH HIGH SPEED CABLET TESTED ON NETWORK ANALYZER, SERIALIZED, AND DATA SAVED.

THIS PRODUCT HAS NOT COMPLETED VALIDATION AND QUALIFICATION TESTING

PRELIMINARY NOT RELEASED FOR PRODUCTION

DIMENSIONS:		TOLERANCES UNLESS OTHERWISE SPECIFIED:		MATERIAL:		FINISH:	
mm	0 PLC	±					
	1 PLC	±					
	2 PLC	±					
	3 PLC	±					
	4 PLC	±					
	ANGLES	±					

THIS DRAWING IS A CONTROLLED DOCUMENT.		DWN: HAMNER 08JUN2017	STE Connectivity	
CHK: K. SAMMON 15JUN2017	APVD: K. SAMMON 15JUN2017	NAME: CABLE ASSEMBLY, 100 OHM, PiR, 4 PAIR, 8 COLUMN, 20G, 2-2 WIRING, A-D	SIZE: A1	RESTRICTED TO: -
MATERIAL: -		WEIGHT: -	SCALE: 2:1	SHEET 1 OF 2
Customer Drawing		DRAWING NO: C=2320902	REV: 1	

REVISIONS				
P.	LTN.	DESCRIPTION	DATE	APVD.
-	-	SEE SHEET 1	-	-

WIRING DIAGRAM

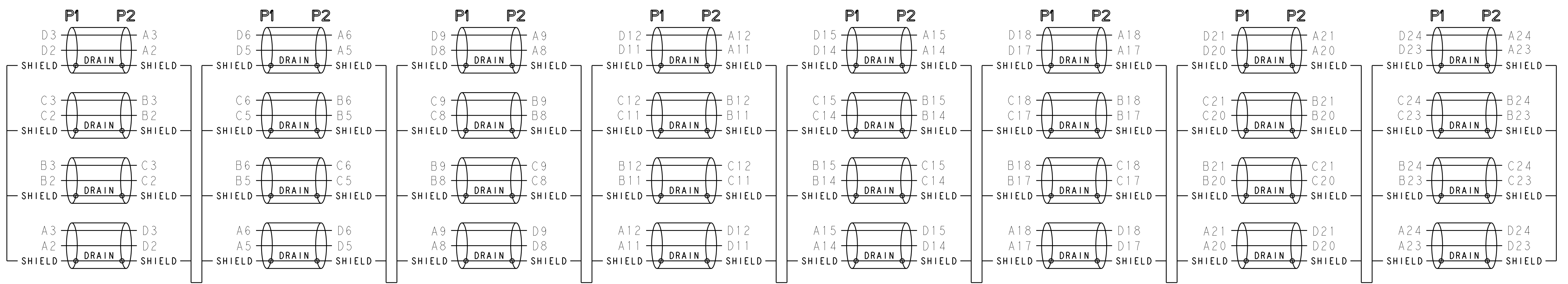

THIS PRODUCT HAS NOT COMPLETED VALIDATION AND QUALIFICATION TESTING

PRELIMINARY NOT RELEASED FOR PRODUCTION

THIS DRAWING IS A CONTROLLED DOCUMENT.		OWN: HAMNER 08JUN2017	TE Connectivity
DIMENSIONS: mm		CHK: K. SAMMON 15JUN2017	
TOLERANCES UNLESS OTHERWISE SPECIFIED:		APVD: K. SAMMON 15JUN2017	NAME: CABLE ASSEMBLY, 100 OHM, PiR, 4 PAIR, 8 COLUMN, 20G, 2-2 WIRING, A-D
0 PLC ±	1 PLC ±	PRODUCT SPEC	SIZE: A1
2 PLC ±	3 PLC ±	APPLICATION SPEC	CAGE CODE: -
4 PLC ±	ANGLES ±	WEIGHT: -	DRAWING NO: C=2320902
MATERIAL: -	FINISH: -	Customer Drawing	RESTRICTED TO: -
SCALE: 2:1			SHEET: 2 OF 2
REV: 1			REV: 1