

THIS DRAWING IS UNPUBLISHED.		RELEASED FOR PUBLICATION	
© COPYRIGHT - By -		ALL RIGHTS RESERVED.	
PROJECT	PRJ-16-000909157		
PART NO.	X-2308265-X		
DESCRIPTION	QL SET FOR VARIANT B		
CUSTOMER	GENERAL MARKET		

REVISIONS					
P	LTR	DESCRIPTION	DATE	DWN	APVD
	A3	REVISED PER ECR-17-006621	09MAY2017	KK	SE

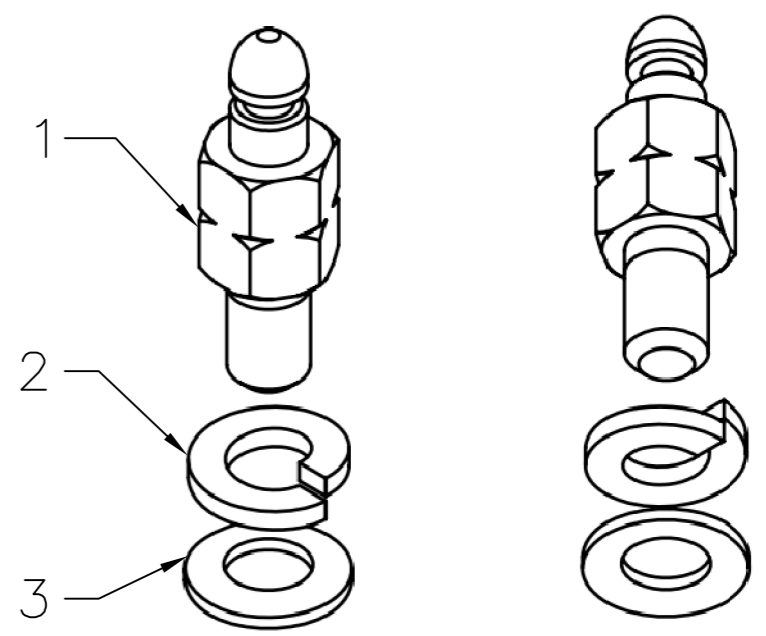
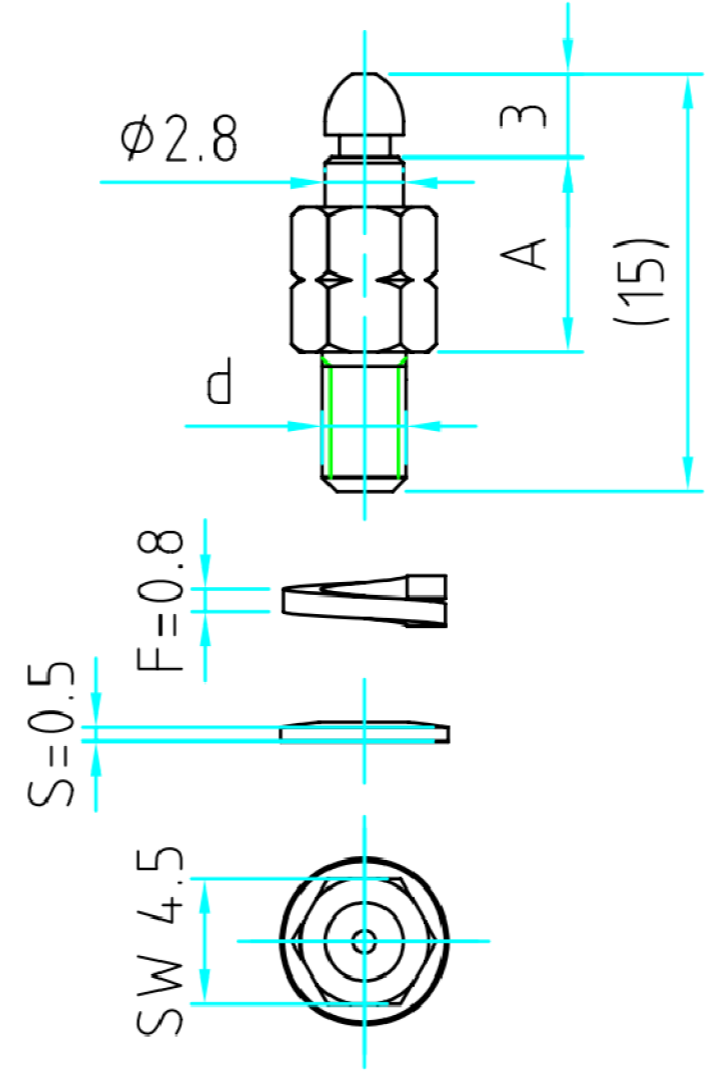
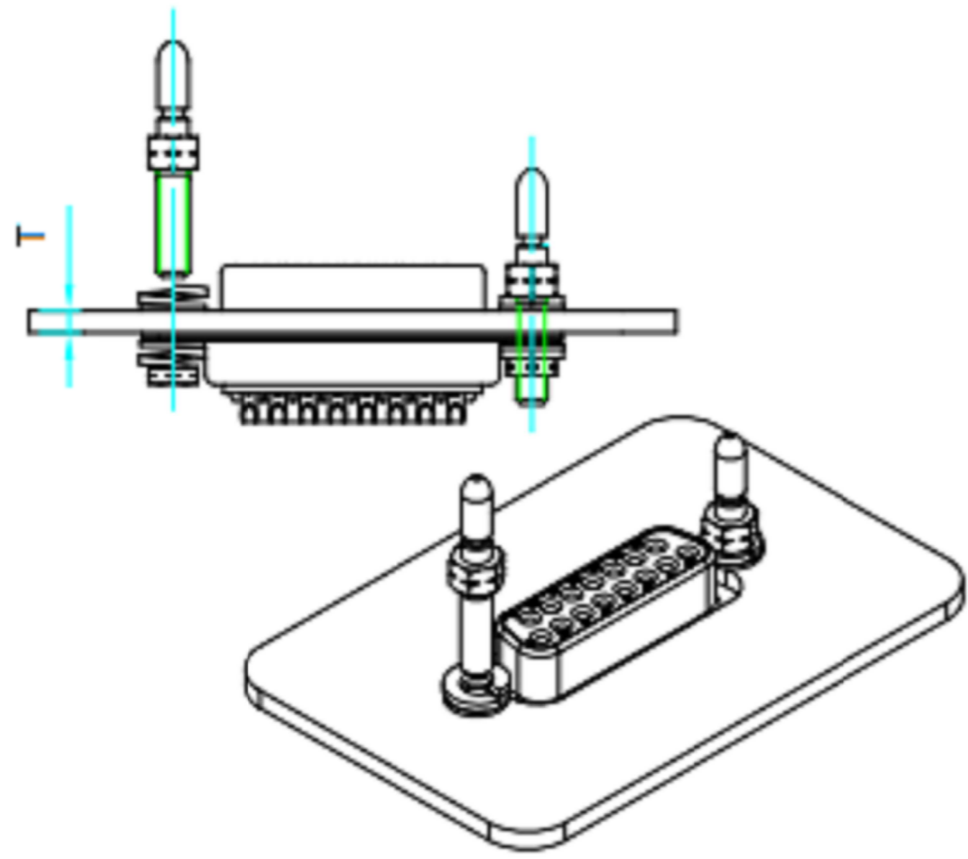

PART-NO.	DESCRIPTION	A	d	POS.1		POS.1 M 1:1	POS.3, QTY	T, mm
				PART-NO.	DESCRIPTION			
1-2308265-1	QL VARIANT B 1	7.0	4-40 UNC	1-2308352-3	LATCH PIN 3 (UNC)		-	-
1-2308265-2	QL VARIANT B 2	5.5		1-2308352-4	LATCH PIN 4 (UNC)		2	1.0 - 1.3
1-2308265-3	QL VARIANT B 3	5.5		-	-	-	-	1.5 - 1.8
1-2308265-4	QL VARIANT B 4	4.8		1-2308352-6	LATCH PIN 6 (UNC)		2	1.7 - 2.0
1-2308265-5	QL VARIANT B 5	4.8		-	-	-	-	2.2 - 2.5
1-2308265-6	QL VARIANT B 6	7.0	M3	3-2308352-5	LATCH PIN 25 (METRIC)		-	-
1-2308265-7	QL VARIANT B 7	5.5		3-2308352-6	LATCH PIN 26 (METRIC)		2	1.0 - 1.3
1-2308265-8	QL VARIANT B 8	5.5		-	-	-	-	1.5 - 1.8
1-2308265-9	QL VARIANT B 9	4.8		3-2308352-7	LATCH PIN 27 (METRIC)		2	1.7 - 2.0
2-2308265-0	QL VARIANT B 10	4.8		-	-	-	-	2.2 - 2.5

NOTES:

1. WALL THICKNESS T SPECIFIED FOR REAR WALL MOUNTING.
2. DISC POS.3 IS CONDITIONALLY USED (SEE TAB).
3. IMPORTANT: IF QL-SET CORRECTLY CHOSEN THEN THE SUM T + A + F + S SHOULD LIE IN 7.8-8.1mm RANGE.
4. WEIGHT: 1.1 g.
5. FINISHING PROCESS: 4-7 μ Sn OVER 2-3 μ Cu.

SL. NO.	QTY	PART-NO.	DESCRIPTION
3	SEE TAB.	-	DISC WASHER A3 DIN 433 STAINLESS STEEL
2	2	-	SPRING WASHER B3 DIN 127 STAINLESS STEEL
1	2	SEE TAB.	LATCH PIN

THIS DRAWING IS A CONTROLLED DOCUMENT.		DWN KIRAN K 27JUL2016	TE Connectivity	
DIMENSIONS: mm		CHK GUNASEKHAR G 27JUL2016		
TOLERANCES UNLESS OTHERWISE SPECIFIED: DIN ISO 2768 m		APVD GUNASEKHAR G 27JUL2016	NAME QL SET FOR VARIANT B	
0 PLC ± - 1 PLC ± - 2 PLC ± - 3 PLC ± - 4 PLC ± - ANGLES ± -		PRODUCT SPEC	RESTRICTED TO	
MATERIAL		APPLICATION SPEC	SIZE A2	CAGE CODE 00779
FINISH		WEIGHT	DRAWING NO C=2308265	SCALE NTS
		CUSTOMER DRAWING	SHEET 1 of 1	REV A3