

REVISIONS				
P	LTR	DESCRIPTION	DATE	DWN APVO
E		ECR-23-163379	11JAN2023	RRD CZ

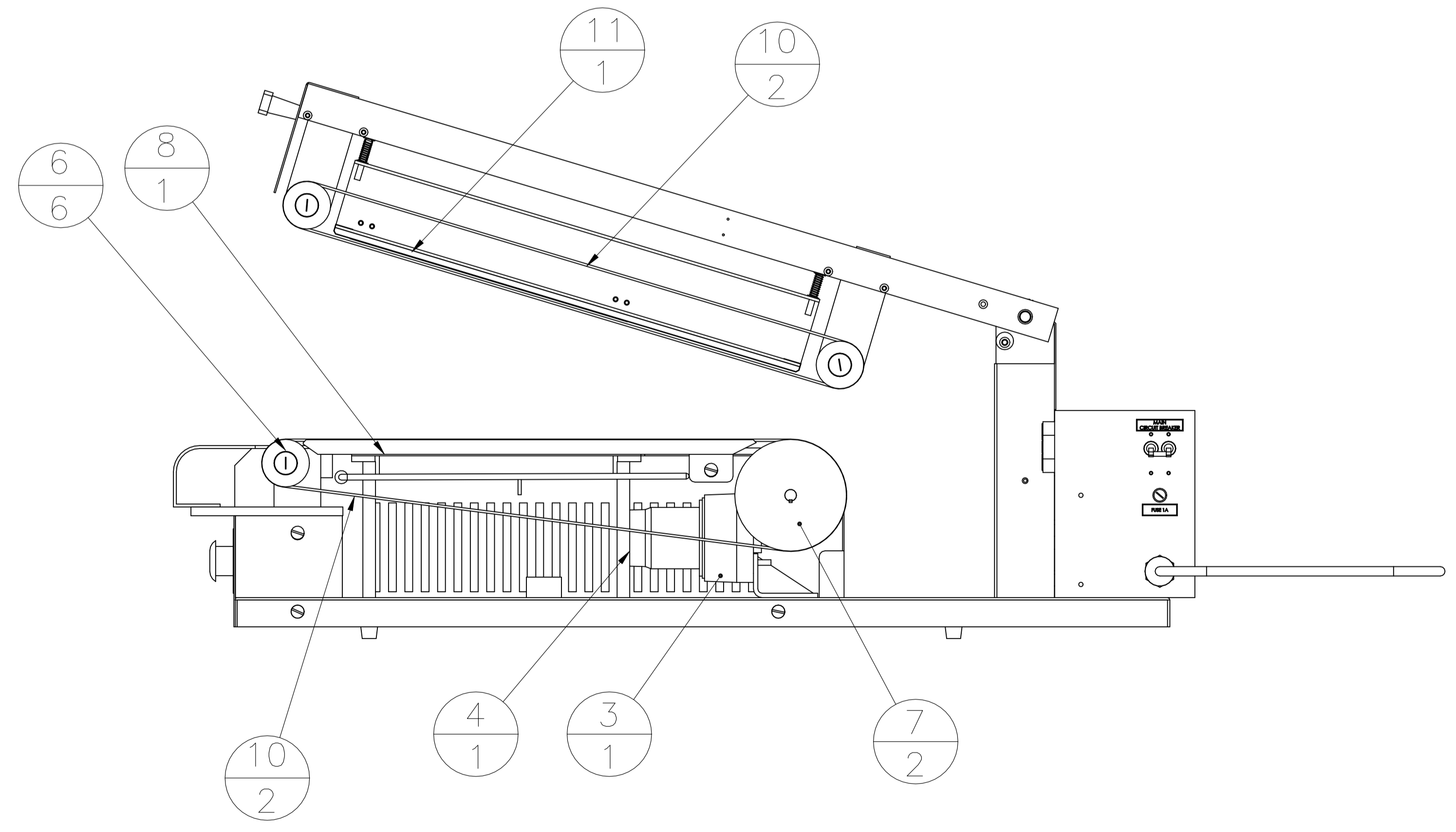
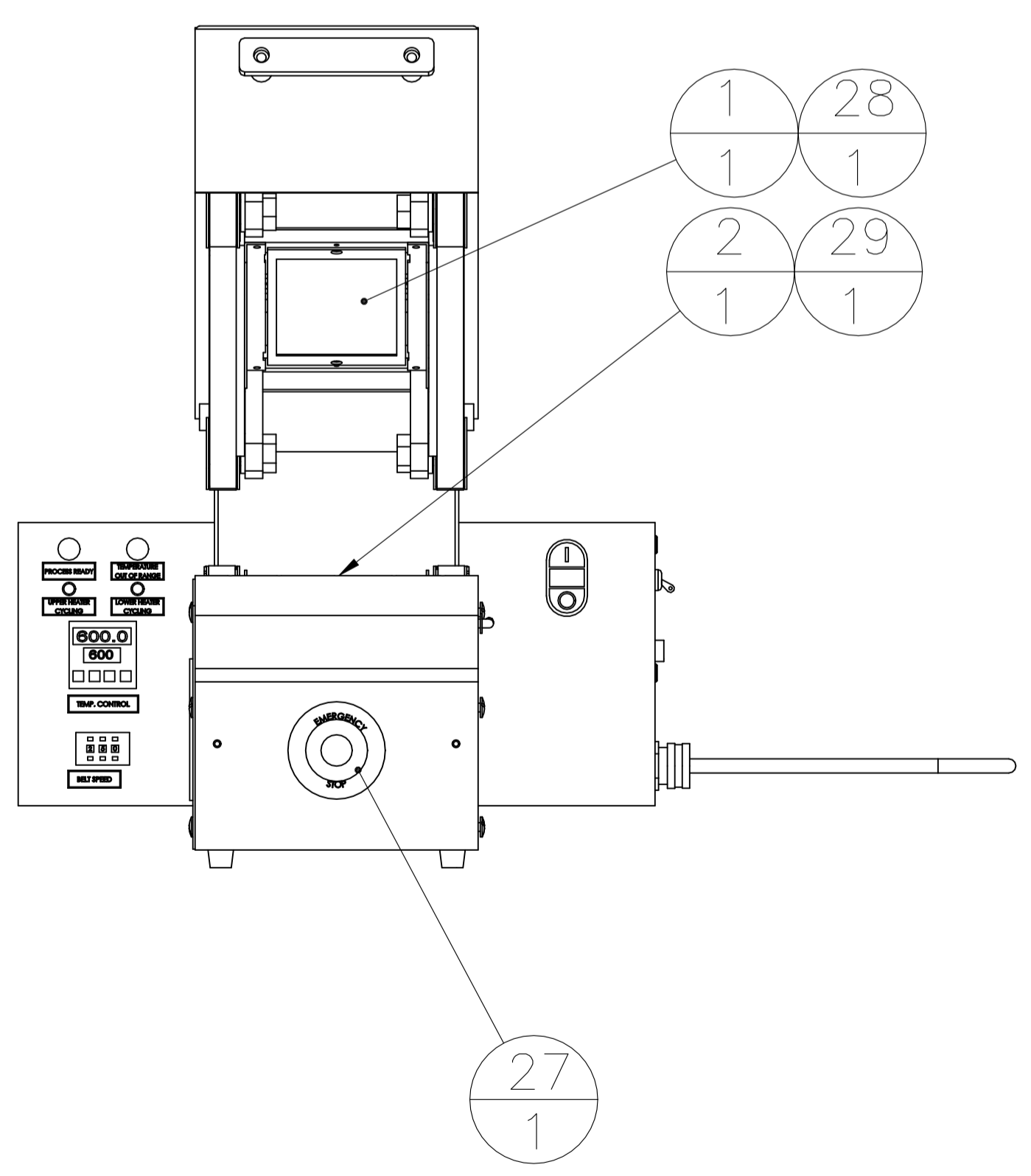
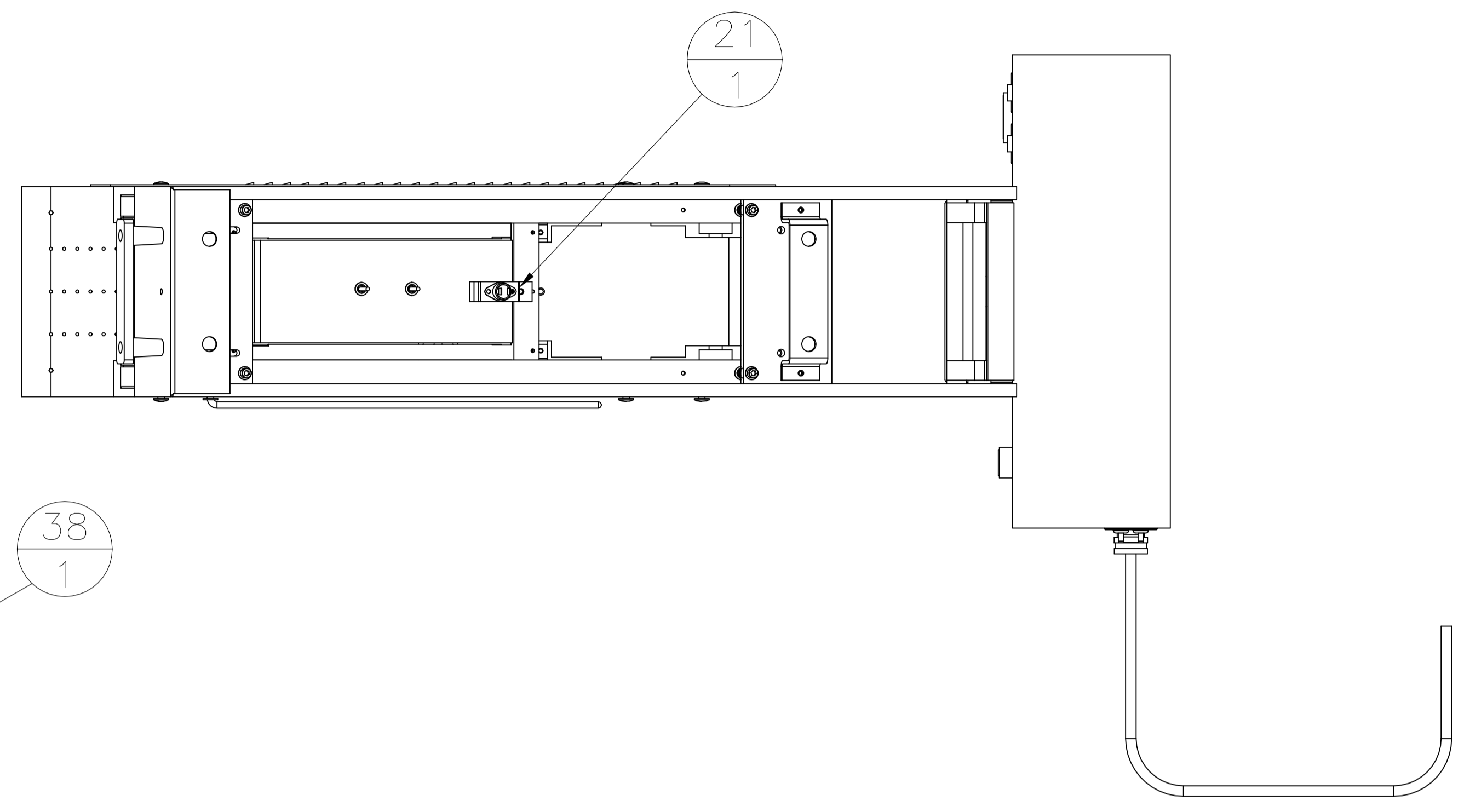
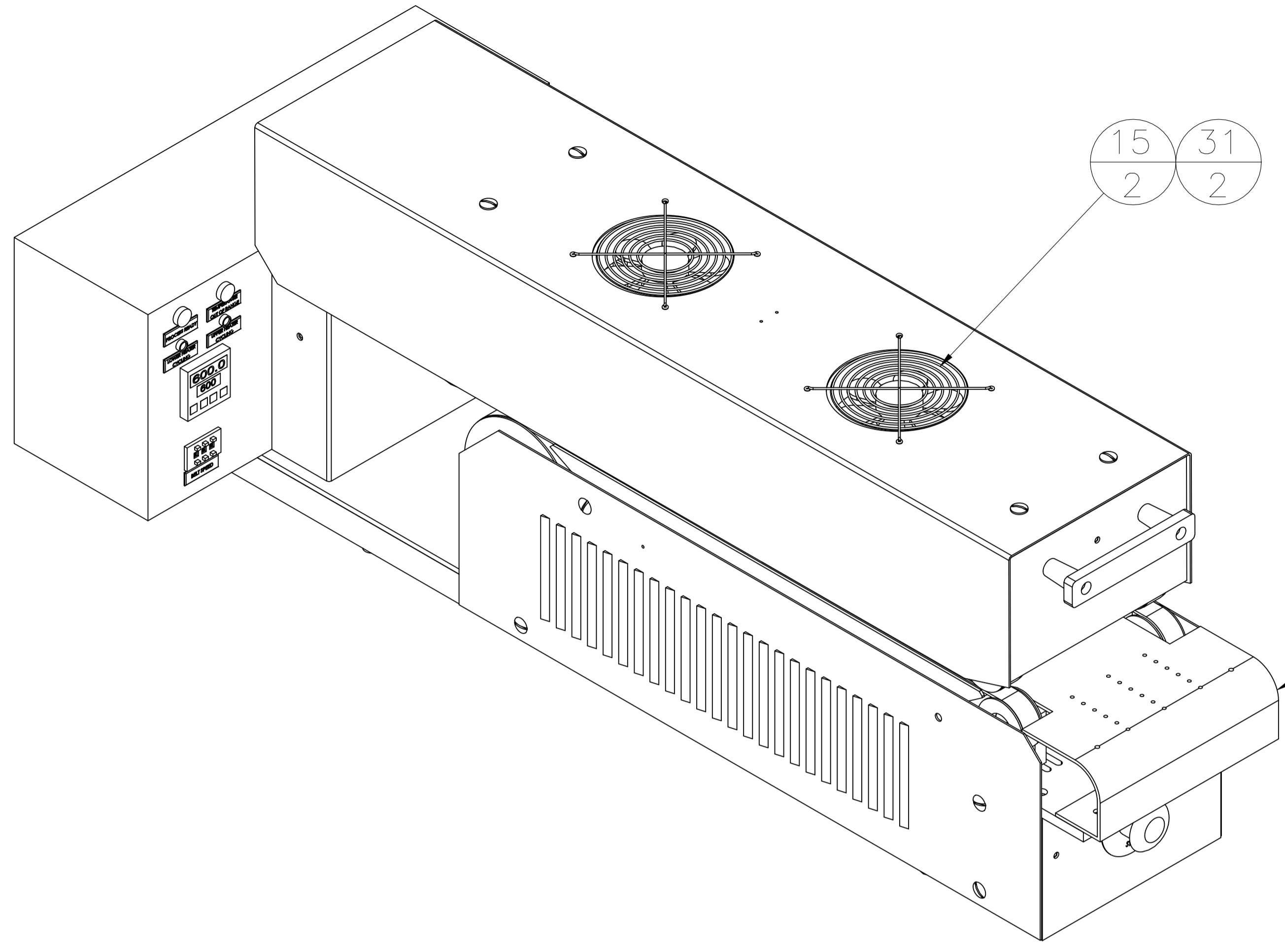

THIS DRAWING IS A CONTROLLED DOCUMENT.		DWN Kiran_Holal 12FEB2015	TE Connectivity
DIMENSIONS: INCHES		CHK C Kerstetter 12FEB2015	
TOLERANCES UNLESS OTHERWISE SPECIFIED:		APVO C Kerstetter 12FEB2015	NAME MODEL 17 BELT HEATER
0. PLC	±	PRODUCT SPEC	
1. PLC	±	APPLICATION SPEC	
2. PLC	±	SIZE	A1
3. PLC	±	CAGE CODE	00779
4. PLC	±	DRAWING NO	C=2280355
ANGLES	±	WEIGHT	0
MATERIAL		CUSTOMER DRAWING	SCALE 1:1 SHEET 1 OF 4 REV E

REVISIONS				
P	LTR	DESCRIPTION	DATE	APPRO
-	-	SEE SHEET 1	-	-

# UPPER HEATER ASSEMBLY

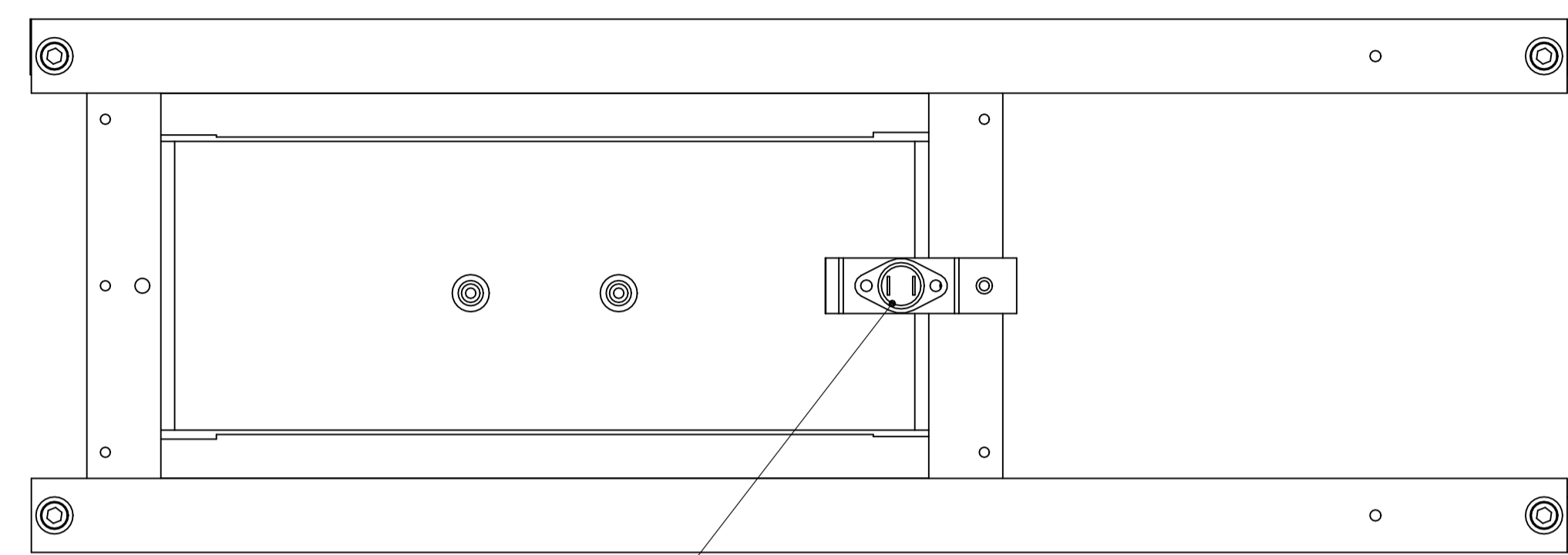

21  
1

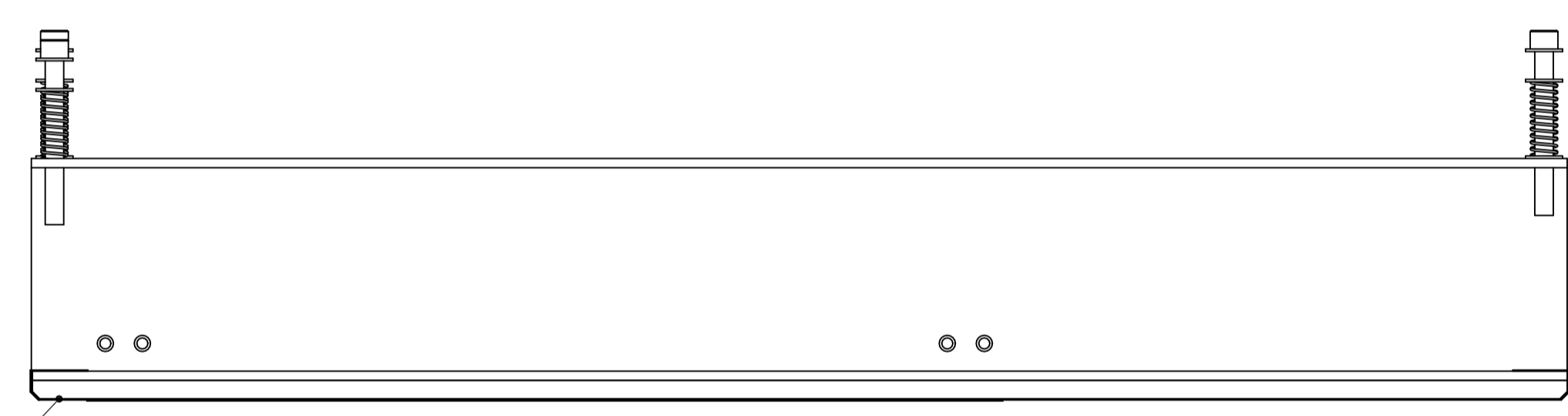

11  
2

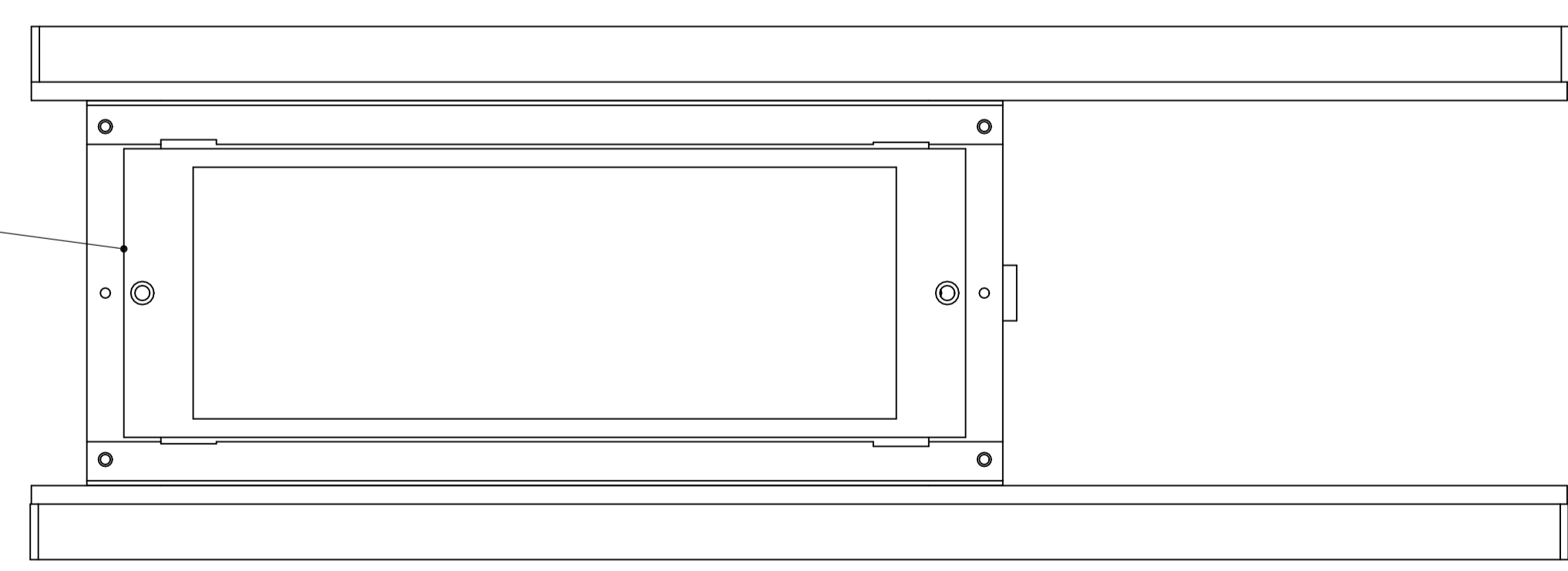

28  
1

1  
1

THIS DRAWING IS A CONTROLLED DOCUMENT.		DWN Kiran_Holal 12FEB2015	
DIMENSIONS: INCHES		CHK C Kerstetter 12FEB2015	
TOLERANCES UNLESS OTHERWISE SPECIFIED:		APPRO C Kerstetter 12FEB2015	NAME MODEL 17 BELT HEATER
0. PLC	± .005	PRODUCT SPEC	SIZE A1
1. PLC	± .010	APPLICATION SPEC	CAGE CODE 00779
2. PLC	± .015	WEIGHT	DRAWING NO C=2280355
3. PLC	± .020	CUSTOMER DRAWING	RESTRICTED TO
4. PLC	± .030	SCALE 1:1	SHEET 2 of 4
ANGLES	± .005	REV E	

REVISIONS				
P	LTR	DESCRIPTION	DATE	APVD
-	-	SEE SHEET 1	-	-

# CONTROL PANEL LAYOUT

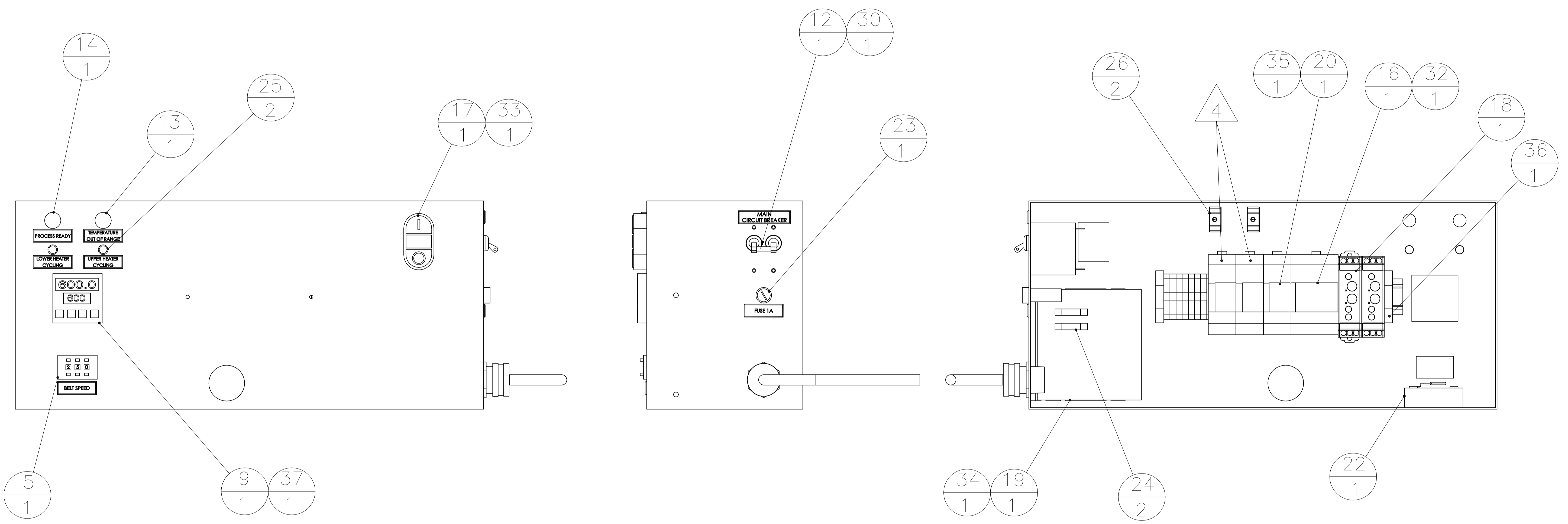

THIS DRAWING IS A CONTROLLED DOCUMENT.		DWN: Kiran_Holal 12FEB2015		TE Connectivity	
DIMENSIONS: INCHES		CHK: C Kerstetter 12FEB2015			
TOLERANCES UNLESS OTHERWISE SPECIFIED:		APVD: C Kerstetter 12FEB2015		NAME: MODEL 17 BELT HEATER	
0. PLC ± - 1. PLC ± - 2. PLC ± - 3. PLC ± - 4. PLC ± - ANGLES ± -		PRODUCT SPEC		RESTRICTED TO	
MATERIAL		WEIGHT		SIZE: A1 00779 C=2280355	
FINISH		CUSTOMER DRAWING		SCALE: 1:1 SHEET 3 OF 4 REV E	

REVISIONS				
P	LTR	DESCRIPTION	DATE	APPRO
-	-	SEE SHEET 1	-	-

- 1 PART IS SPECIFIC TO 2280355-1 AND -2 MACHIES ONLY. (220 VAC VERSION)
- 2 PART IS SPECIFIC TO 2280355-3 AND -4 MACHINES ONLY. (110 VAC VERSION)
- 3 FOR 2280355-4 VERSION ONLY.
- 4 FOR 2280355-3, 1 IS REQUIRED (1CR). FOR 2280355-4, 3 ARE REQUIRED PER MACHINE (1CR, 2CR, 3CR).

# SPARE PARTS LIST

ITEM	QTY	TE PART NUMBER	DESCRIPTION
1	1	2280624-1	UPPER HEATER ELEMENT, IR, 1000 W, 240 VAC, W/TYPE K T/C (STANDARD WIDTH)
2	1	2280624-2	LOWER HEATER ELEMENT, IR, 1000 W, 240 VAC, W/O TYPE K T/C (STANDARD WIDTH)
3	1	2280624-3	DRIVE MOTOR, 1/50 HP, 90VDC
4	1	2280624-4	REPLACEMENT BRUSH SET (2)
5	1	2280624-5	SPEED POTENTIOMETER CONTROLLER
6	6	2280624-6	IDLER PULLEY ASSEMBLY
7	2	2280624-7	DRIVE PULLEY
8	1	2280624-8	LOWER PHENOLIC BELT GUIDES (SET OF 2)
9	1	2280624-9	PARTLOW TEMPERATURE CONTROLLER, PROGRAMMED
10	4	1-2280624-0	TIMING BELT, D540L075
11	1	1-2280624-1	FOAM PAD BELT BACKUP SET
12	1	1-2280624-2	MAINS CIRCUIT BREAKER 250VAC 15Amp
13	1	1-2280624-3	TEMPERATURE OUT OF RANGE LIGHT, 220VAC, RED
14	1	1-2280624-4	PROCESS READY LIGHT, 220 VAC, GREEN
15	2	1-2280624-5	COOLING FAN, 220VAC
16	1	1-2280624-6	MCR, 4 POLE, 220VAC
17	1	1-2280624-7	POWER ON, OFF MODULE w/220VAC NEON INDICATOR LAMP
18	1	1-2280624-8	COOL DOWN TIMER, 220VAC
19	1	1-2280624-9	SCR MOTOR CONTROLLER, 220VAC x 90VDC, w/0.51 Ohm HORSEPOWER RESISTOR, ASSEMBLED
20	1	2-2280624-0	CONTROL RELAY, 1CR, 2 POLE 230VAC
21	1	2-2280624-1	OVER TEMPERATURE SWITCH
22	1	2-2280624-2	SOLID STATE RELAY
23	1	2-2280624-3	FUSE, IEC 5x20mm, HIGH BREAKING, TIME DELAY, 250V, 1.0A
24	2	2-2280624-4	FUSE, MDL-1
25	2	2-2280624-5	HEATER CYCLING LED
26	2	2-2280624-6	HEATER CYCLING CURRENT RING
27	1	2-2280624-7	EMERGENCY STOP PUSHBUTTON ASSEMBLY
28	1	2-2280624-8	UPPER HEATER ELEMENT, IR,1000W, 115 VAC, W/TYPE K T/C
29	1	2-2280624-9	LOWER HEATER ELEMENT, IR,1000W, 115 VAC, W/O TYPE K T/C
30	1	3-2280624-0	MAINS CIRCUIT BREAKER 250 VAC 20 AMP
31	2	3-2280624-1	COOLING FAN, 115 VAC
32	1	3-2280624-2	MCR, 4 POLE, 115 VAC
33	1	3-2280624-3	POWER ON, OFF MODULE W/115 VAC INDICATOR LAMP
34	1	3-2280624-4	SCR MOTOR CONTROLLER, 115 VAC X 90 VDC, W/0.51 OHM HORSEPOWER RESISTOR, ASSEMBLED
35	1	3-2280624-5	CONTROL RELAY, 1CR, 2 POLE 115 VAC, 2CR, 3CR
36	1	3-2280624-6	START-UP TIMER 115/230VAC
37	1	3-2280624-7	PARTLOW TEMPERATURE CONTROLLER CONTROLLER, PROGRAMMED FOR M17R
38	1	3-2280624-8	FEED TRAY
39	1	3-2280624-9	RELAY SOCKET, LARGE

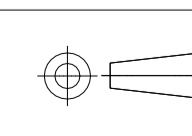
THIS DRAWING IS A CONTROLLED DOCUMENT.		DWN Kiran_Holal 12FEB2015	 TE Connectivity
DIMENSIONS: INCHES		CHK C Kerstetter 12FEB2015	
 0. PLC ± - 1. PLC ± - 2. PLC ± - 3. PLC ± - 4. PLC ± - ANGLES ± -		APPRO C Kerstetter 12FEB2015	NAME PRODUCT SPEC APPLICATION SPEC
MATERIAL	FINISH	WEIGHT	SIZE: A1 CAGE CODE: 00779 DRAWING NO: C=2280355 RESTRICTED TO: -
CUSTOMER DRAWING		SCALE: 1:1	SHEET 4 OF 4 REV E