

THIS DRAWING IS UNPUBLISHED. RELEASED FOR PUBLICATION, 19 .
 © COPYRIGHT 19 BY AMP INCORPORATED. ALL INTERNATIONAL RIGHTS RESERVED.

LOC	DIST	P	F	ZONE	LTR	DESCRIPTION	DATE	APPD
AJ	16				B	REDWN PER 0220-0159-95	3-10-95	JL

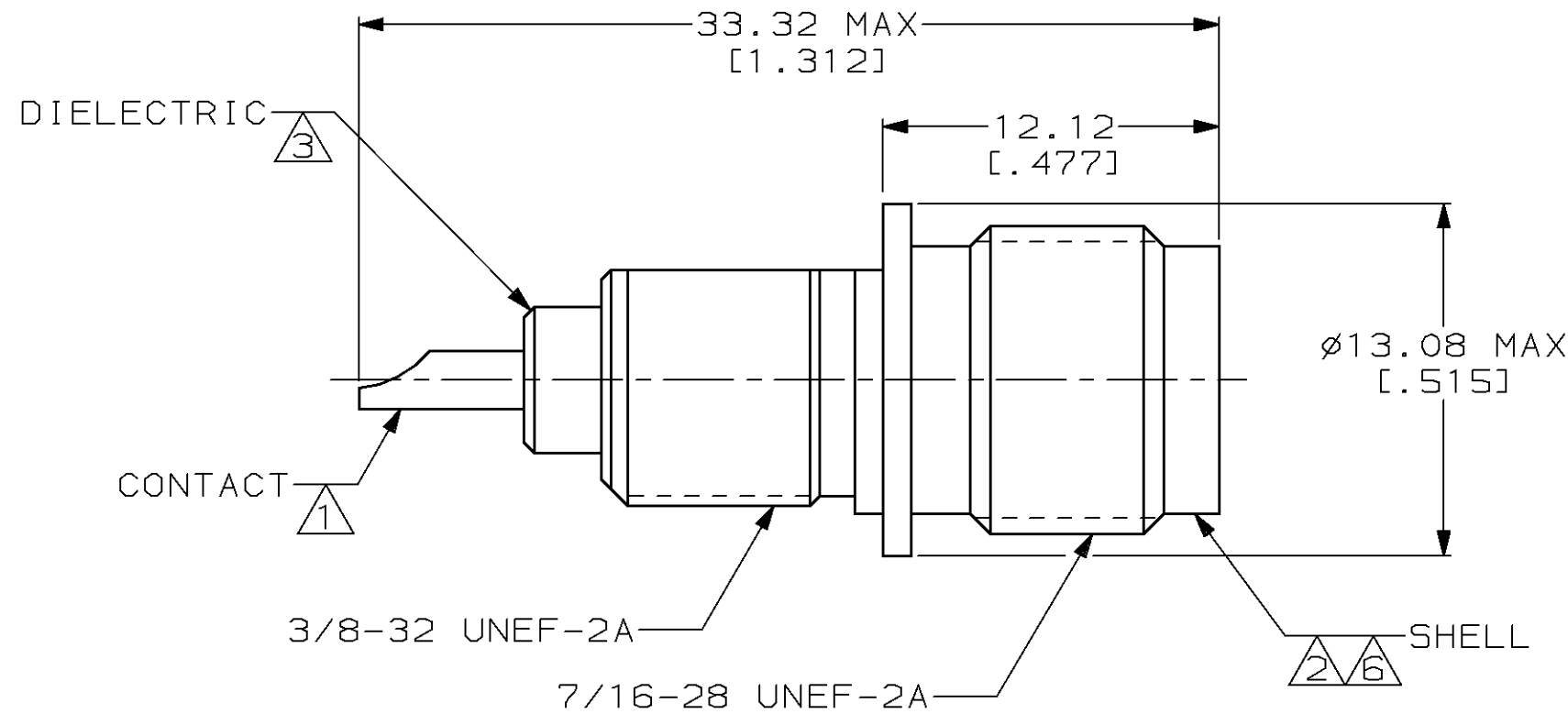

- ① PHOSPHOR BRONZE PER QQ-B-750.
- ② ZINC PER QQ-Z-363.
- ③ POLYESTER PBT PER MIL-M-24519.
- ④ SILVER PLATE PER QQ-S-365
2.54 μm [.000100] MINIMUM THICK.
- ⑤ TIN-LEAD PLATE PER ASTM-B-545
3.81 μm [.000150] MINIMUM THICK.
- ⑥ NICKEL PLATE PER QQ-N-290
3.81 μm [.000150] MINIMUM THICK.
- ⑦ GOLD PLATE PER MIL-G-45204,
0.76 μm [.000030] MINIMUM THICK.

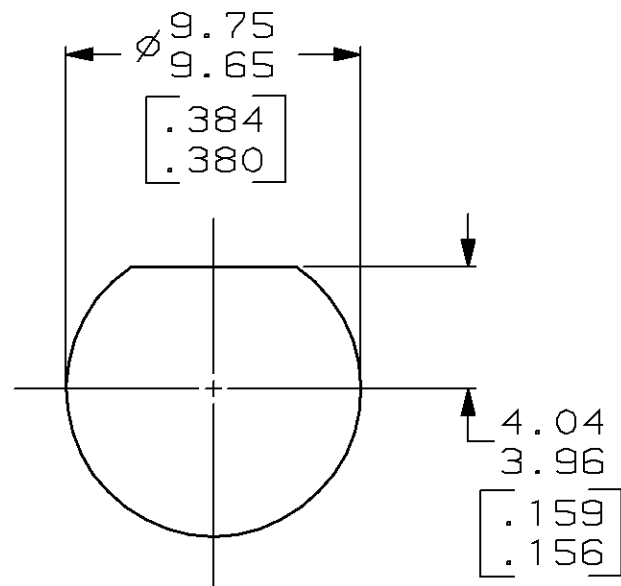

RECOMMENDED PANEL CUTOUT

THIS DRAWING IS A CONTROLLED DOCUMENT FOR AMP INCORPORATED. IT IS SUBJECT TO CHANGE AND THE CONTROLLING ENGINEERING ORGANIZATION SHOULD BE CONTACTED FOR THE LATEST REVISION.

④	227765-3
⑦	227765-2
⑤	227765-1
CONTACT FINISH	PART NO

DO NOT SCALE PRINT. UNLESS SPECIFIED DIMENSIONS IN mm [INCHES] TOLERANCES ON: 2 PLC DEC ± 0.25 [.010] 3 PLC DEC ± - ANGLES ± -	DR 3-10-95 J. LIPPERT	AMP AMP Incorporated Harrisburg, PA 17105-3608
	CHK 3-10-95 J. LIPPERT	
	APPD 3-10-95 J. LIPPERT	
	APPD 3-10-95 J. LIPPERT	
MATERIAL SEE NOTES 1 THRU 3	PRODUCT SPEC -	NAME SOLDER JACK ASSY, 50Ω TNC
FINISH SEE NOTES 4 THRU 7	APPLICATION SPEC -	SIZE B CAGE CODE 00779 DRAWING NO C -227765
	WEIGHT -	SCALE 4:1 SHEET 1 OF 1