

THIS DRAWING IS UNPUBLISHED. RELEASED FOR PUBLICATION
 © COPYRIGHT - By - ALL RIGHTS RESERVED.

REVISIONS				
P	LTR	DESCRIPTION	DATE	APVD
	A1	PER ECR-17-005987	10MAY2017	F.Y X.X

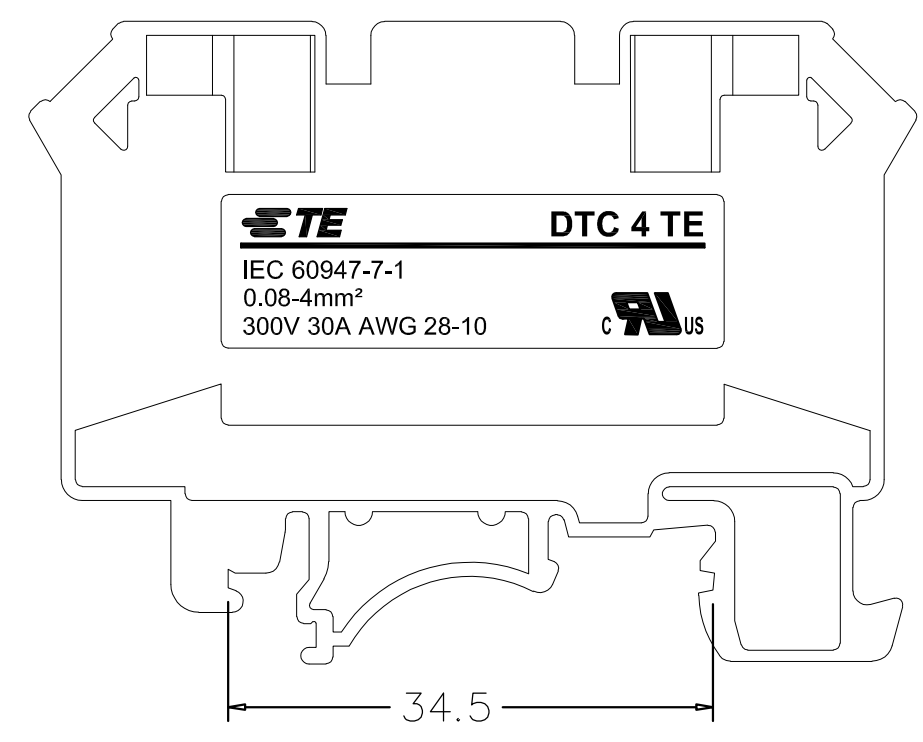
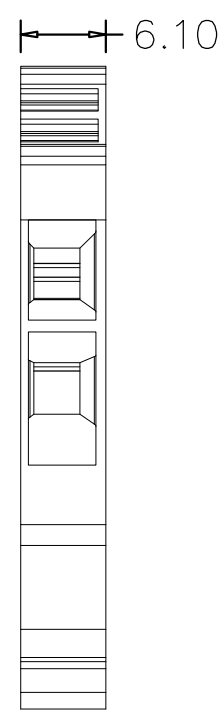
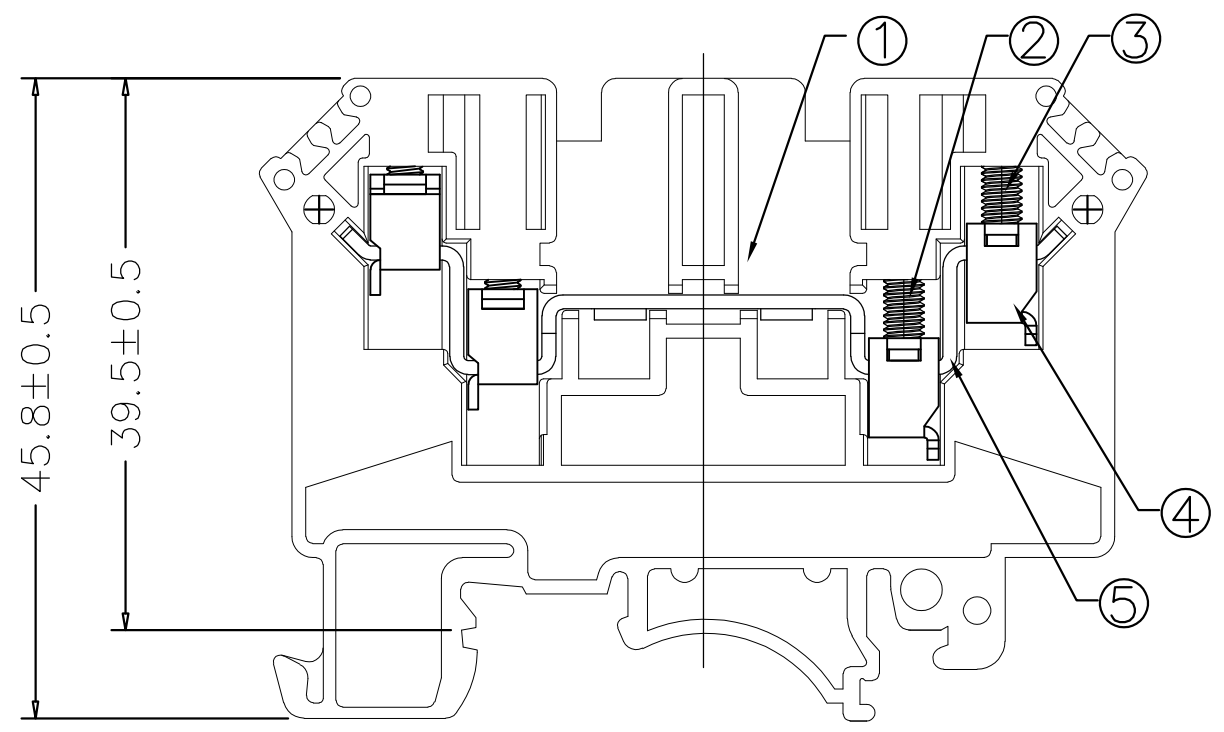
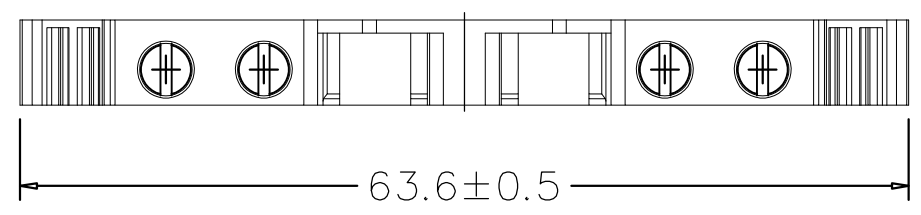

NOTES:

1. Material: See table
2. Rated current & voltage : (UL)30Amp 300V , (IEC)32Amp 630V
3. Impulse withstand voltage: 8KV
4. Screw Size & torque: M3, 5-6.2 lbs-in (0.56-0.7Nm)
5. Wire strip length: 8-10mm
6. Suitable wire size : (UL)28 - 10 AWG , (IEC)0.08-4mm²
7. Requirement for environmental substance must be compliance with ROHS and REACH.

ITEM	COMPONENTS	MATERIAL	Q'TY	PLATING
5	TERMINAL	COPPER	1	Tin Plated
4	CLAMP	STEEL	4	Zinc Plated
3	SCREW2	STEEL	2	Zinc Plated
2	SCREW1	STEEL	2	Zinc Plated
1	HOUSING	THERMOPLASTIC	1	

TE SERIES No.	PART NUMBER	COLOR
	2271682-5	BLACK
	2271682-4	ORANGE
	2271682-3	RED
	2271682-2	BLUE
	2271682-1	GRAY

THIS DRAWING IS A CONTROLLED DOCUMENT.		DWN FENCER YU 10MAY2017	TE Connectivity NAME 4MM ² WIRE SECTION 2 IN 2 OUT SCREW TYPE TERMINAL BLOCK	
DIMENSIONS: mm		CHK XIANG XU 10MAY2017		
TOLERANCES UNLESS OTHERWISE SPECIFIED:		APVD XIANG XU 10MAY2017	PRODUCT SPEC 108-137172	
0 PLC ± 0.50 1 PLC ± 0.40 2 PLC ± 0.30 3 PLC ± - 4 PLC ± - ANGLES ± 3°		APPLICATION SPEC 114-137172		RESTRICTED TO -
MATERIAL SEE TABLE		WEIGHT 12.71 g		SIZE A3
		CAGE CODE 00779		DRAWING NO C-2271682
CUSTOMER DRAWING		SCALE 1:1		SHEET 1 OF 1
				REV A1