

THIS DRAWING IS UNPUBLISHED. RELEASED FOR PUBLICATION
 © COPYRIGHT - By - ALL RIGHTS RESERVED.

REVISIONS					
P	LTR	DESCRIPTION	DATE	DWN	APVD
A		OFFICIAL VERSION RELEASE	18DEC2015	F.Y	X.X
A1		PER ECR-16-006247	16JUN2016	F.Y	X.X

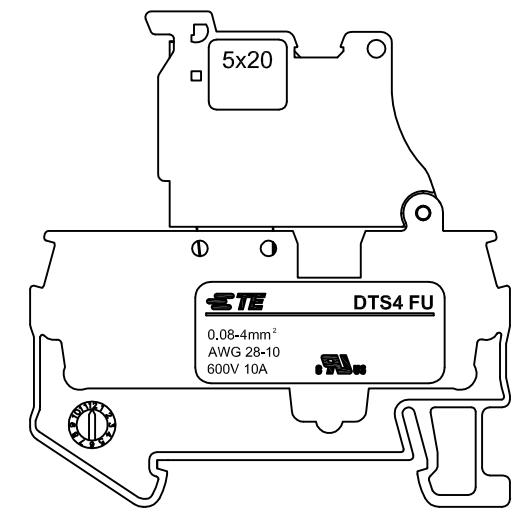
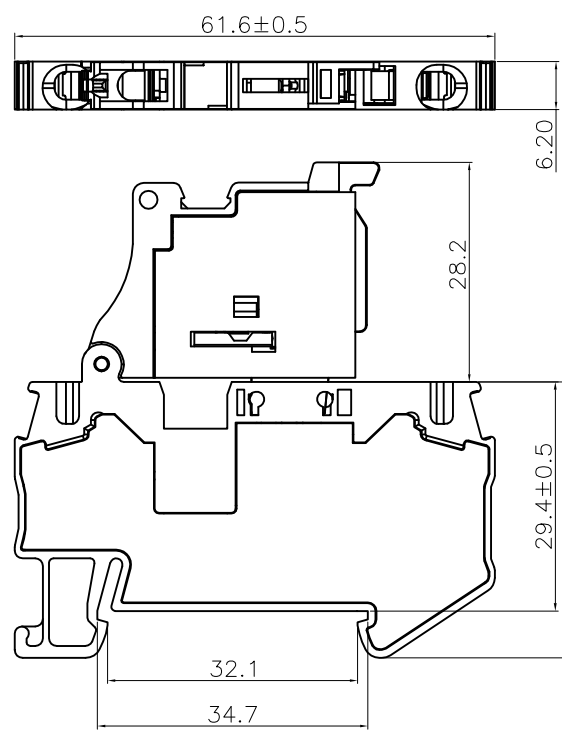
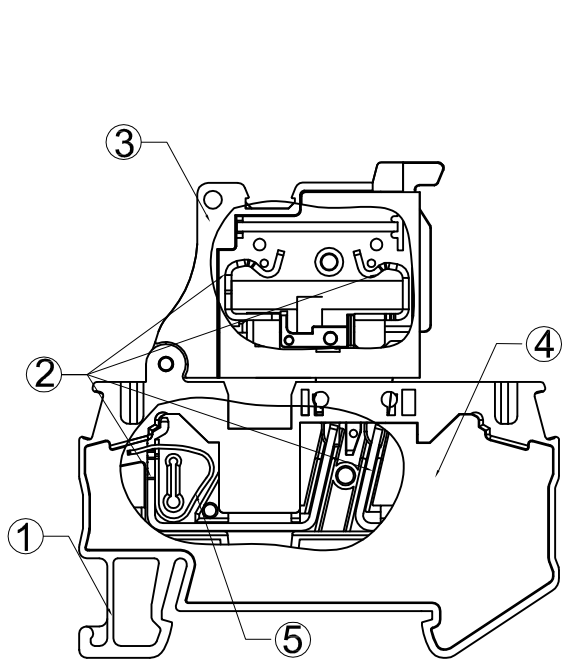

NOTE:

1. Material: See Table
2. Rated current & voltage : 10Amp(follow fuse) ,600V
3. Rated surge voltage: 6KV
4. Operation temperature : -40°C to +105°C
5. Wire strip length: 8mm -10mm
6. Suitable wire size : 28 - 10 AWG
7. Fuse:G/5x20
8. Requirement for environmental substance must be compliance with ROHS and REACH.
9. Recommended support rail requirements refer to 114 application specification.

ITEM	COMPONENTS	MATERIAL	Q'TY	PLATING
5	SPRING CLAMP	STAINLESS STEEL	2	
4	COVER	THERMOPLASTIC	1	
3	HOUSING 2	THERMOPLASTIC	1	
2	TERMINAL	COPPER	4	TIN PLATED
1	HOUSING 1	THERMOPLASTIC	1	

DTS4 FU	2271642-1	BLACK
TE SERIES No.	PART NUMBER	COLOR

THIS DRAWING IS A CONTROLLED DOCUMENT.		DWN FENCER YU 16JUN2016	TE Connectivity	
		CHK KOBBY ZHAO 16JUN2016		
APVD XIANG XU 16JUN2016		NAME 4mm~2 WIRE 1 IN 1 OUT SPRING CLAMP TERMINAL BLOCK ,FUSE TYPE WITHOUT LED		
DIMENSIONS: mm		PRODUCT SPEC 108-137138		
TOLERANCES UNLESS OTHERWISE SPECIFIED:		APPLICATION SPEC 114-137138		
0 PLC ± 0.50 1 PLC ± 0.40 2 PLC ± 0.30 3 PLC ± - 4 PLC ± - ANGLES ± 3°		SIZE A3	CAGE CODE 00779	DRAWING NO C=2271642
MATERIAL -		WEIGHT 14.35 g		RESTRICTED TO -
CUSTOMER DRAWING				
SCALE 1:1			SHEET 1 OF 1	REV A1