

LOC		DIST		REVISIONS			
P	LTN	DESCRIPTION	DATE	DMN	APVD		
C		REVISED PER ECO-14-000346	03JAN2014	DLB	RL		
D		REVISED PER ECO-14-005494	10APR2014	DLB	RL		
E		REVISED PER ECO-14-009260	13JUN2014	DLB	RL		
F		REVISED PER ECO-14-010435	11JUL2014	DLB	RL		

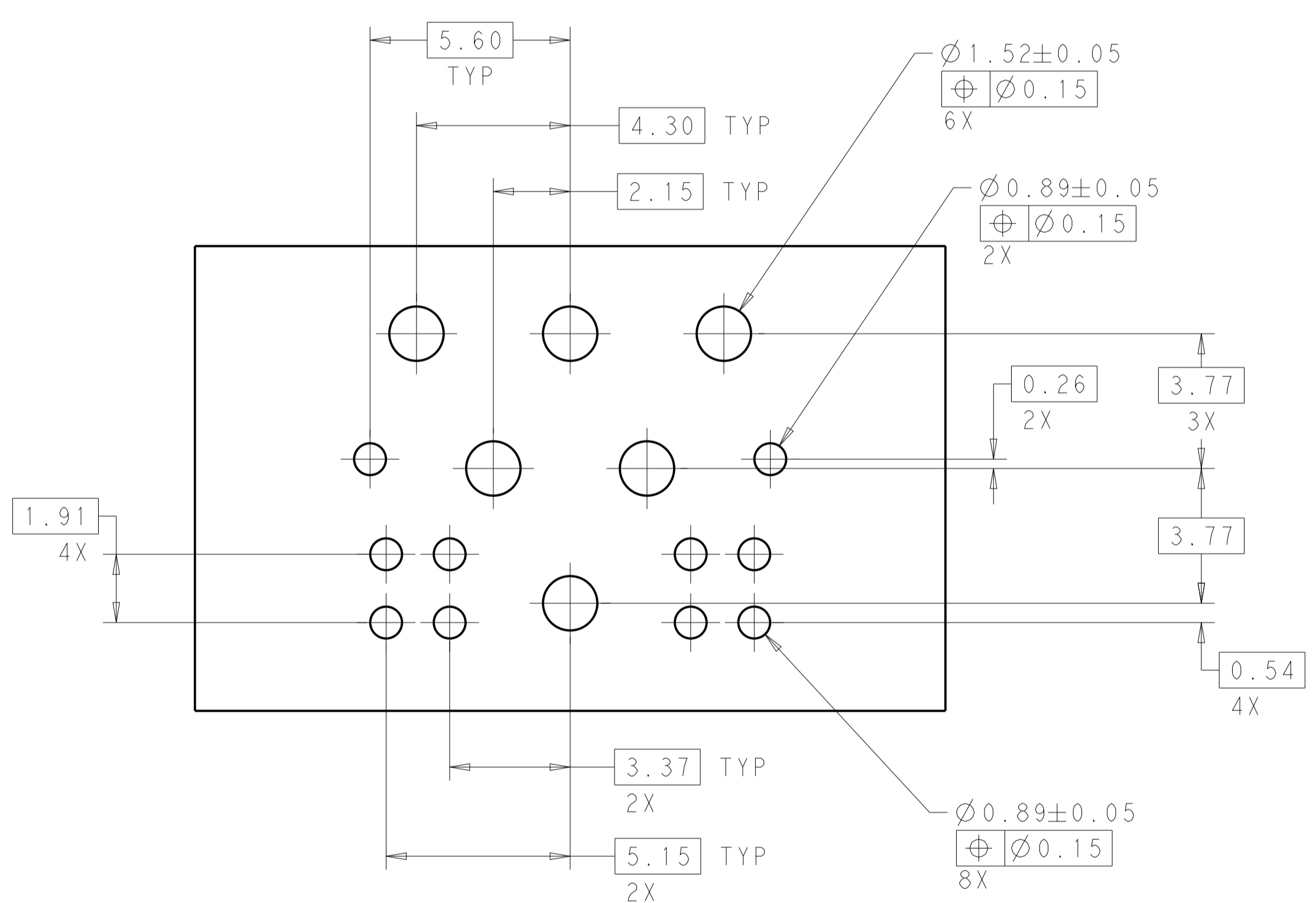

PCB LAYOUT

ASSEMBLY, SOCKET INSERT
RIGHT ANGLE

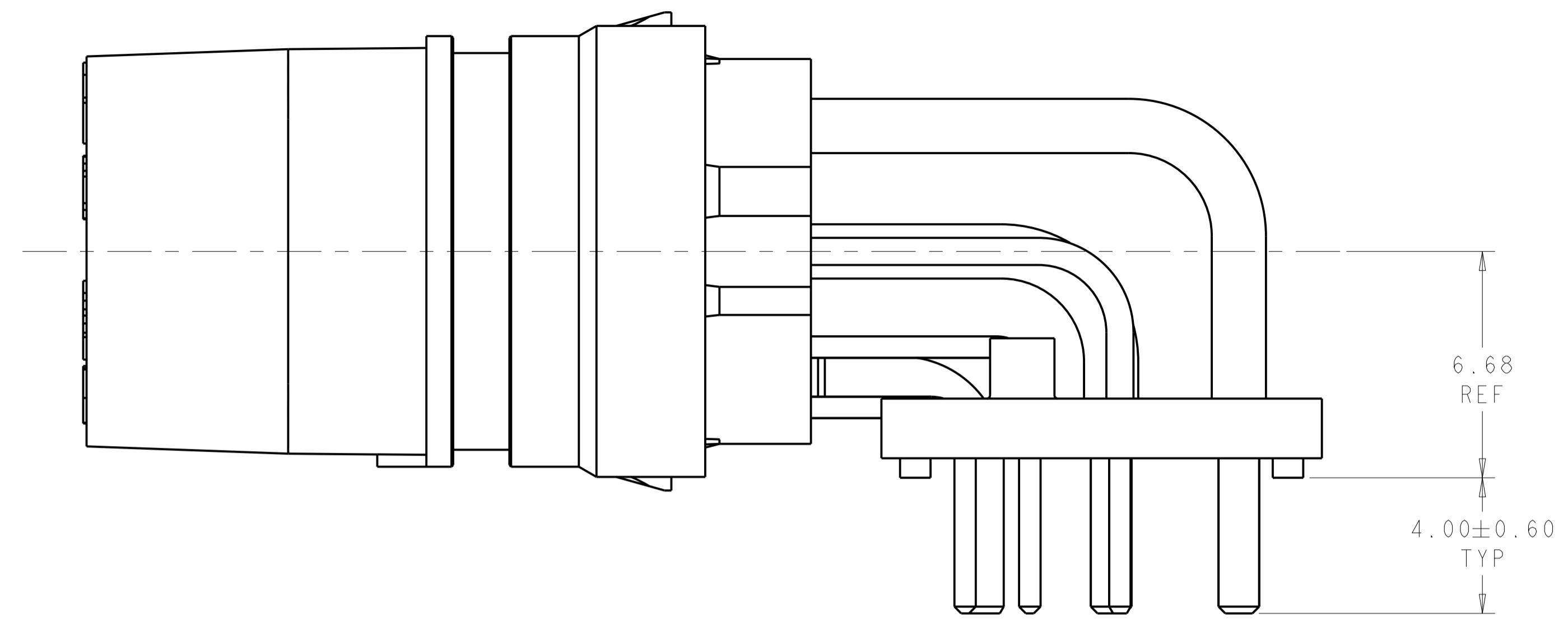
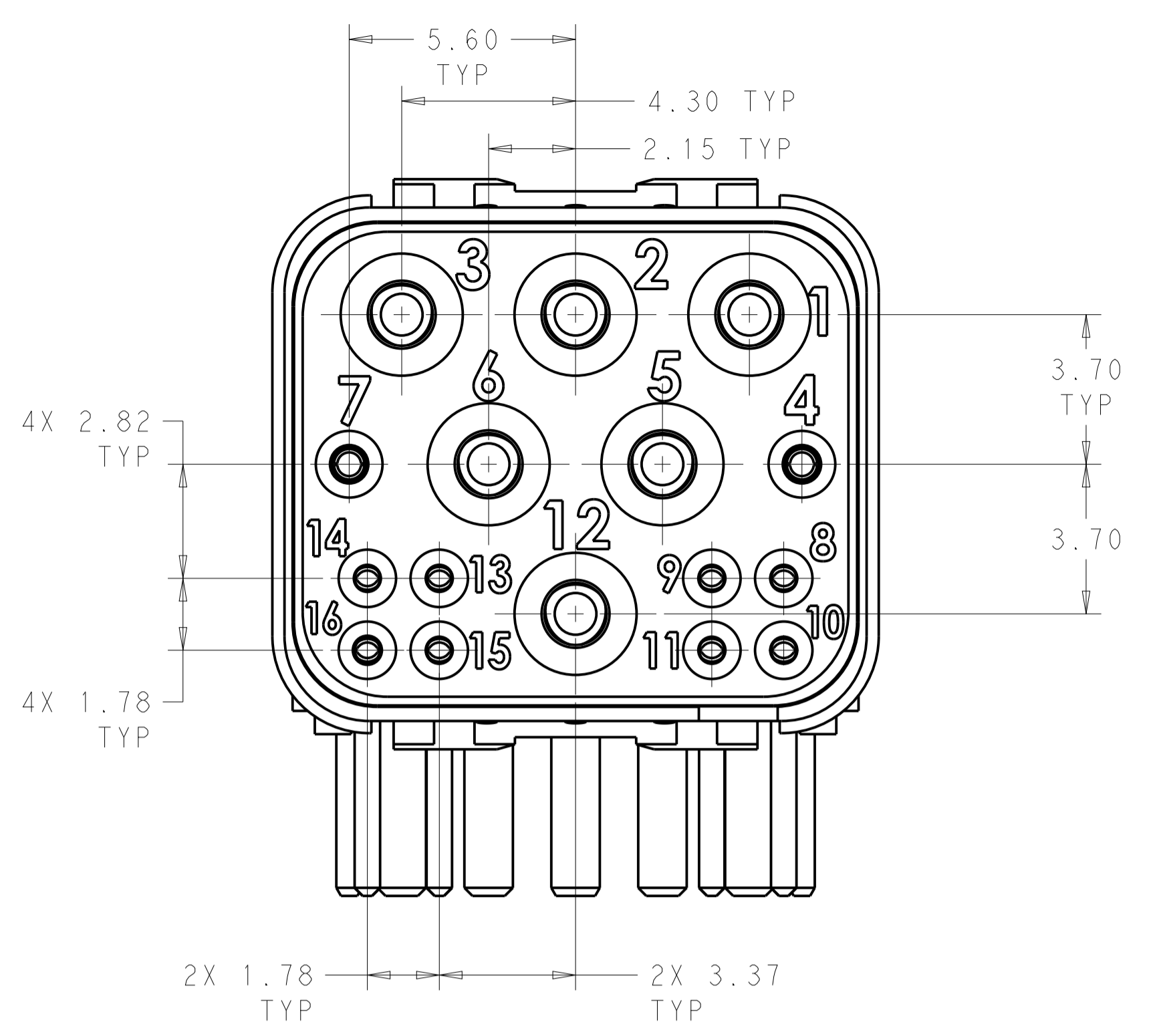
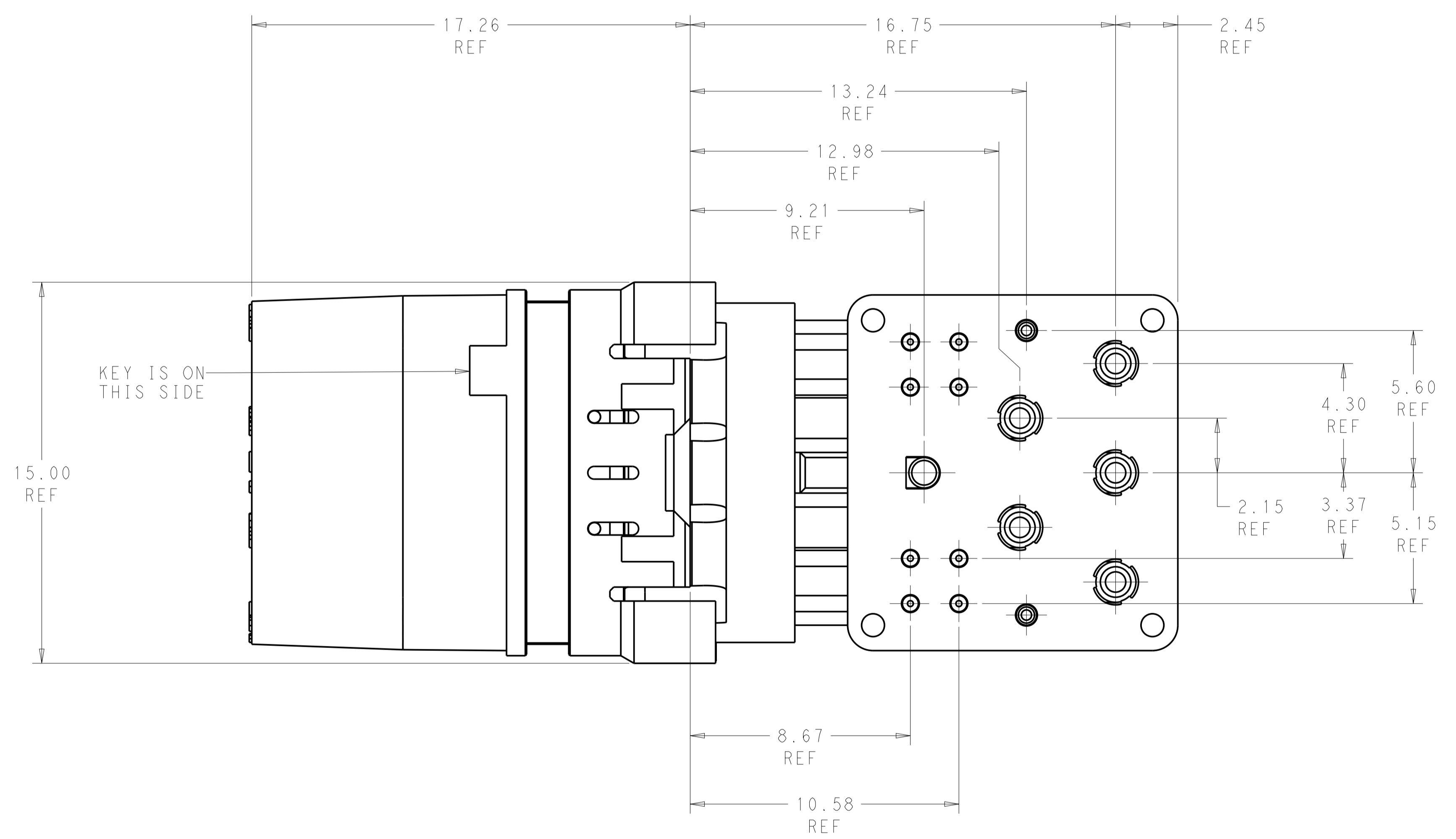

KEY IS ON THIS SIDE

PART NUMBER	FINISH ON EXTENDED TAILS	6 SIZE 16 TAIL DIAMETER	2 SIZE 22 TAIL DIAMETER	8 SIZE 24 TAIL DIAMETER
-1	GOLD	1.20 ± 0.03	0.64 ± 0.03	0.64 ± 0.03

SUPERCEDED BY 2286453-1	LOW COST STANDARD	2226413-2
	DESCRIPTION	PART NUMBER

CURRENT RATING			
SIZE	SIZE 16	SIZE 22	SIZE 24
CURRENT RATING (A)	15	5.4	3

THIS DRAWING IS A CONTROLLED DOCUMENT. DIMENSIONS: mm. TOLERANCES UNLESS OTHERWISE SPECIFIED: 0 PLC ±0.5, 1 PLC ±0.5, 2 PLC ±0.5, 3 PLC ±0.5, 4 PLC ±0.5, 5 PLC ±0.5, 6 PLC ±0.5, 7 PLC ±0.5, 8 PLC ±0.5, 9 PLC ±0.5, 10 PLC ±0.5, 11 PLC ±0.5, 12 PLC ±0.5, 13 PLC ±0.5, 14 PLC ±0.5, 15 PLC ±0.5, 16 PLC ±0.5. ANGLES: °. FINISH: . MATERIAL: .

DMN: D BROCKWAY 30MAY2013
CHK: R LUCENTE 30MAY2013
APVD: -

PRODUCT SPEC: -
APPLICATION SPEC: -
WEIGHT: -
CUSTOMER DRAWING

NAME: ASSEMBLY, SOCKET INSERT RIGHT ANGLE 16-02 MODULE, STANDARD PNB
SIZE: A1
CAGE CODE: 00779
DRAWING NO: 2226413
RESTRICTED TO: -

SCALE: 8:1 SHEET: 1 OF 1 REV: F