

P	LTR	DESCRIPTION	DATE	DWN	APVD
	A	Création. Diffusion 332491	15NOV2017	JFG	MV

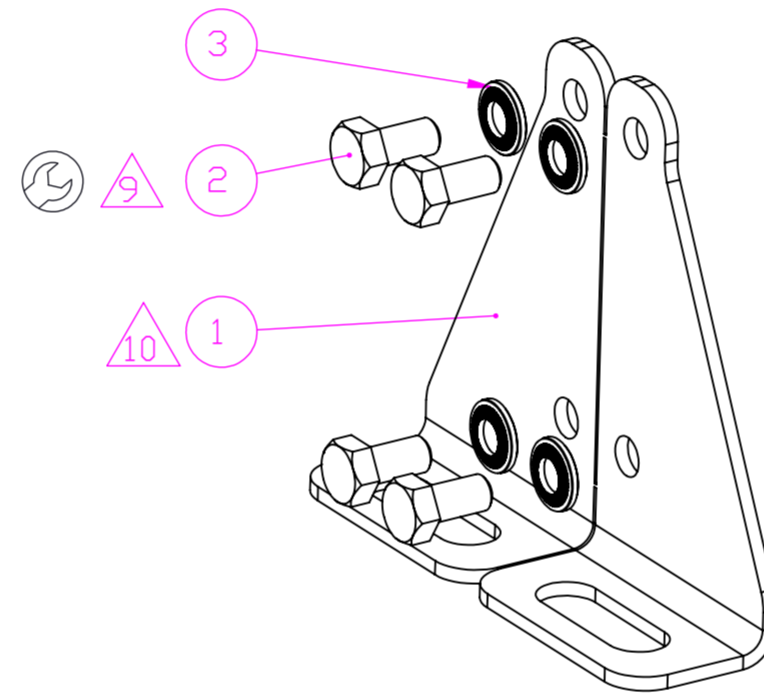
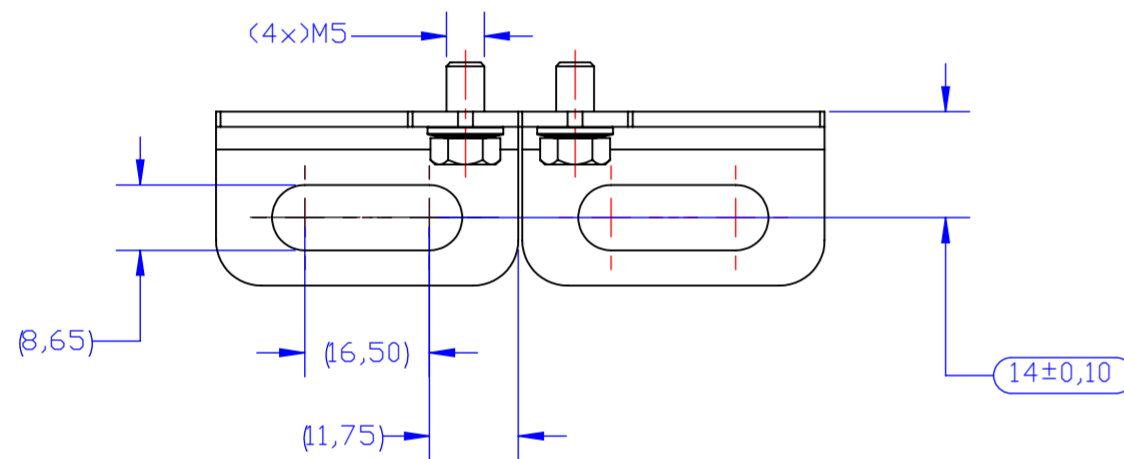
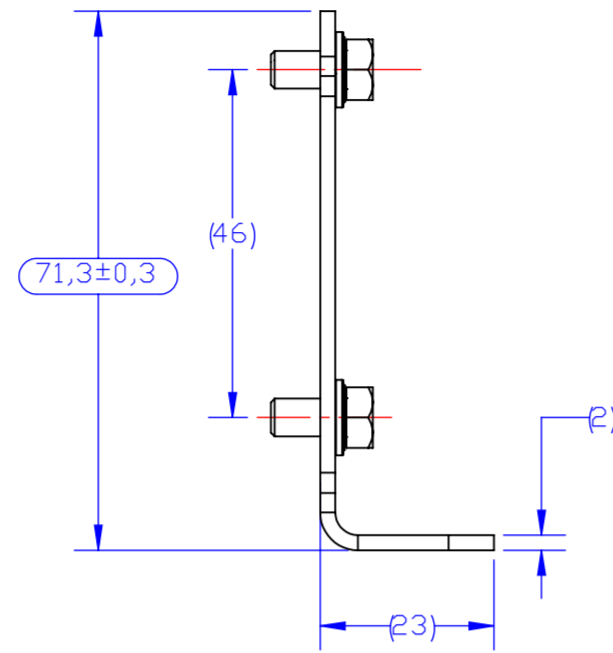
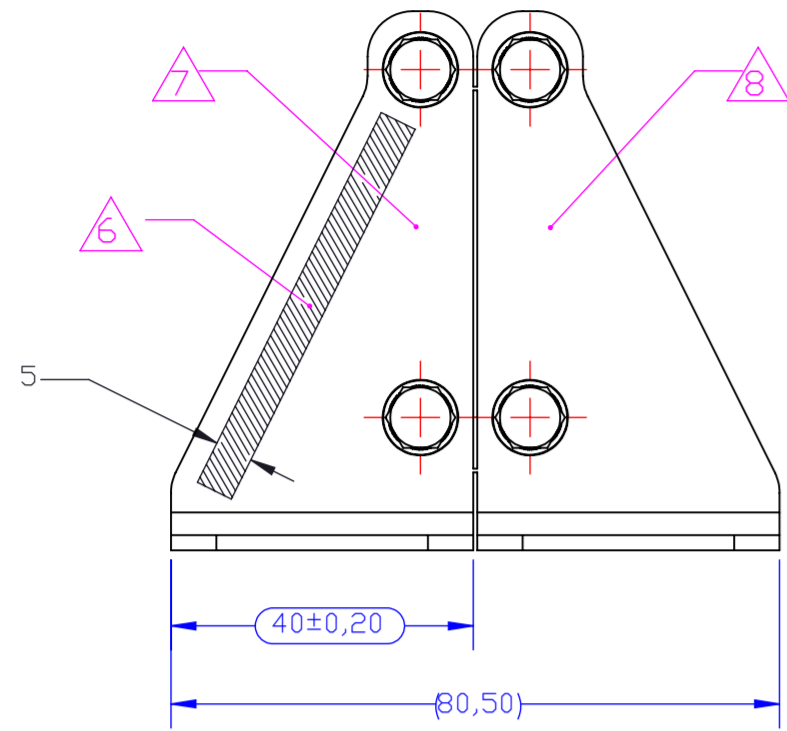

- 1 () : cotes pour information / dimensions for information
 () : cotes de controle / inspection dimensions
- 2 Instructions de mise en oeuvre à appliquer par le client
 Customer instructions to be applied by the customer
- 3 Spécification de packaging : 107-157006
 Packaging spec : 107-157006
- 4 Manuel client = 409-157000
 Customer manual = 409-157000
- 5 Le kit est composé de 2 tôles symétriques attachées entre elles et sa visserie
 The kit is composed of two symmetrical frames delivered linked together and its fasteners
- 6 Marquage lazer: TE + Ref com. + Année - Semaine
 Laser marking : TE + Com. ref. + Year - Week
- 7 Tôle de bridage pour le coté droit de lafiche
 Frame for the right side of the plug
- 8 Tôle de bridage pour le coté gauche de lafiche
 Frame for the left side of the plug
- 9 Fixer les tôles de bridage sur le corps de fiche avec les vis M5 en utilisant un frein filet fort.
 Set the clamp plates on the plug body with the M5 screws using a strong thread lock.
 Couple de serrage des vis
 Tightening torque of screws : 5 N.m
- 10 Les tôles de bridage sont livrées reliées entre elles, à séparer à la main par le client.
 Frames are delivered linked together, to be separated handly by the customer
- 11 Ce kit se monte sur la fiche FXP2RS-****-* (plan client C-212678).
 This kit monts on FXP2RS-****-* plug, (customer drawing C-212678).

-	-	-	Plastique Plastic	1	1	Y0000000000-EMB031	Sachet zip 150*180 Zip plastic bag 150*180	4
-	-	-	Inox Stainless steel	0,46	4	0436-0005-M-I	Rondelle contact étroite Narrow contact washer	3
-	-	-	Inox Stainless steel	3,06	4	HM05X10-I	Vis H M5x10 H screw M5x10	2
-	Passivation Passivation	FMME 3017	Inox Stainless steel	75,9	1	YT-KC-212868A-DY9C	Tôles de bridage pour fiche droite taille 2 Clamping frames for straight plug size 2	1
Observations Remarks	Protection Plating	Fiche matière Data sheet	Matière Material	Masse (g) Weight (g)	Nbr Qty	Codification Part number	Désignation Designation	REP Item

YS-KC-212988A-0000
PART NO

Référence commerciale / Commerciale reference : FXP-BS2

THIS DRAWING IS A CONTROLLED DOCUMENT.		DWN JF.GALIPAUD 15NOV2017	TE Connectivity	
		CHK M.BONNIN 15NOV2017		
DIMENSIONS: mm		APVD M.VIMARD 15NOV2017	NAME Kit de tôle de bridage pour fiche taille2 Clamping frames kit for plug size 2	
TOLERANCES UNLESS OTHERWISE SPECIFIED: 0 PLC -- 1 PLC -- 2 PLC -- 3 PLC -- 4 PLC -- ANGLES --		PRODUCT SPEC 108-157009	RESTRICTED TO	
MATERIAL -		APPLICATION SPEC 114-157007	SIZE A2	CAGE CODE -
FINISH -		WEIGHT 89,98 g	DRAWING NO C-212988	REV A
		CUSTOMER DRAWING	SCALE 1:1	SHEET 1 OF 1