

THIS DRAWING IS UNPUBLISHED. RELEASED FOR PUBLICATION
 © COPYRIGHT 2011 BY TYCO ELECTRONICS CORPORATION. ALL RIGHTS RESERVED.

LOC		DIST		REVISIONS				
P	LTR	DESCRIPTION			DATE	DWN	APVD	
	A	RELEASED			23NOV12	JL	WK	
	A1	REVISED PER ECN-23-221584			12JULY23	KH	SZ	

- NOTES:
- MATERIAL:
 - HOUSING: LCP WITH 30% G.F, UL94 V-0; COLOR: BLACK
 - CONTACT: BRASS
 - SHELL: STAINLESS STEEL
 - MYLAR: PET, YELLOW COLOR
 - FINISH:
 - CONTACT:
 - GOLD FLASH ON CONTACT AREA.
 - 2.54um[100u"] MIN. MATTE-TIN PLATING ON SOLDER TAIL.
 - 1.27um[50u"] MIN. NICKEL UNDERPLATING OVERALL.
 - SHELL:
 - 2.54um [100u"] MIN. NICKEL PLATING OVERALL.
 - 2.45um [100u"] MIN. CU UNDERPLATING OVERALL
 - REFLOW SOLDER CAPABLE TO 260°C PER TE SPEC. TEC-109-201, CONDITION B.
 - LOW HALOGEN SPEC:
 - CHLORINE(CI): 900PPM MAX
 - BROMINE(Br): 900PPM MAX
 - CI+Br: 1500PPM MAX

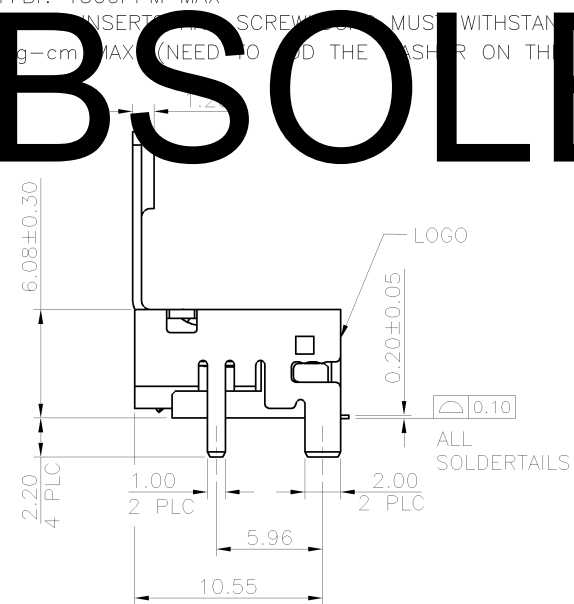
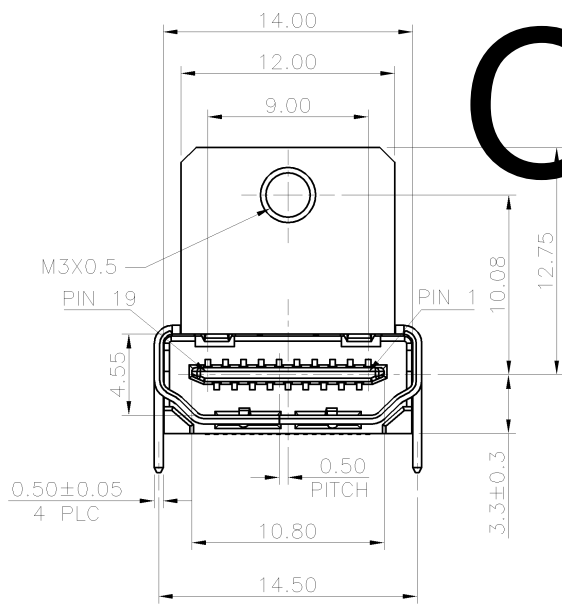
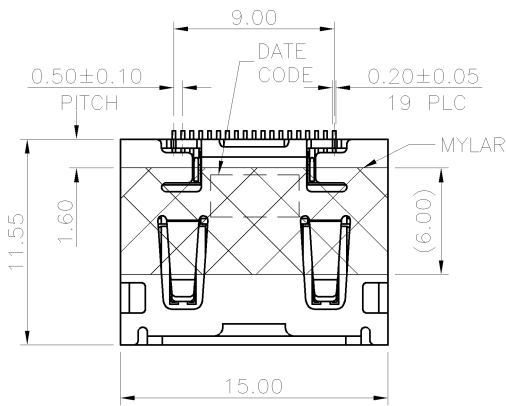

OBSOLETE

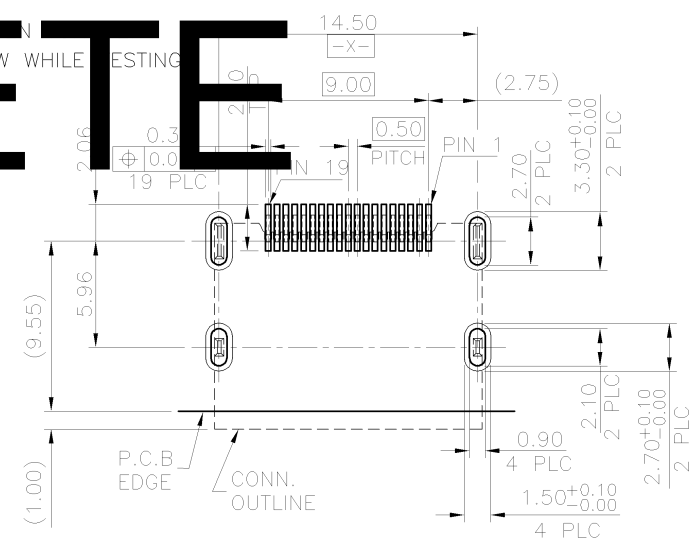

RECOMMENDED P.C.B LAYOUT <TOP VIEW>
 TOLERANCE: ±0.05; THICKNESS: 1.6mm

2041529-1
 PART NUMBER

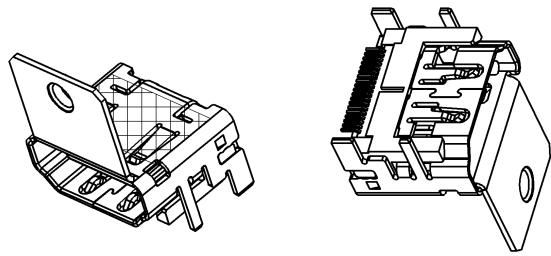

THIS DRAWING IS A CONTROLLED DOCUMENT.		DWN J. LAI 23NOV2012	TE Connectivity		
DIMENSIONS: mm		CHK S. CHIEN 23NOV2012			
TOLERANCES UNLESS OTHERWISE SPECIFIED:		APVD W. KODAMA 23NOV2012	NAME		
0 PLC ± - 1 PLC ± 0.3 2 PLC ± 0.2 3 PLC ± 0.15 4 PLC ± - ANGLES ± 3'		PRODUCT SPEC 108-57917	HDMI CONNECTOR, TYPE A, RECEPTACLE, RIGHT ANGLE, SMT		
MATERIAL SEE NOTE		APPLICATION SPEC	SIZE A3	CAGE CODE 00779	DRAWING NO C-2041529
FINISH SEE NOTE		WEIGHT 2.38 GRAMS	RESTRICTED TO		
		CUSTOMER DRAWING	SCALE	SHEET 1 of 2	REV A1

THIS DRAWING IS UNPUBLISHED. RELEASED FOR PUBLICATION
 © COPYRIGHT 2011 BY TYCO ELECTRONICS CORPORATION. ALL RIGHTS RESERVED.

LOC	DIST	REVISIONS					
DW		P	LTR	DESCRIPTION	DATE	DWN	APVD
				SEE SHEET 1.			

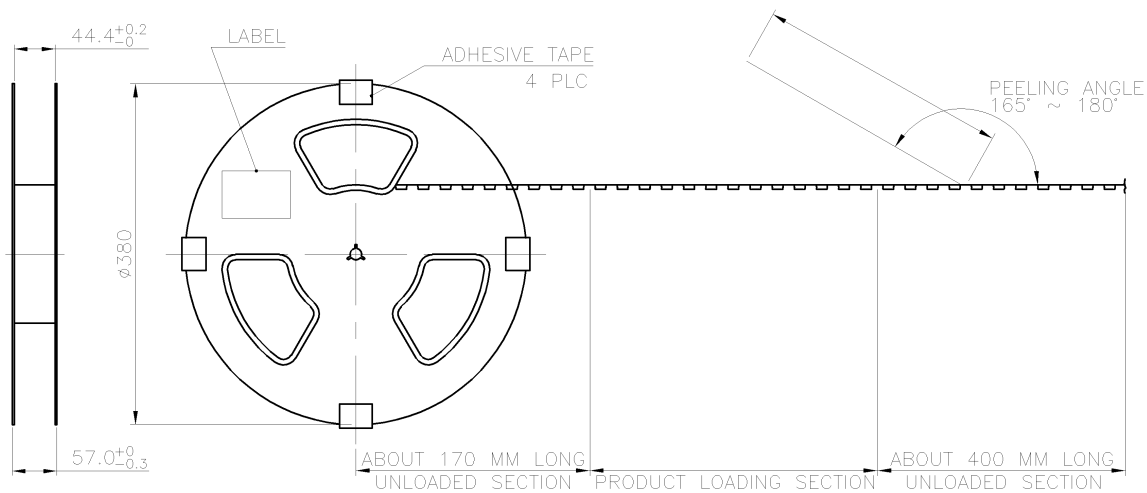

- NOTES :
- MATERIAL :
 COVER TAPE : PET, COLOR: TRANSPARENT
 CARRIER TAPE : POLYSTYRENES, COLOR: BLACK.
 REEL : POLYSTYRENES, COLOR: BLUE.
 BOX: CORRUGATED FIBER.
 BAG: PE, COLOR: TRANSPARENT.
 - PEELING RESISTANCE : 10gf~130gf
 - PEELING SPEED : 300mm/MINUTES

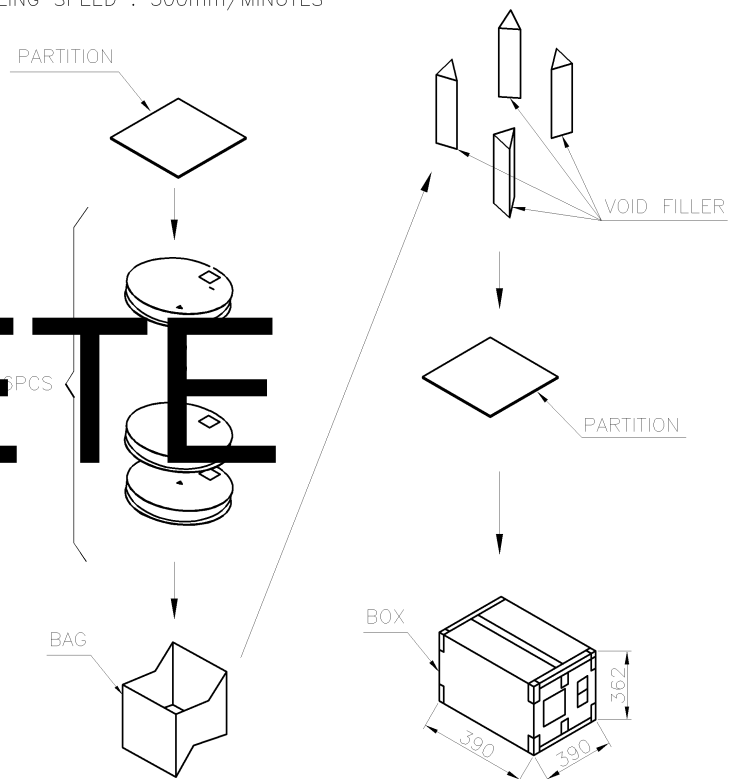

OBSELETE

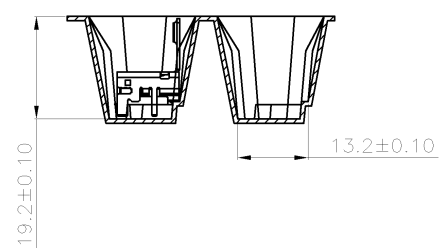
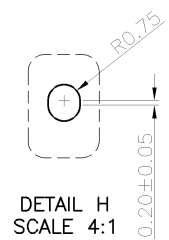
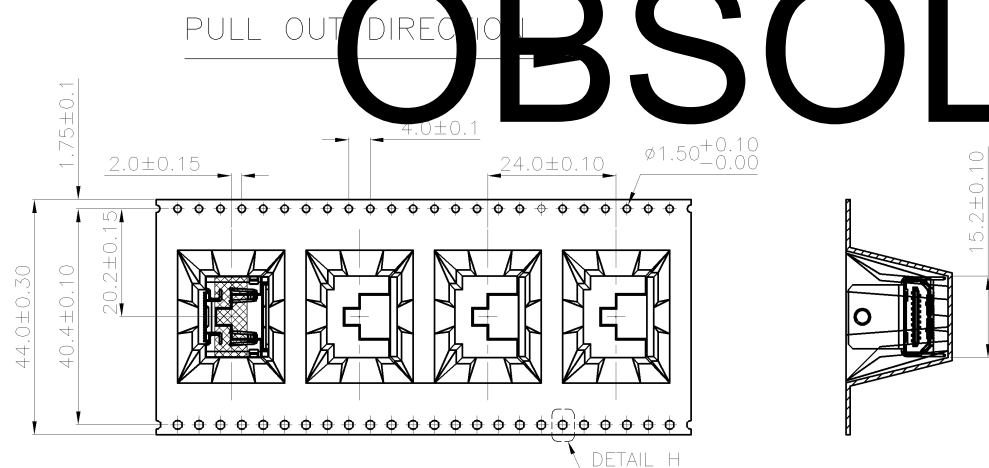

6.60 KG	2.45 KG	170 PCS	6 PCS	1020 PCS
GROSS WEIGHT	NET WEIGHT	PCS/REEL	REEL/BOX	PCS/BOX

THIS DRAWING IS A CONTROLLED DOCUMENT.		DWN	TE Connectivity		
DIMENSIONS: mm		CHK	NAME		
TOLERANCES UNLESS OTHERWISE SPECIFIED:		APVD	HDMI CONNECTOR, TYPE A, RECEPTACLE, RIGHT ANGLE, SMT		
0 PLC ±		PRODUCT SPEC	SIZE	CAGE CODE	DRAWING NO
1 PLC ±		APPLICATION SPEC	A3	00779	C=2041529
2 PLC ±		WEIGHT	RESTRICTED TO		
3 PLC ±		CUSTOMER DRAWING	SCALE	SHEET	REV
4 PLC ±				2 of 2	A1
ANGLES ±					
FINISH					