

© 1965 BY AMP INCORPORATED. ALL RIGHTS RESERVED. AMP PRODUCTS COVERED BY PATENTS AND/OR PATENTS PENDING. APPROVED PER GOVT CONTRACT NO.

REVISIONS				
SYM	ZONE	DESCRIPTION	DATE	APPROVAL
K		REV PER ECO 18-012801	CT 11-18	PD

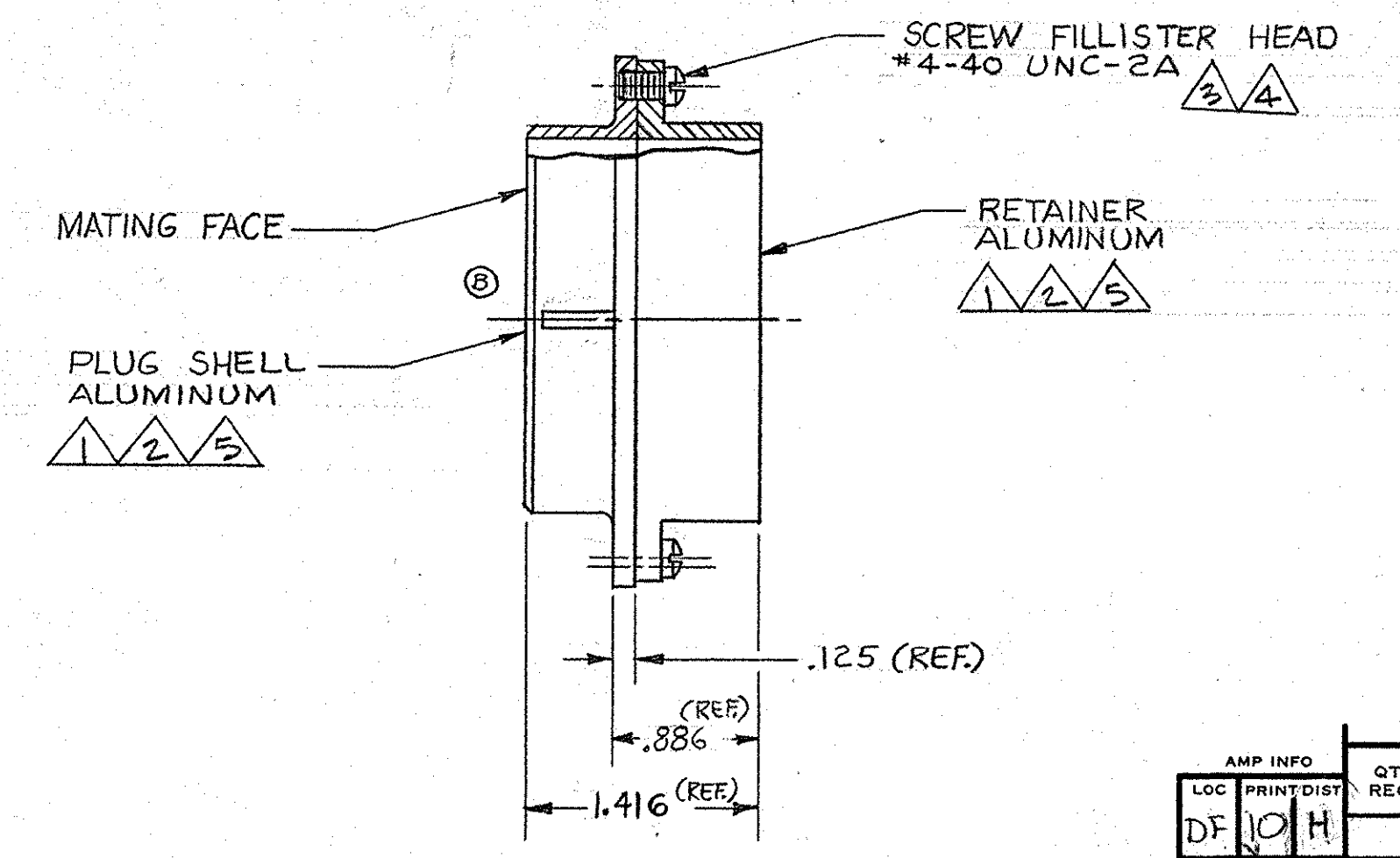
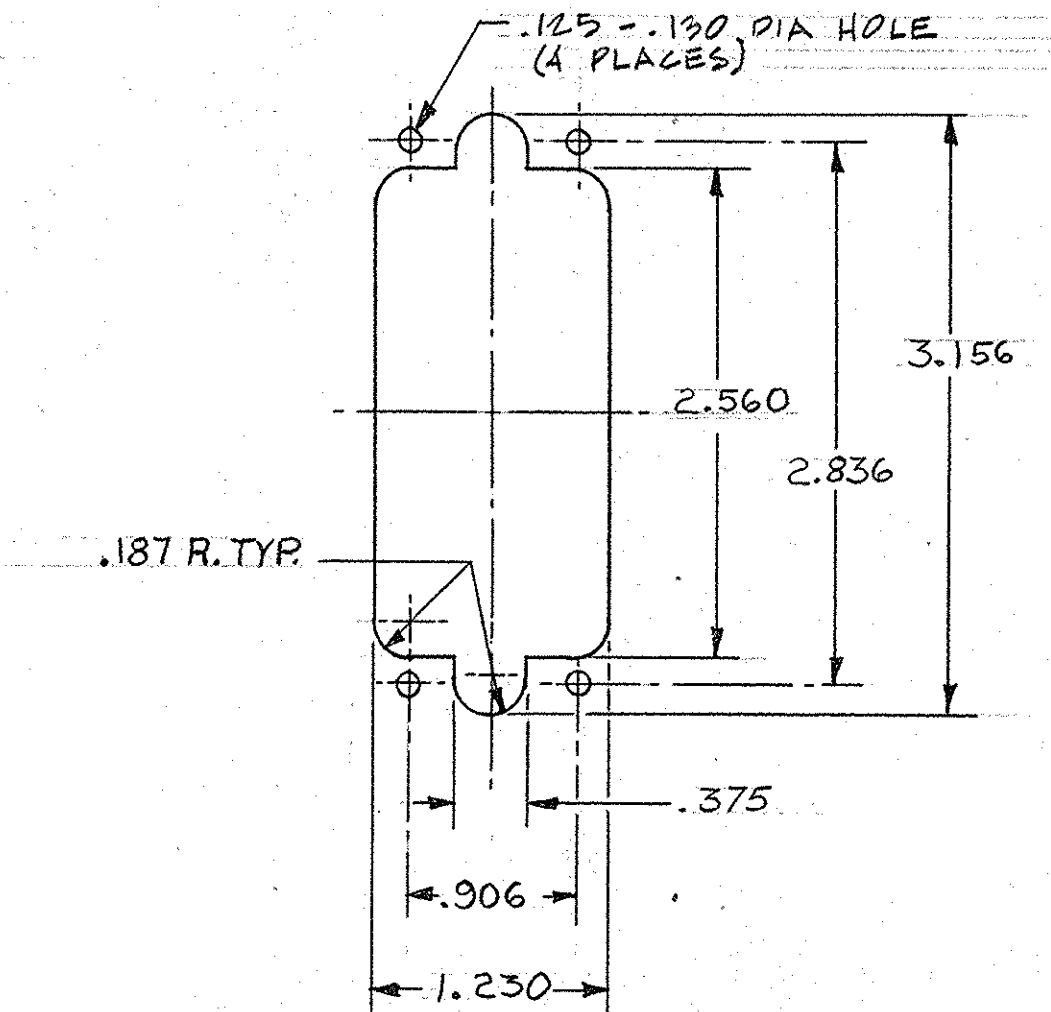
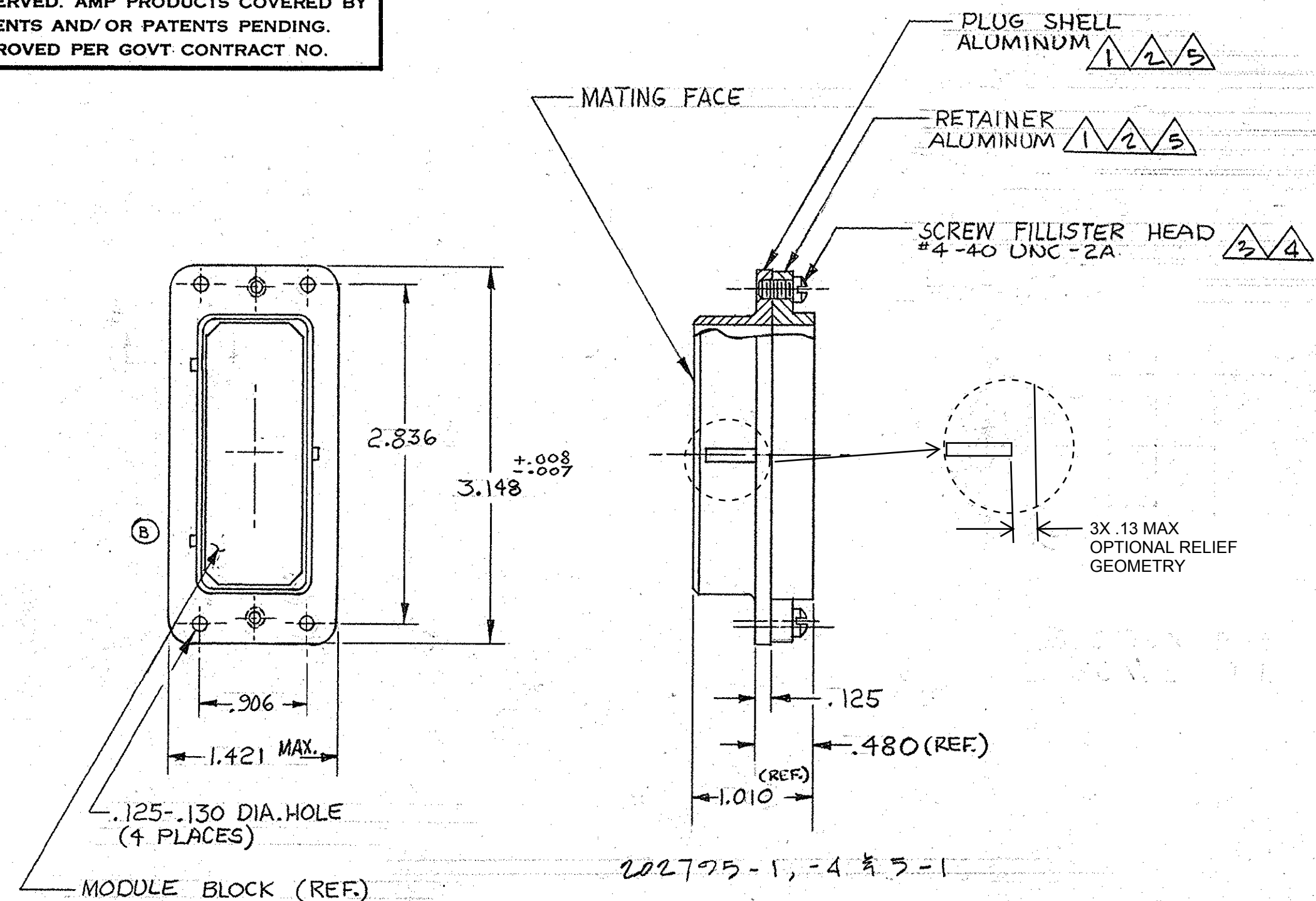

PANEL CUTOUT
SCALE: 1-1

- ① ZINC PLATE PER ASTM-B-633 TYPE II .000200-.000400 THK CLASS 3 COLORLESS SUPPLEMENTARY CHROMATE.
- ② ELECTROLESS NICKEL PLATE PER SAE-AMS-C-2607A .000400-.000800 THK (NO INTENTIONAL ADDITIONS OF LEAD OR CADMIUM PER DFE STANDARD 230-700).
- ③ ZINC PLATED COLD ROLLED STEEL.
- ④ PASSIVATED STAINLESS STEEL.
- ⑤ CADMIUM PLATE PER QQ-P-416 .000200-.000400 THK.

5-202795-2	FOR PINS	② ④	
5-202795-1	FOR SOCKETS	② ④	
202795-4	FOR SOCKETS	① ⑤	OBSOLETE
202795-3	FOR PINS	① ③	OBSOLETE
202795-2	FOR PINS	① ③	SUPERSEDED BY 5-202795-2
202795-1	FOR SOCKETS	① ③	SUPERSEDED BY 5-202795-1
PART NO.	ASSY TYPE	FINISH	

AMP INFO	QTY REQD	NOMENCLATURE OR DESCRIPTION	PART OR IDENTIFYING NO	LIST OF MATERIALS OR PARTS LIST	
LOC PRINT/DIST DF 10/H					
UNLESS OTHERWISE SPECIFIED DIMENSIONS ARE IN INCHES TOLERANCES ON		SIGNATURE		DATE	AMP INCORPORATED HARRISBURG, PENNSYLVANIA NAME PLUG ASSEMBLY, MODULE SERIES "G" (3 BLOCKS)
FRACTIONS	DECIMALS	ANGLES	DR <i>E. Benninger</i> 10-12-65 CHR <i>S. Steide</i> 11-9-65 DSGN ENGR <i>J. Williams</i> 11-9-65 APPR <i>R. B. Miller, Jr.</i> 11-9-65		
± --	± .005	± --	DSGN APPD OTHER APPD		
HEAT TREAT		FINISH		CODE IDENT NO 00779 SIZE D NUMBER 202795 REV K	
SEE CALL OUT		SEE CALL OUT		SCALE	WT CALC ACTUAL SHEET 1 of 1

CUSTOMER DRAWING