

THIS DRAWING IS UNPUBLISHED. RELEASED FOR PUBLICATION
 BY AMP INCORPORATED. ALL RIGHTS RESERVED.

LOC	DIST	REVISIONS					
		P	LTR	DESCRIPTION	DATE	DWN	APVD
BD	36	J		REDRAWN PER EC 0020-930-95	19 SEP 95	-	-
		K		OBSOLETE -1 PER EC 0020-492-95	27 OCT 95	CD	GS

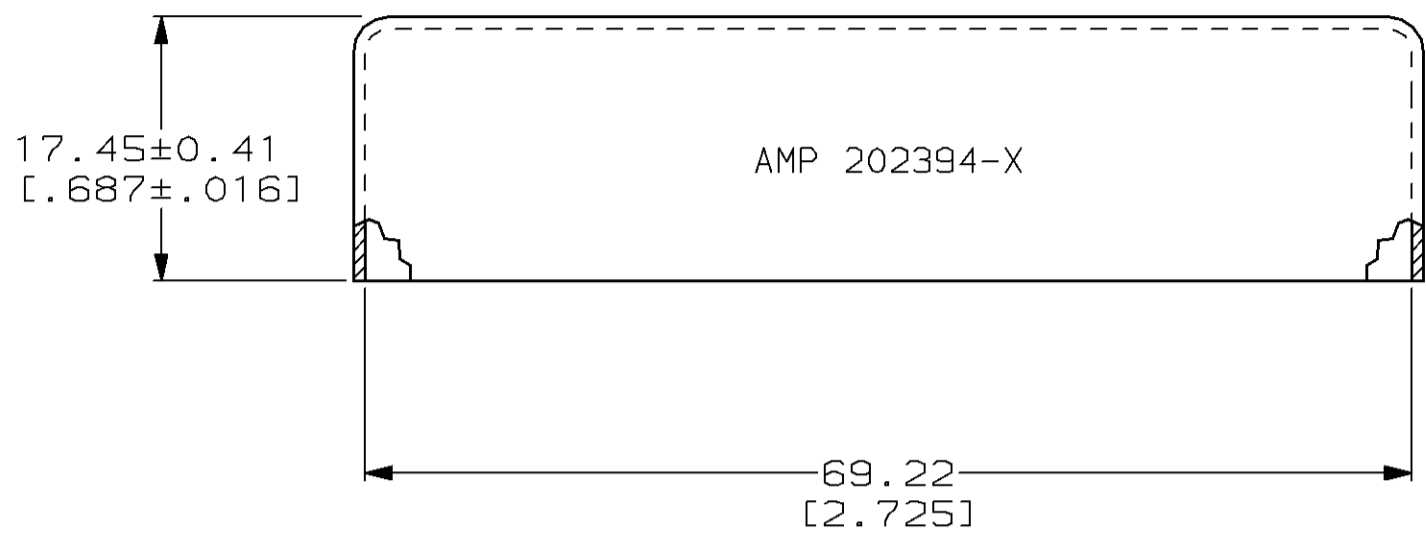

- ① 0.79 [.031] THICK ALUMINUM ALLOY.
- ② 0.79 [.031] THICK CARBON STEEL.
- ③ CLEAR IRIDITE.
- ④ 5.08µm [.000200] MIN NICKEL.

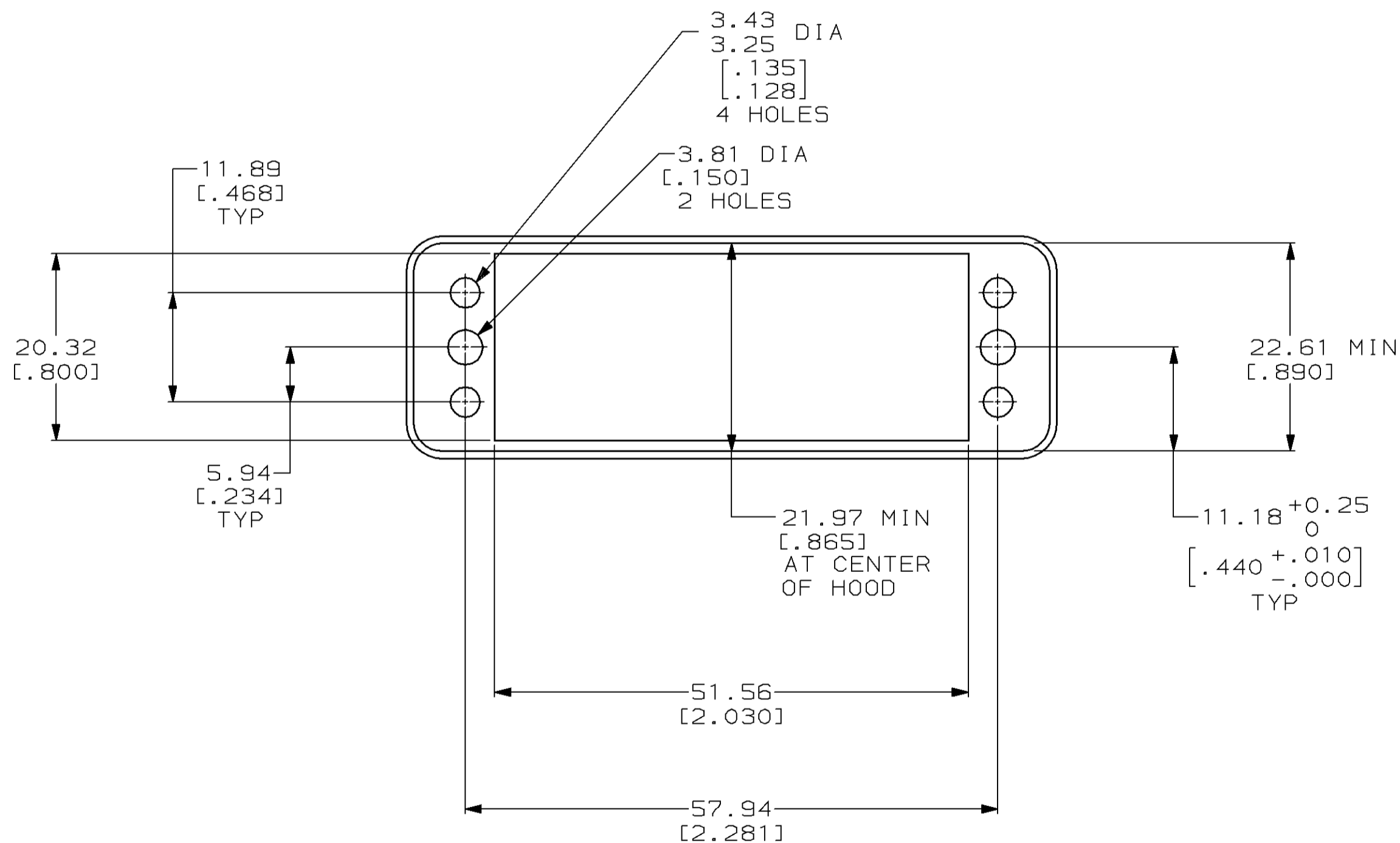

	④	②	202394-2
OBSOLETE	③	①	202394-1
	FINISH	MATERIAL	PART NUMBER

<small>THIS DRAWING IS A CONTROLLED DOCUMENT FOR AMP INCORPORATED. IT IS SUBJECT TO CHANGE AND THE CONTROLLING ENGINEERING ORGANIZATION SHOULD BE CONTACTED FOR THE LATEST REVISION.</small>		DWN C. DORWART 19 SEP 95 CHK R. STONE 25 SEP 95 APVD G. STEINHAUER 04 OCT 95 PRODUCT SPEC - APPLICATION SPEC - WEIGHT - CUSTOMER DRAWING	AMP Incorporated Harrisburg, PA 17105-3608 PIN HOOD, 50 PLACE, INTERNAL, M SERIES SIZE A2 CAGE CODE 00779 DRAWING NO C=202394 SCALE 2:1 SHEET 1 OF 1 REV K
DIMENSIONS: mm [INCHES]	TOLERANCES UNLESS OTHERWISE SPECIFIED: 0 PLC ±- 1 PLC ±- 2 PLC ±0.13 [.005] 3 PLC ±- 4 PLC ±- ANGLES ±- FINISH SEE TABLE	MATERIAL SEE TABLE	