

P	LTR	DESCRIPTION	DATE	DWN	APVD
	A	ECO-20-012219	11SEP2020	GK	DR

 Listed	 Certified
22-16 AWG SOLID OR STRANDED	22-16 AWG SOLID OR STRANDED

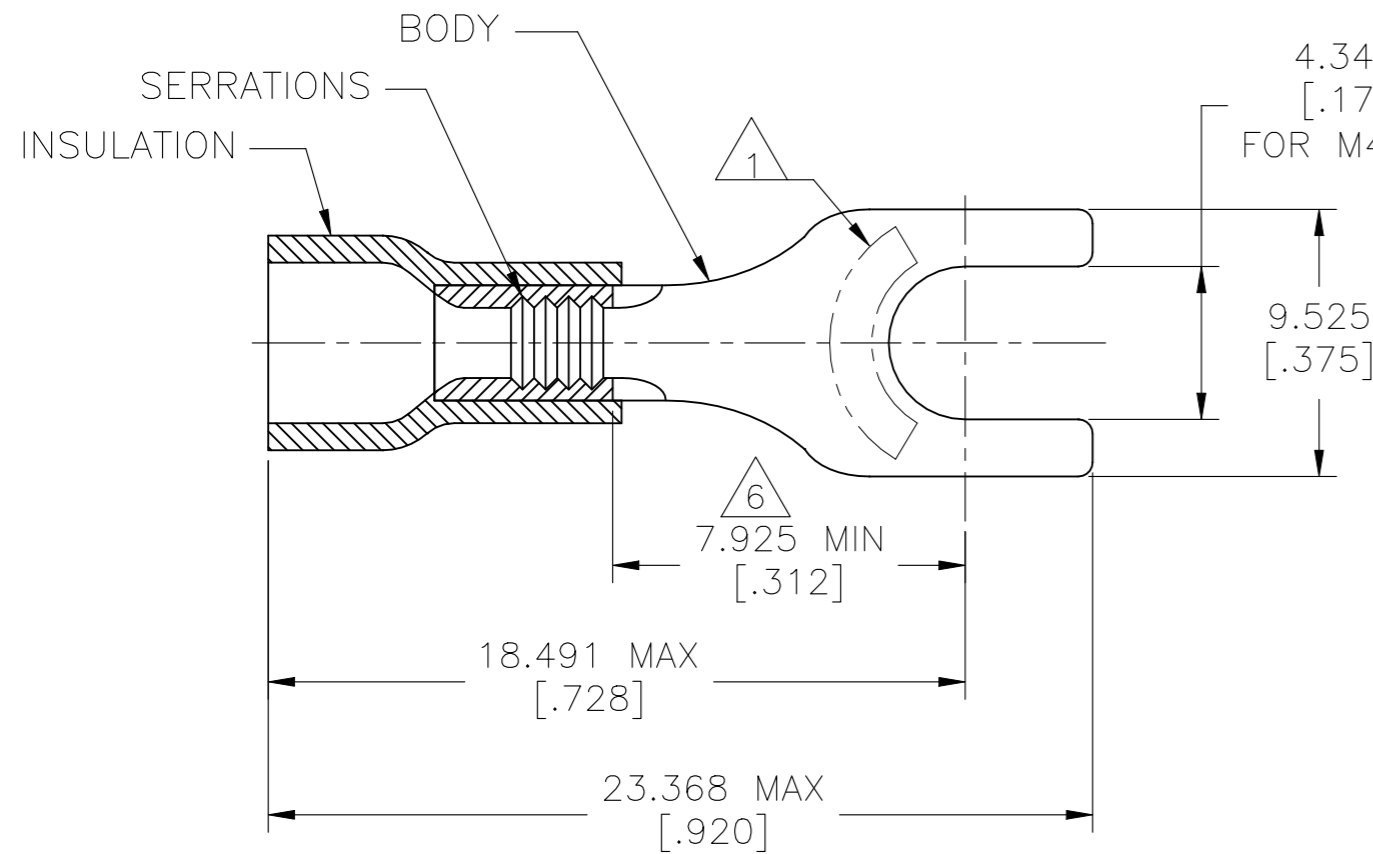

- 1 STAMP AMP 22-18* APPROX AS SHOWN
WIRE RANGE IS 22 - 16 AWG
- 2. WIRE INSULATION DIAMETER: $\phi 2.667 - 3.556$ [$\phi .105-.140$]
- 3. BODY MATERIAL THK: 0.787 ± 0.051 [$.031 \pm .002$]
- 4 MATERIAL: BODY - CU PER ASTM B152
INSULATION - PVC
- 5 FINISH: BODY - TIN PLATE 0.00254 [$.000100$] MIN EXT THK PER ASTM B545
INSULATION COLOR - RED
- 6 APPLIES FROM EDGE OF METAL WIRE BARREL TO CENTER OF STUD HOLE

100	SD015-040-V	1SET131003R0000	34155
QTY	DESIGNATION	ENTRELEC PN	TE PN

MAX RECOMMENDED OPERATING TEMPERATURE: 105°C [221°F] VOLTAGE RATING: 600V MAX (1000V FIXTURE OR SIGN) CIRCULAR MIL AREA: 0.26-1.65mm²[509-3260] SOLID OR STRANDED	THIS DRAWING IS A CONTROLLED DOCUMENT.		DWN 11SEP2020 GOPALAKRISHNA HV CHK 11SEP2020 ROHDE DANIEL F APVD 11SEP2020 ROHDE DANIEL F		ENTRELEC Electrical Solutions NAME TERMINAL, SPADE, PLASTI-GRIP, WIRE SIZE: 22-16 AWG			
	DIMENSIONS: mm [INCHES]	TOLERANCES UNLESS OTHERWISE SPECIFIED: 0 PLC ± - 1 PLC ± - 2 PLC ± - 3 PLC ± 0.127 [.005] 4 PLC ± - ANGLES ± -	PRODUCT SPEC UL 486A-B APPLICATION SPEC 114-2161					
	MATERIAL - 4	FINISH - 5	WEIGHT CUSTOMER DRAWING		SCALE 6:1	SHEET 1 OF 1	REV A	