

| P | LTR | DESCRIPTION   | DATE      | DWN | APVD |
|---|-----|---------------|-----------|-----|------|
|   | A   | ECO-20-012219 | 11SEP2020 | GK  | DR   |

|  |   |
|--|---|
|  Listed |  Certified |
| 22-16 AWG<br>SOLID OR STRANDED   | 22-16 AWG<br>SOLID OR STRANDED  |

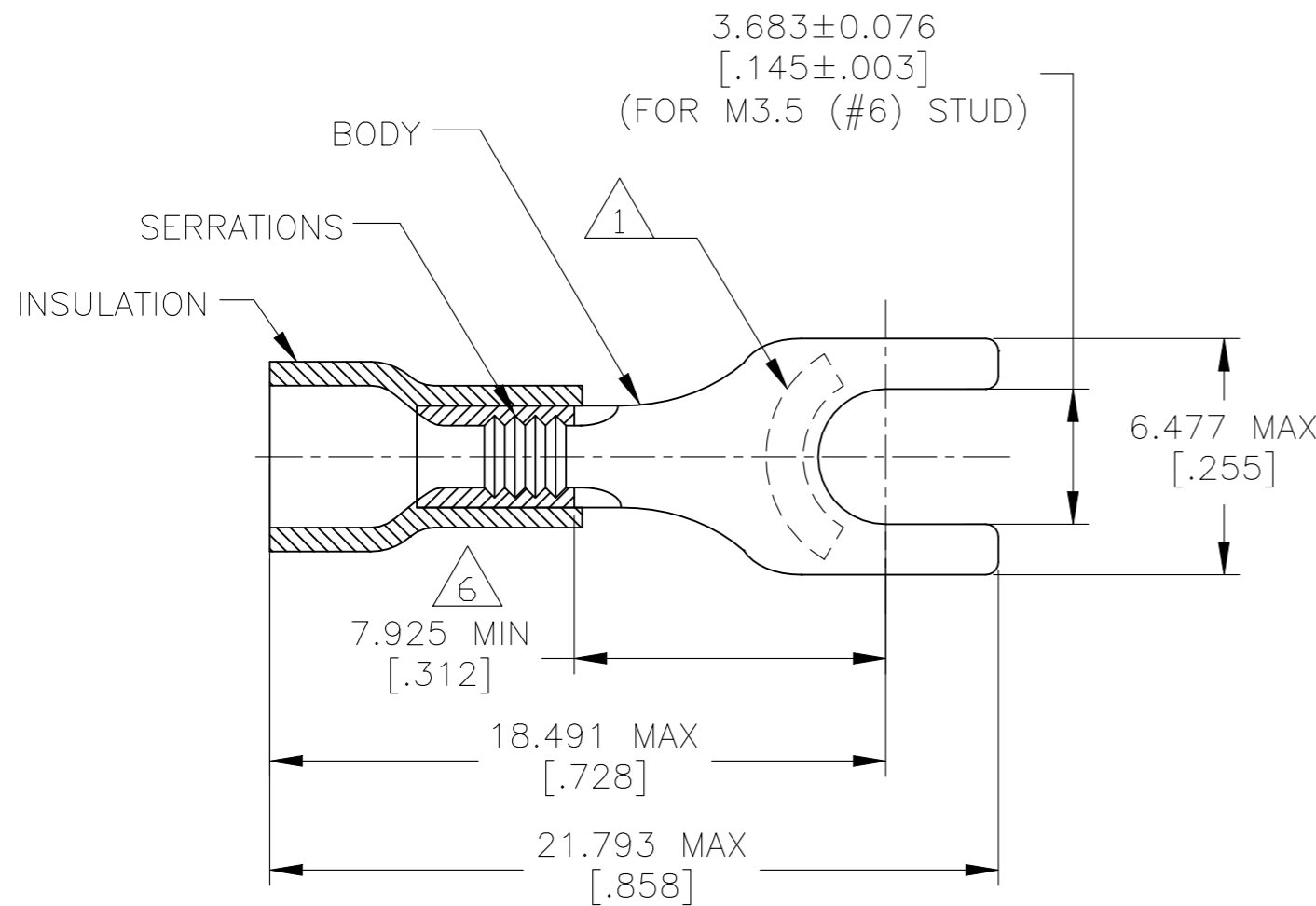

- 1 STAMP AMP 22-18\* APPROX AS SHOWN  
WIRE RANGE IS 22 - 16 AWG
- 2. WIRE INSULATION DIAMETER:  $\phi 2.667 - 3.556$  [ $\phi .105-.140$ ]
- 3. BODY MATERIAL THK:  $0.787 \pm 0.051$  [ $.031 \pm .002$ ]
- 4 MATERIAL: BODY - CU PER ASTM B152  
INSULATION - PVC
- 5 FINISH: BODY - TIN PLATE  $0.00254$  [ $.000100$ ] MIN EXT THK PER ASTM B545  
INSULATION COLOR - RED
- 6 APPLIES FROM EDGE OF METAL WIRE BARREL TO CENTER OF STUD HOLE

|     |             |                 |        |
|-----|-------------|-----------------|--------|
| 100 | SD015-035-V | 1SET131002R0000 | 327043 |
| QTY | DESIGNATION | ENTRELEC PN     | TE PN  |

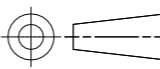
|   |   |   |                                   |   |              |                   |               |
|---|---|---|-----------------------------------|---|--------------|-------------------|---------------|
| MAX RECOMMENDED OPERATING TEMPERATURE:<br>105°C [221°F]<br><br>VOLTAGE RATING:<br>600V MAX<br>(1000V FIXTURE OR SIGN)<br><br>CIRCULAR MIL AREA:<br>0.26-1.65mm² [509-3260]<br>SOLID OR STRANDED | THIS DRAWING IS A CONTROLLED DOCUMENT.  |   | DWN 11SEP2020<br>GOPALAKRISHNA HV | <b>ENTRELEC</b><br>Electrical Solutions |              |                   |               |
|   | DIMENSIONS:<br>mm [INCHES]  | TOLERANCES UNLESS OTHERWISE SPECIFIED:  | CHK 11SEP2020<br>ROHDE DANIEL F   |   |              |                   | NAME          |
|   |  | 0 PLC ± -<br>1 PLC ± -<br>2 PLC ± -<br>3 PLC ± 0.127[.005]<br>4 PLC ± -<br>ANGLES ± - | APVD 11SEP2020<br>ROHDE DANIEL F  | PRODUCT SPEC                            |              |                   |               |
|   | MATERIAL  | FINISH  |                                   | APPLICATION SPEC                        |              |                   |               |
| - 4   | - 5   |   | UL 486A-B                         | SIZE                                    | CAGE CODE    | DRAWING NO        | RESTRICTED TO |
|   |   |   | 114-2161                          | A3                                      | 00779        | C-1SET131002R0000 | -             |
| CUSTOMER DRAWING  |   |   | SCALE 6:1                         |   | SHEET 1 OF 1 | REV A             |               |