

P	LTR	DESCRIPTION	DATE	DWN	APVD
	A	ECO-20-012219	11SEP2020	GK	DR

 Listed	 Certified
16-14 AWG SOLID OR STRANDED	16-14 AWG SOLID OR STRANDED

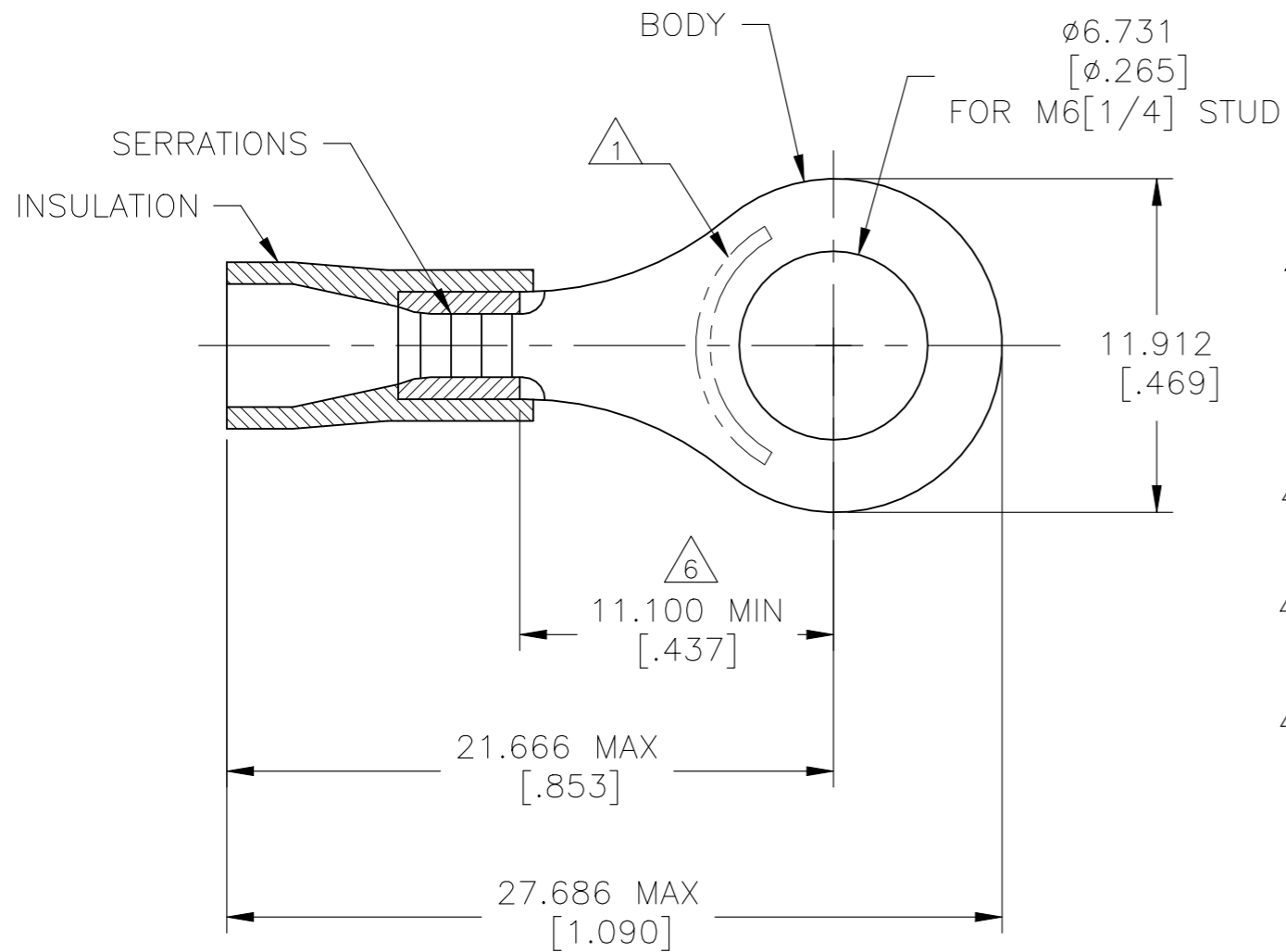

- 1 STAMP AMP 16-14\* APPROX AS SHOWN
- 2. WIRE INSULATION DIAMETER:  $\phi 2.997 - 4.902$  [ $\phi .118 - .193$ ]
- 3. BODY MATERIAL THK:  $0.787 \pm 0.051$  [ $.031 \pm .002$ ]
- 4 MATERIAL: BODY - CU PER ASTM B152  
INSULATION - PVC
- 5 FINISH: BODY - TIN PLATE  $0.00254$  [ $.000100$ ] MIN EXT THK PER ASTM B545  
INSULATION COLOR - BLUE
- 6 APPLIES FROM EDGE OF METAL WIRE BARREL TO CENTER OF STUD HOLE

100	RT025-060-V	1SET121012R0000	34162
QTY	DESIGNATION	ENTRELEC PN	TE PN

MAX RECOMMENDED OPERATING TEMPERATURE: 105°C [221° F]  VOLTAGE RATING: 600V (1000 V SIGNS OR FIXTURES)  CIRCULAR MIL AREA: 1.04-2.62mm <sup>2</sup> [2,050-5,180] SOLID OR STRANDED	THIS DRAWING IS A CONTROLLED DOCUMENT.		DWN 11SEP2020 GOPALAKRISHNA HV CHK 11SEP2020 ROHDE DANIEL F APVD 11SEP2020 ROHDE DANIEL F		<b>ENTRELEC</b> Electrical Solutions  TERMINAL, RING TONGUE, PLASTI-GRIP WIRE SIZE: 16-14 AWG				
	DIMENSIONS: mm [INCHES]	TOLERANCES UNLESS OTHERWISE SPECIFIED: 0 PLC ± - 1 PLC ± - 2 PLC ± - 3 PLC ± 0.127[.005] 4 PLC ± - ANGLES ± -	PRODUCT SPEC UL 486A-B APPLICATION SPEC 114-2161						NAME
	MATERIAL	FINISH	WEIGHT CUSTOMER DRAWING		A3	00779	C-1	SET121012R0000	-
	- 4	- 5	SCALE 4:1		SHEET 1 OF 1	REV A			