

THIS DRAWING IS UNPUBLISHED. RELEASED FOR PUBLICATION 20  
 © COPYRIGHT 20 BY TE CONNECTIVITY ALL RIGHTS RESERVED.

LOC		DIST		REVISIONS			
P	LTR	DESCRIPTION	DATE	DWN	APVD		
	A	ECR-14-000387	10JAN2014	LW	PY		
	A1	ECR-14-015136	10OCT2014	LW	PY		
	A2	ECR-15-005723	13APR2015	KR	TD		
	B	ECR-18-001422	26MAR2018	SG	SM		

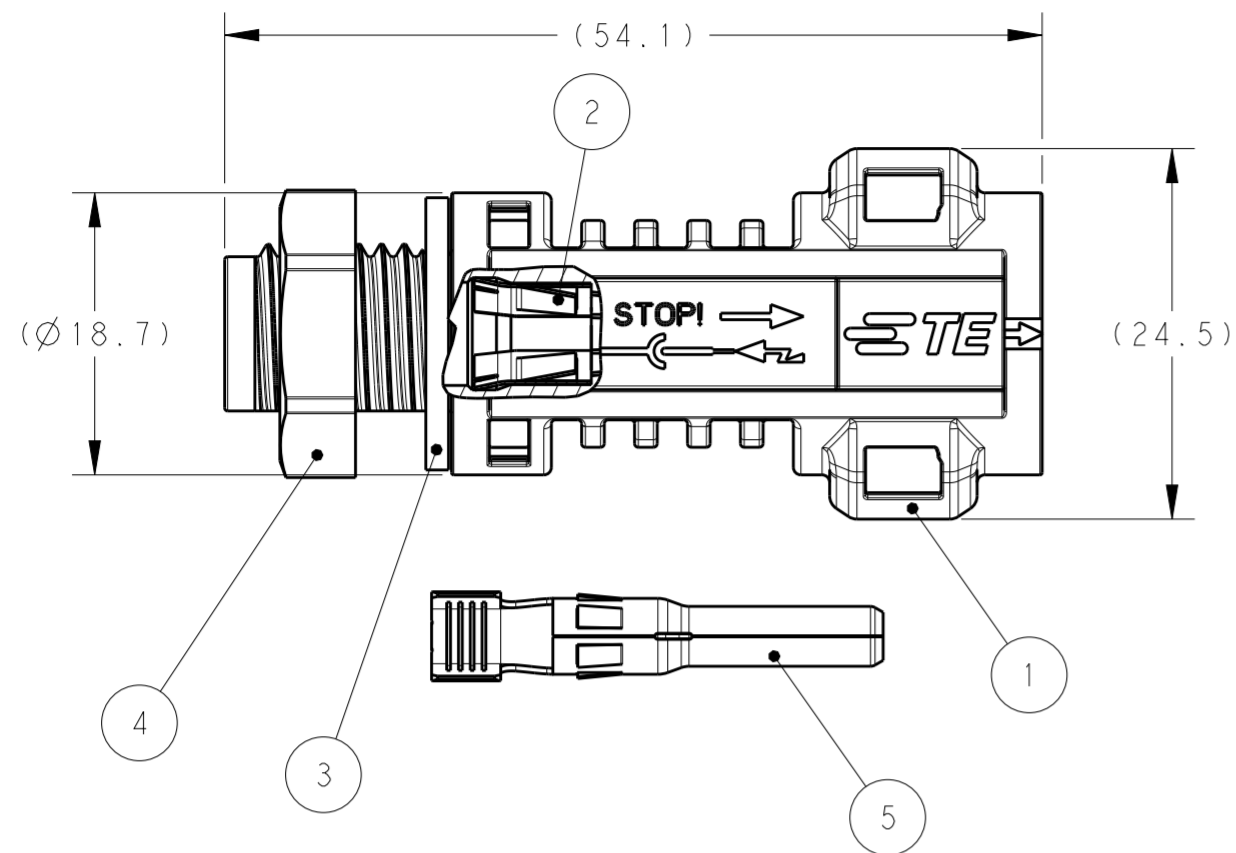

- 1 FLAT SEAL ASSEMBLED ON PIN HOUSING
- 2 NUT ENCLOSE LOOSELY
- 3 RECOMMENDED TIGHTENING TORQUE FOR NUT (ITEM NO.4) 1.0-1.2Nm WHEN ASSEMBLING AT PANEL WALL
- 4 USE ONLY CRIMPING TOOL OF TE CONNECTIVITY TO CRIMP CONTACT.
  - A. CRIMPING TOOL PN 6-1579014-9 WILL BE USED FOR CRIMPING THE CONTACTS HAVING WIRE SIZE 2.5mm<sup>2</sup> and 4.0mm<sup>2</sup>.
  - B. CRIMPING TOOL PN 6-1579014-8 WILL BE USED FOR CRIMPING THE CONTACTS HAVING WIRE SIZE 4.0mm<sup>2</sup> and 6.0mm<sup>2</sup>.

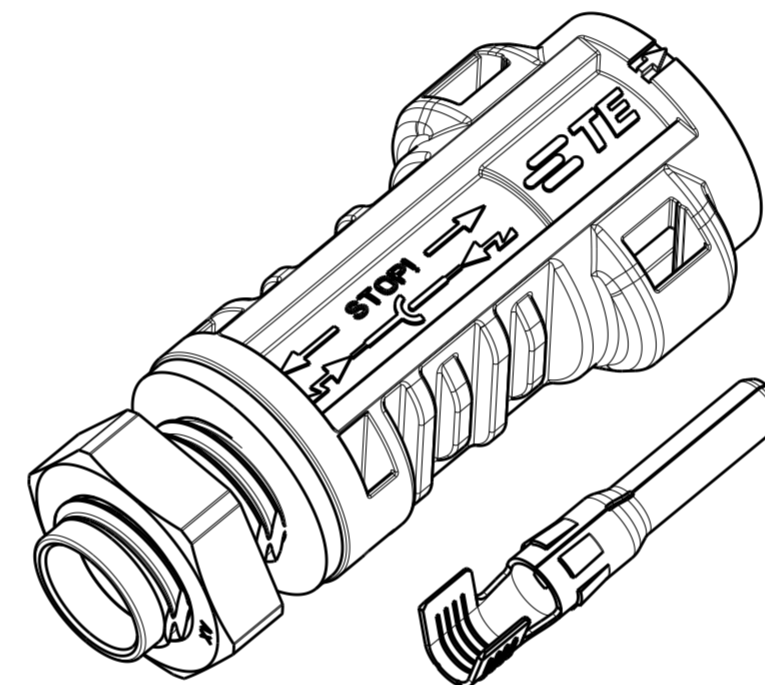
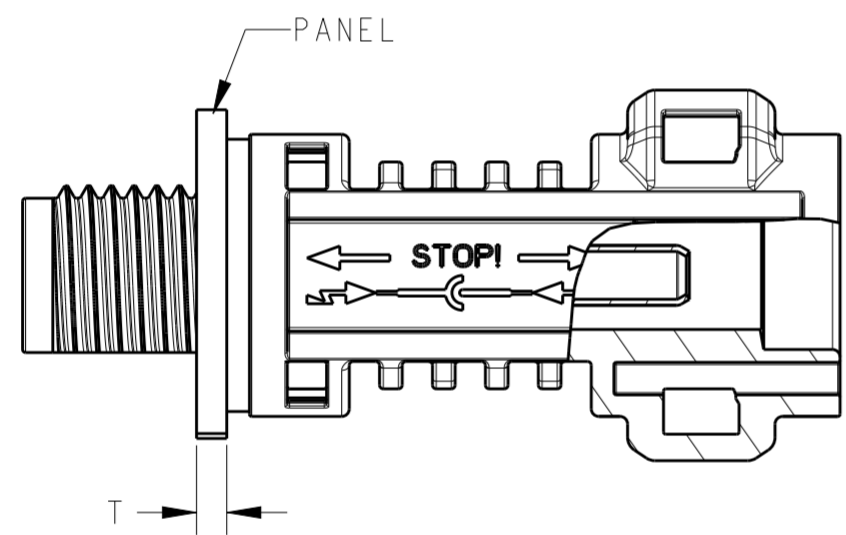

SCALE 2:1

-1 AS SHOWN

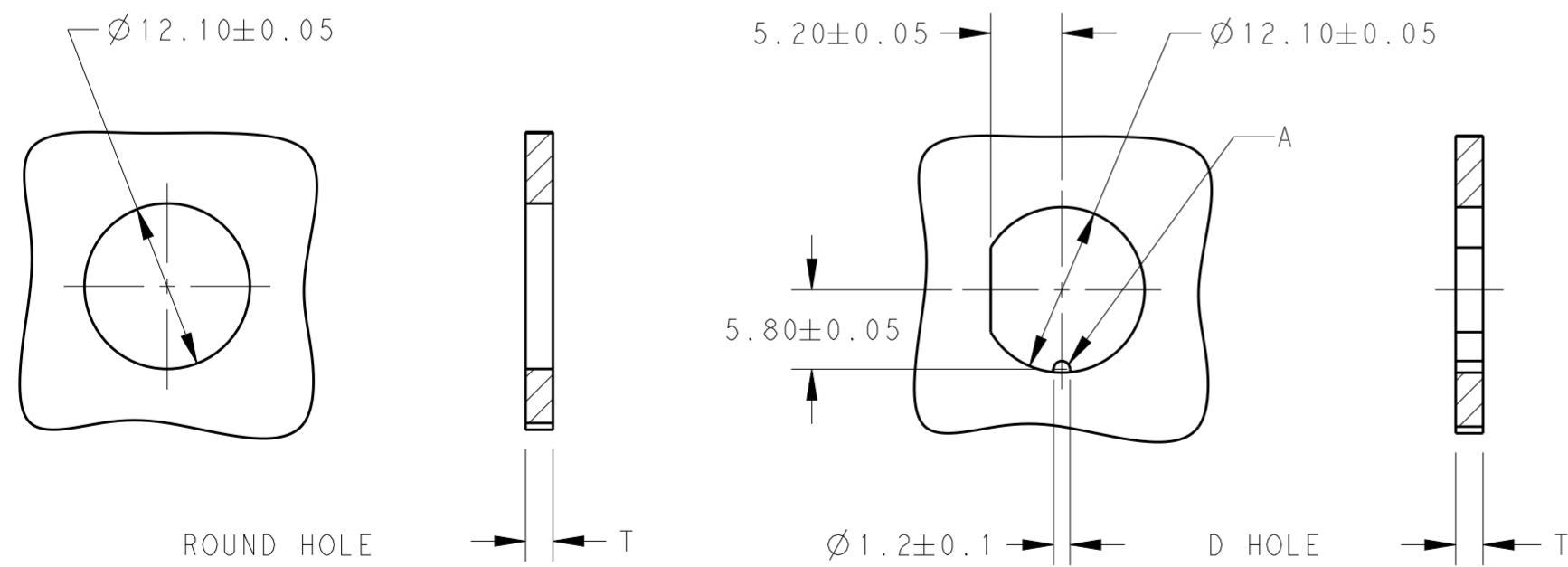

ROUND HOLE

RECOMMENDED MOUNTING HOLE

T(PANEL THICKNESS): 2-6mm  
 FEATURE A DETERMINED BY CUSTOMER

QUANTITY	DESCRIPTION	ITEM
100	PACKAGING	
1000	ORDER-NO.	
1	PIN CONTACT, 2.5mm <sup>2</sup> /14AWG	4A 5
1	PIN CONTACT, 4~6mm <sup>2</sup> /10~12AWG	4B
1	NUT M12x1.5	2 4
1	FLAT SEAL	1 3
1	METAL CLIP RING	2
1	PIN HOUSING	1

THIS DRAWING IS A CONTROLLED DOCUMENT.

DIMENSIONS:	TOLERANCES UNLESS OTHERWISE SPECIFIED:	DWN	28MAR2013	TE Connectivity
mm	0 PLC ±	CHRIS WANG	28MAR2013	
	1 PLC ±0.3	CHK	DANIEL TAO	
	2 PLC ±	APVD	PETER YIN	
	3 PLC ±	PRODUCT SPEC	108-106122	NAME
	4 PLC ±	APPLICATION SPEC	114-106122	PIN CONNECTOR KITS
MATERIAL	ANGLES ±	WEIGHT	-	PV4 PANEL MOUNTED CONNECTOR
	FINISH	Customer Drawing	SCALE 2:1	RESTRICTED TO

SIZE: A2 CAGE CODE: 00779 DRAWING NO: C-1971919 SHEET 1 OF 1 REV B