

REVISIONS					
P	LTM	DESCRIPTION	DATE	OWN	APVD
C3		REVISED PER ECO-18-005108	03APR2018	JMS	GK
C4		REVISED PER ECO-19-009349	21JUN2019	JMS	HC
C5		REVISED PER ECO-21-002920	03MAR2021	CN	HC
C6		REVISED PER ECN-24-278905	08AUG2024	CKM	HC

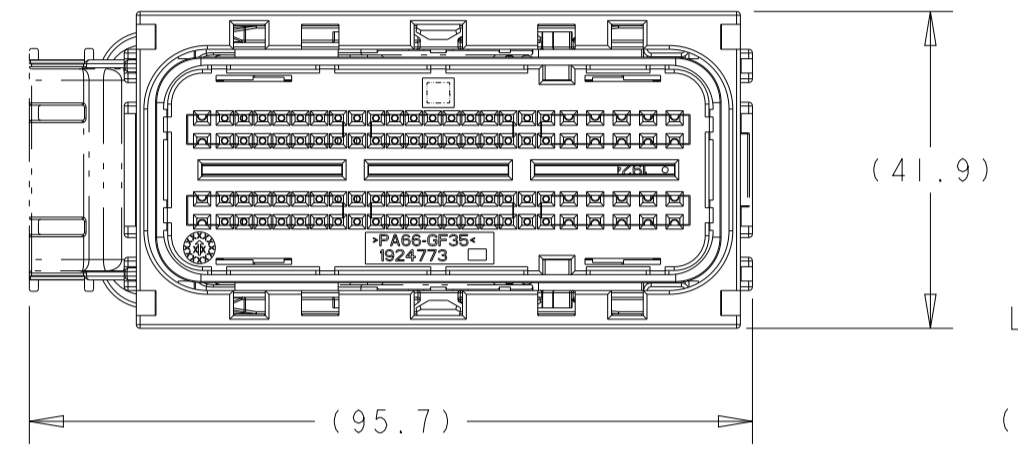

LEFT EXIT PLUG ASSEMBLY SHOWN WITH OPTIONAL WIRE COVER ASSEMBLY (MUST BE PURCHASED SEPARATELY) SCALE 1:1

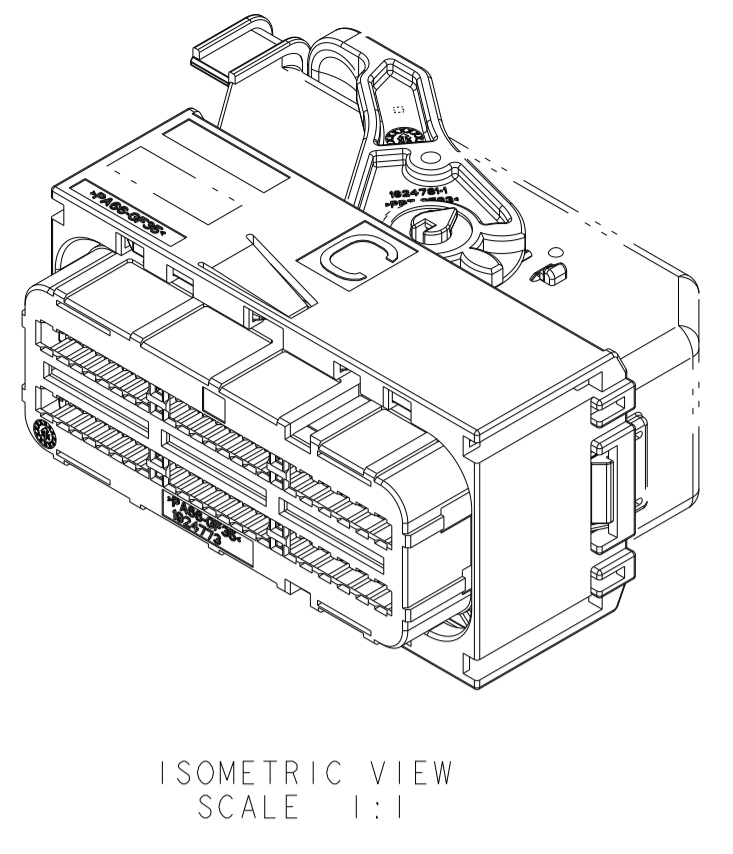
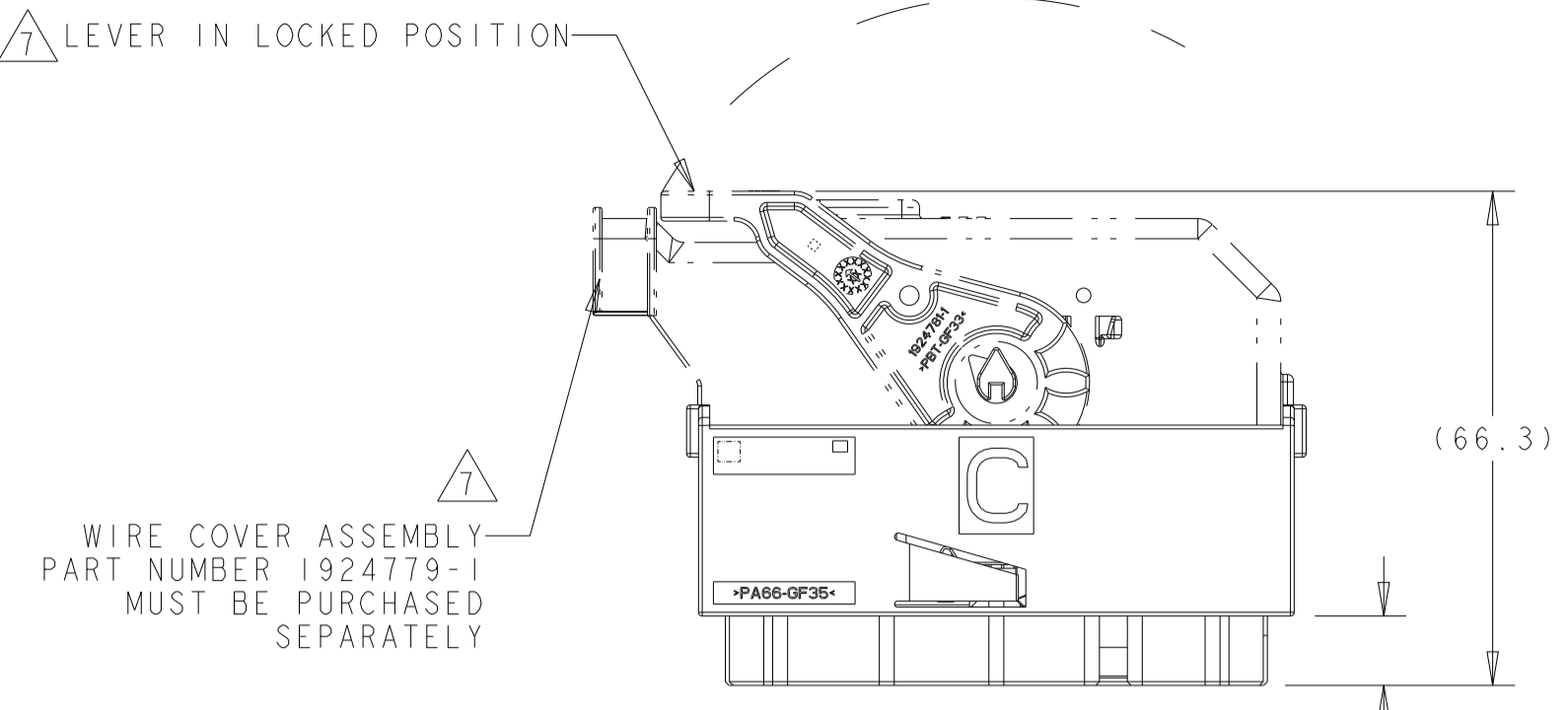
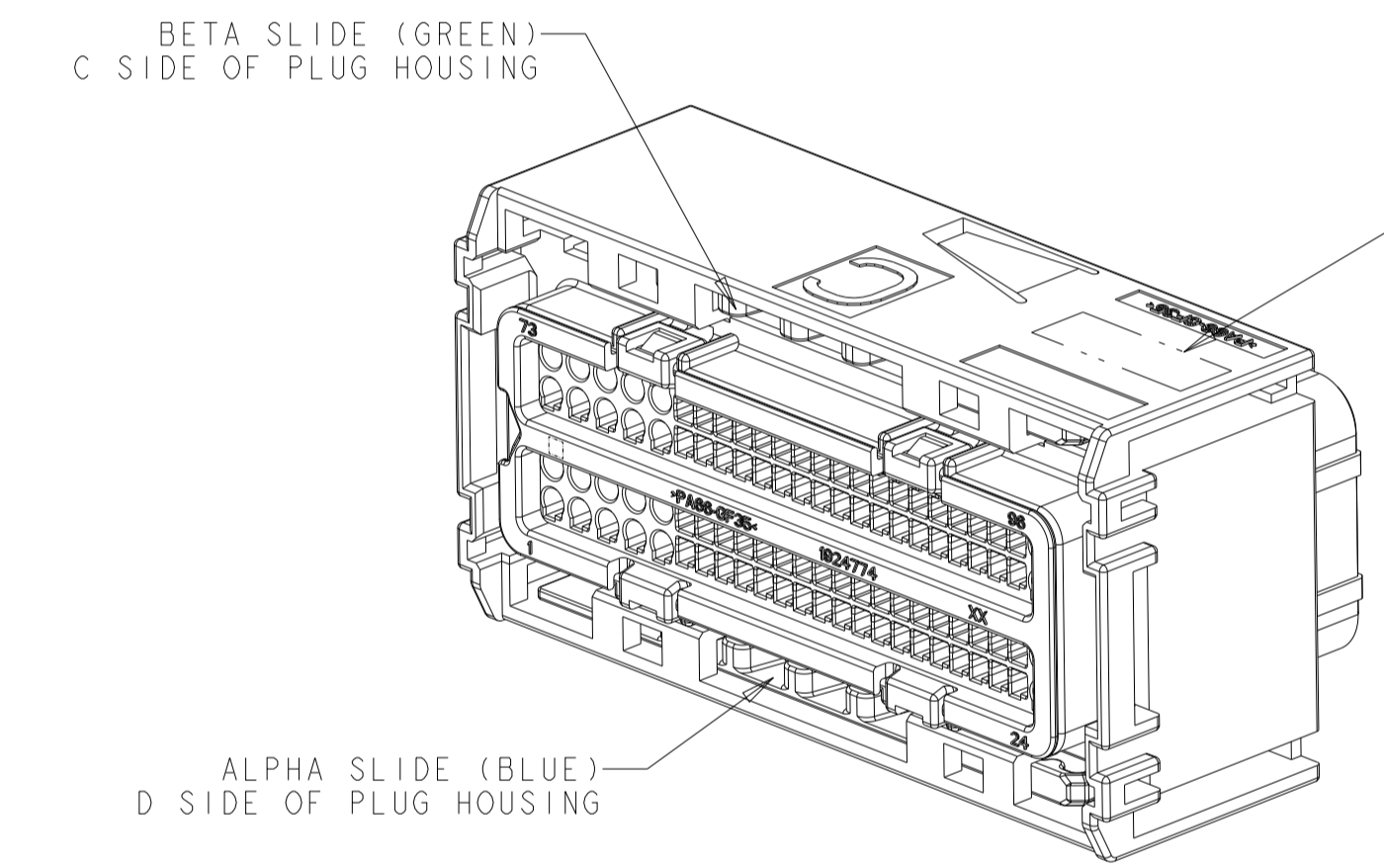
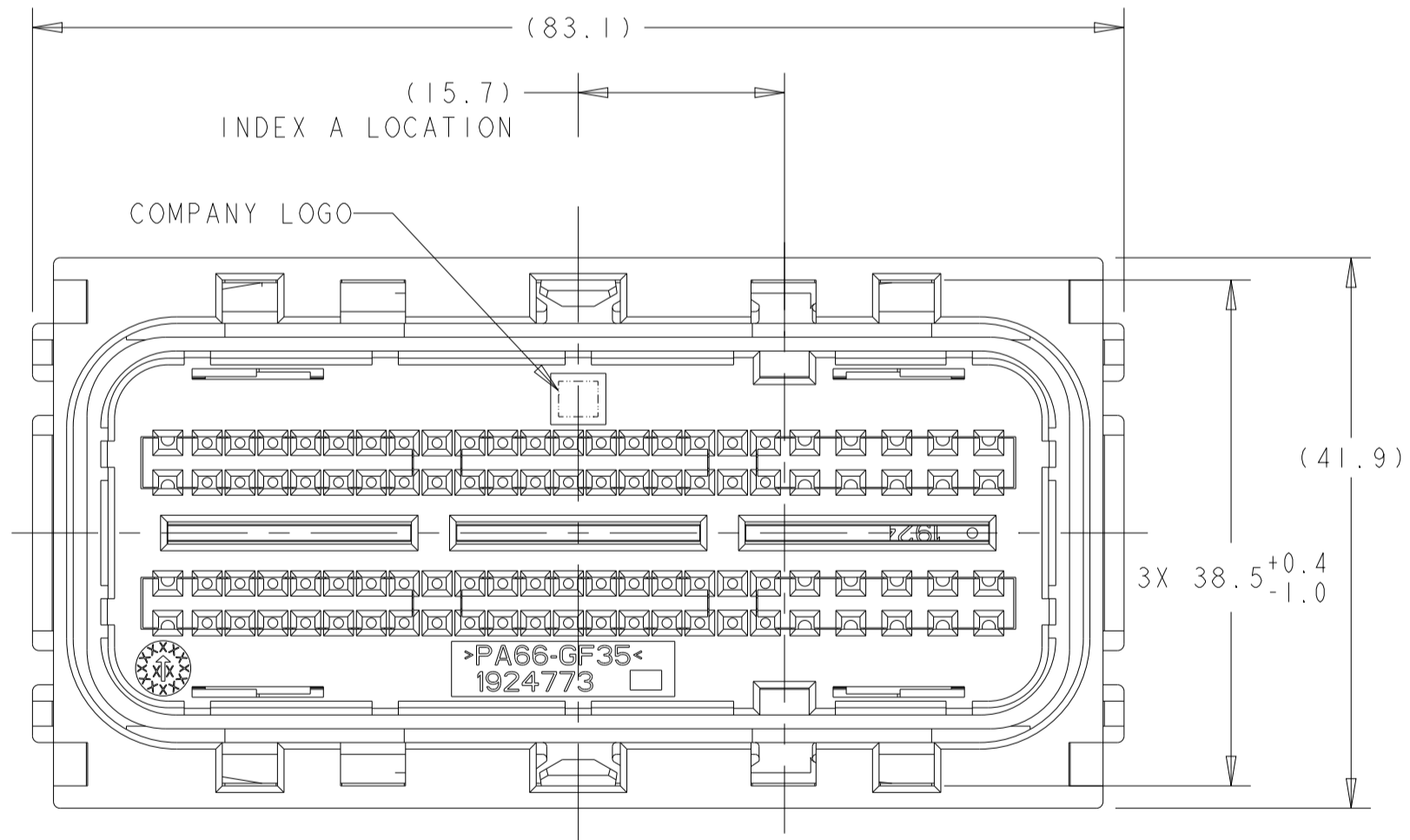
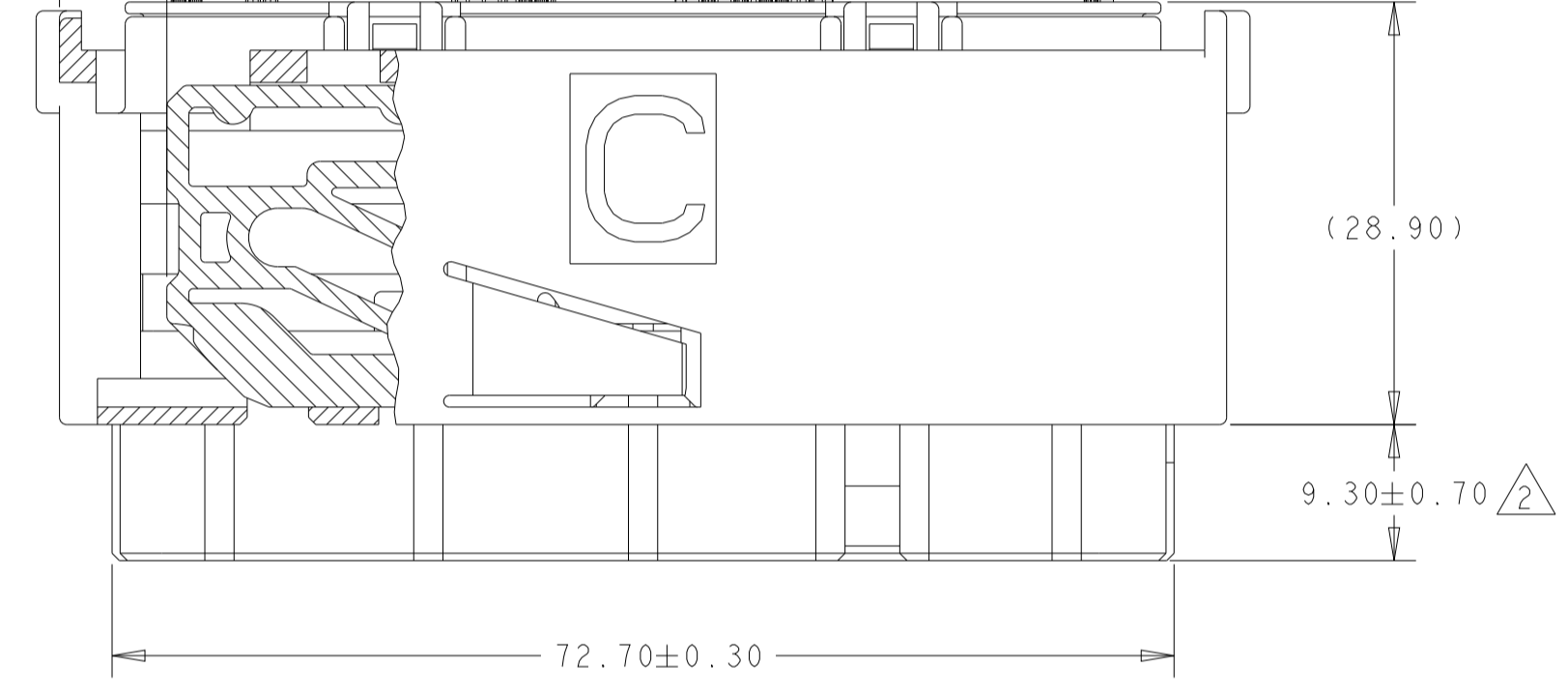
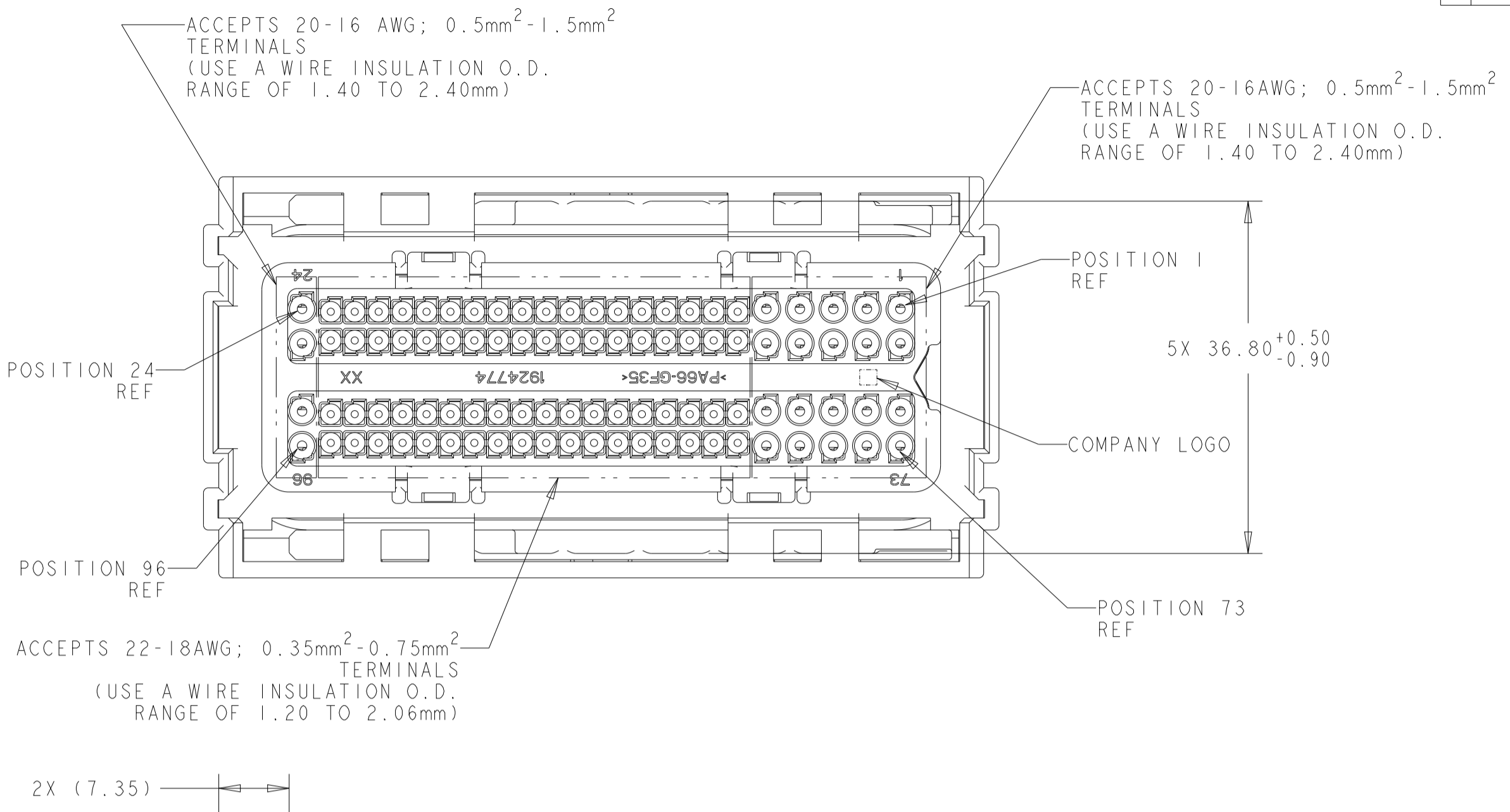

ASSEMBLY PART NUMBER AND DATE CODE MARKING

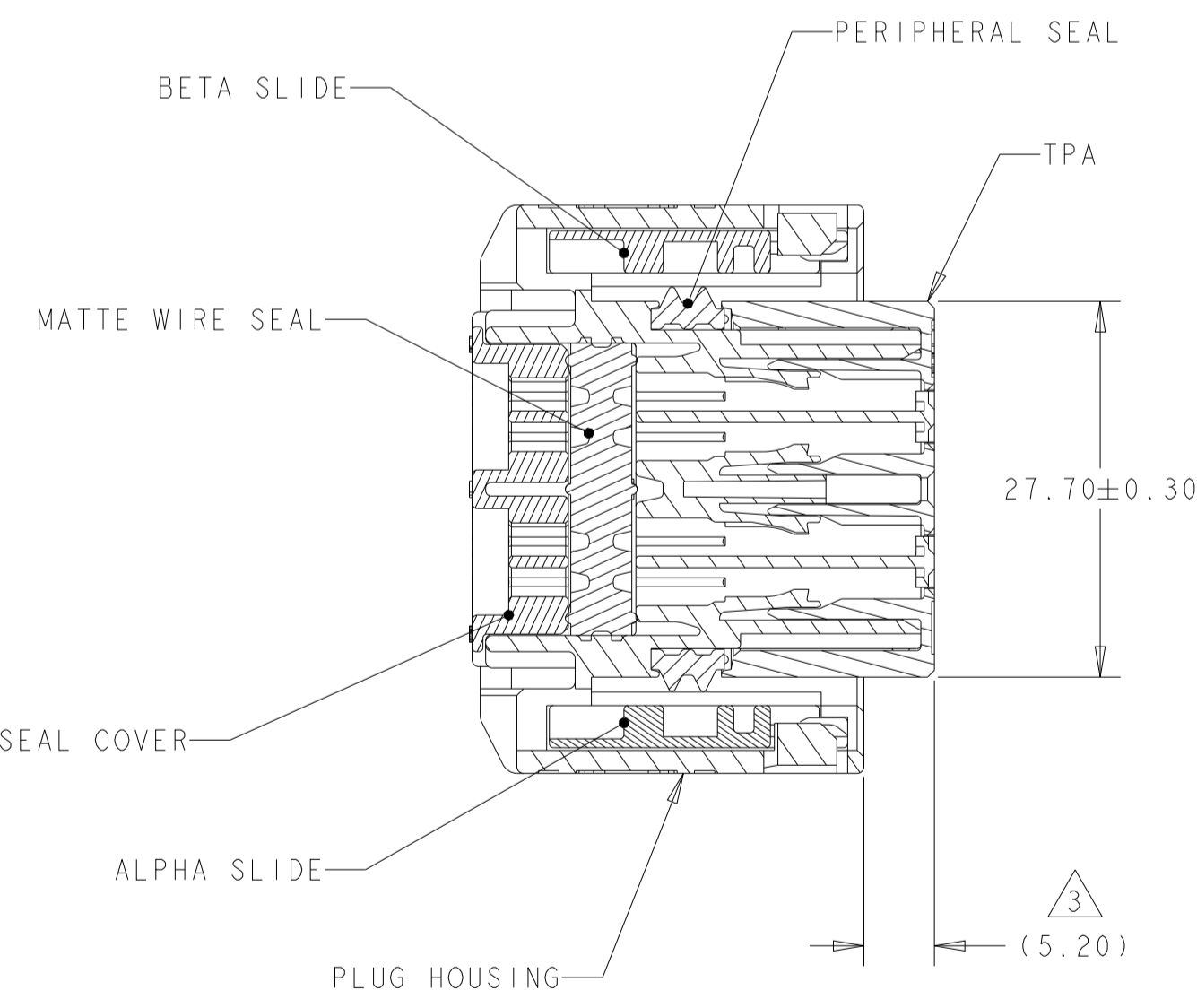

(METHOD FOR IDENTIFYING EXIT ORIENTATION)

- 1. PLUG HOUSING AND SEAL COVER: NYLON 6/6, BLACK.
TPA: NYLON 6/6, COLOR - SEE TABLE.
MATTE WIRE SEAL: SILICONE, LIGHT BLUE.
PERIPHERAL SEAL: SILICONE, GREEN.
ALPHA SLIDE: NYLON 6/6, BLUE.
BETA SLIDE: NYLON 6/6, GREEN.
- 2. TPA SHOWN IN PRE-LATCHED, AS SHIPPED, POSITION.
- 3. TPA SHOWN IN CLOSED POSITION.
- 4. SEE TABLE ON SHEET 2 FOR SEAL COVER PIN OUT CONFIGURATION.

- 5. PLUG ASSEMBLY MATES WITH TE CONNECTIVITY INTERFACE DRAWING 1924771_INT, POLARIZATION A.
- 6. PLUG ASSEMBLY WILL ACCEPT THE FOLLOWING GET TERMINAL PART NUMBERS:
 - 1393364-1 (GOLD 22AWG; 0.35mm²)
 - 1393365-1 (GOLD 18-20AWG; 0.75mm²-0.5mm²)
 - 1924878-1 (TIN/SILVER 22AWG; 0.35mm²)
 - 1924879-1 (TIN/SILVER 18-20AWG; 0.75mm²-0.5mm²)
 - 1924782-1 (TIN/SILVER 1.0mm²)
 - 1924880-1 (TIN/SILVER 16AWG; 1.5mm²)

- 7. WIRE DRESS ASSEMBLY MUST BE INSTALLED ONTO PLUG ASSEMBLY WITH LEVER IN LOCKED POSITION.
- 8. APPLICATION SPEC'S: 408-10229, 408-10230
- 9. NOTE DELETED.
- 10. FORCE TO SEAT TPA COMPONENT FROM PRE-SET TO LOCKED (FULLY LOADED W/ TERMINALS) TO BE 83N MAX.
- 11. FORCE TO MOVE TPA FROM FULLY LOCKED TO PRE-SET TO BE 115N MAX. FLAT BLADE SCREWDRIVER SUGGESTED FOR REMOVAL OF TPA.

9-2359497-9	ALL CLOSED	GRAY	A	9-1924940-9
2-2359497-6	SEE TABLE, SH 2	GRAY	A	2-1924940-6
2-2359497-5	SEE TABLE, SH 2	GRAY	A	2-1924940-5
2-2359497-4	SEE TABLE, SH 2	GRAY	A	2-1924940-4
2-2359497-3	SEE TABLE, SH 2	GRAY	A	2-1924940-3
2-2359497-2	SEE TABLE, SH 2	GRAY	A	2-1924940-2
2-2359497-1	SEE TABLE, SH 2	GRAY	A	2-1924940-1
2-2359497-0	SEE TABLE, SH 2	GRAY	A	2-1924940-0
1-2359497-9	SEE TABLE, SH 2	GRAY	A	1-1924940-9
1-2359497-8	SEE TABLE, SH 2	GRAY	A	1-1924940-8
1-2359497-7	SEE TABLE, SH 2	GRAY	A	1-1924940-7
1-2359497-6	SEE TABLE, SH 2	GRAY	A	1-1924940-6
1-2359497-5	SEE TABLE, SH 2	GRAY	A	1-1924940-5
1-2359497-4	SEE TABLE, SH 2	GRAY	A	1-1924940-4
1-2359497-3	SEE TABLE, SH 2	GRAY	A	1-1924940-3
1-2359497-2	SEE TABLE, SH 2	GRAY	A	1-1924940-2
1-2359497-1	SEE TABLE, SH 2	GRAY	A	1-1924940-1
1-2359497-0	SEE TABLE, SH 2	GRAY	A	1-1924940-0
2359497-9	SEE TABLE, SH 2	GRAY	A	1924940-9
2359497-8	SEE TABLE, SH 2	GRAY	A	1924940-8
2359497-7	SEE TABLE, SH 2	GRAY	A	1924940-7
2359497-6	SEE TABLE, SH 2	GRAY	A	1924940-6
2359497-5	SEE TABLE, SH 2	GRAY	A	1924940-5
2359497-4	SEE TABLE, SH 2	GRAY	A	1924940-4
2359497-3	SEE TABLE, SH 2	GRAY	A	1924940-3
2359497-2	SEE TABLE, SH 2	GRAY	A	1924940-2
2359497-1	SEE TABLE, SH 2	GRAY	A	1924940-1
2359497-0	SEE TABLE, SH 2	GRAY	A	1924940-0
2359497-9	SEE TABLE, SH 2	GRAY	A	1924940-9
2359497-8	SEE TABLE, SH 2	GRAY	A	1924940-8
2359497-7	SEE TABLE, SH 2	GRAY	A	1924940-7
2359497-6	SEE TABLE, SH 2	GRAY	A	1924940-6
2359497-5	SEE TABLE, SH 2	GRAY	A	1924940-5
2359497-4	SEE TABLE, SH 2	GRAY	A	1924940-4
2359497-3	SEE TABLE, SH 2	GRAY	A	1924940-3
2359497-2	SEE TABLE, SH 2	GRAY	A	1924940-2
2359497-1	SEE TABLE, SH 2	GRAY	A	1924940-1
2359497-0	SEE TABLE, SH 2	GRAY	A	1924940-0
2359497-9	SEE TABLE, SH 2	GRAY	A	1924940-9
2359497-8	SEE TABLE, SH 2	GRAY	A	1924940-8
2359497-7	SEE TABLE, SH 2	GRAY	A	1924940-7
2359497-6	SEE TABLE, SH 2	GRAY	A	1924940-6
2359497-5	SEE TABLE, SH 2	GRAY	A	1924940-5
2359497-4	SEE TABLE, SH 2	GRAY	A	1924940-4
2359497-3	SEE TABLE, SH 2	GRAY	A	1924940-3
2359497-2	SEE TABLE, SH 2	GRAY	A	1924940-2
2359497-1	SEE TABLE, SH 2	GRAY	A	1924940-1
2359497-0	SEE TABLE, SH 2	GRAY	A	1924940-0
2359497-9	SEE TABLE, SH 2	GRAY	A	1924940-9
2359497-8	SEE TABLE, SH 2	GRAY	A	1924940-8
2359497-7	SEE TABLE, SH 2	GRAY	A	1924940-7
2359497-6	SEE TABLE, SH 2	GRAY	A	1924940-6
2359497-5	SEE TABLE, SH 2	GRAY	A	1924940-5
2359497-4	SEE TABLE, SH 2	GRAY	A	1924940-4
2359497-3	SEE TABLE, SH 2	GRAY	A	1924940-3
2359497-2	SEE TABLE, SH 2	GRAY	A	1924940-2
2359497-1	SEE TABLE, SH 2	GRAY	A	1924940-1
2359497-0	SEE TABLE, SH 2	GRAY	A	1924940-0
2359497-9	SEE TABLE, SH 2	GRAY	A	1924940-9
2359497-8	SEE TABLE, SH 2	GRAY	A	1924940-8
2359497-7	SEE TABLE, SH 2	GRAY	A	1924940-7
2359497-6	SEE TABLE, SH 2	GRAY	A	1924940-6
2359497-5	SEE TABLE, SH 2	GRAY	A	1924940-5
2359497-4	SEE TABLE, SH 2	GRAY	A	1924940-4
2359497-3	SEE TABLE, SH 2	GRAY	A	1924940-3
2359497-2	SEE TABLE, SH 2	GRAY	A	1924940-2
2359497-1	SEE TABLE, SH 2	GRAY	A	1924940-1
2359497-0	SEE TABLE, SH 2	GRAY	A	1924940-0
2359497-9	SEE TABLE, SH 2	GRAY	A	1924940-9
2359497-8	SEE TABLE, SH 2	GRAY	A	1924940-8
2359497-7	SEE TABLE, SH 2	GRAY	A	1924940-7
2359497-6	SEE TABLE, SH 2	GRAY	A	1924940-6
2359497-5	SEE TABLE, SH 2	GRAY	A	1924940-5
2359497-4	SEE TABLE, SH 2	GRAY	A	1924940-4
2359497-3	SEE TABLE, SH 2	GRAY	A	1924940-3
2359497-2	SEE TABLE, SH 2	GRAY	A	1924940-2
2359497-1	SEE TABLE, SH 2	GRAY	A	1924940-1
2359497-0	SEE TABLE, SH 2	GRAY	A	1924940-0
2359497-9	SEE TABLE, SH 2	GRAY	A	1924940-9
2359497-8	SEE TABLE, SH 2	GRAY	A	1924940-8
2359497-7	SEE TABLE, SH 2	GRAY	A	1924940-7
2359497-6	SEE TABLE, SH 2	GRAY	A	1924940-6
2359497-5	SEE TABLE, SH 2	GRAY	A	1924940-5
2359497-4	SEE TABLE, SH 2	GRAY	A	1924940-4
2359497-3	SEE TABLE, SH 2	GRAY	A	1924940-3
2359497-2	SEE TABLE, SH 2	GRAY	A	1924940-2
2359497-1	SEE TABLE, SH 2	GRAY	A	1924940-1
2359497-0	SEE TABLE, SH 2	GRAY	A	1924940-0
2359497-9	SEE TABLE, SH 2	GRAY	A	1924940-9
2359497-8	SEE TABLE, SH 2	GRAY	A	1924940-8
2359497-7	SEE TABLE, SH 2	GRAY	A	1924940-7
2359497-6	SEE TABLE, SH 2	GRAY	A	1924940-6
2359497-5	SEE TABLE, SH 2	GRAY	A	1924940-5
2359497-4	SEE TABLE, SH 2	GRAY	A	1924940-4
2359497-3	SEE TABLE, SH 2	GRAY	A	1924940-3
2359497-2	SEE TABLE, SH 2	GRAY	A	1924940-2
2359497-1	SEE TABLE, SH 2	GRAY	A	1924940-1
2359497-0	SEE TABLE, SH 2	GRAY	A	1924940-0
2359497-9	SEE TABLE, SH 2	GRAY	A	1924940-9
2359497-8	SEE TABLE, SH 2	GRAY	A	1924940-8
2359497-7	SEE TABLE, SH 2	GRAY	A	1924940-7
2359497-6	SEE TABLE, SH 2	GRAY	A	1924940-6
2359497-5	SEE TABLE, SH 2	GRAY	A	1924940-5
2359497-4	SEE TABLE, SH 2	GRAY	A	1924940-4
2359497-3	SEE TABLE, SH 2	GRAY	A	1924940-3
2359497-2	SEE TABLE, SH 2	GRAY	A	1924940-2
2359497-1	SEE TABLE, SH 2	GRAY	A	1924940-1
2359497-0	SEE TABLE, SH 2	GRAY	A	1924940-0
2359497-9	SEE TABLE, SH 2	GRAY	A	1924940-9
2359497-8	SEE TABLE, SH 2	GRAY	A	1924940-8
2359497-7	SEE TABLE, SH 2	GRAY	A	1924940-7
2359497-6	SEE TABLE, SH 2	GRAY	A	1924940-6
2359497-5	SEE TABLE, SH 2	GRAY	A	1924940-5
2359497-4	SEE TABLE, SH 2	GRAY	A	1924940-4
2359497-3	SEE TABLE, SH 2	GRAY	A	1924940-3
2359497-2	SEE TABLE, SH 2	GRAY	A	1924940-2
2359497-1	SEE TABLE, SH 2	GRAY	A	1924940-1
2359497-0	SEE TABLE, SH 2	GRAY	A	1924940-0
2359497-9	SEE TABLE, SH 2	GRAY	A	1924940-9
2359497-8	SEE TABLE, SH 2	GRAY	A	1924940-8
2359497-7	SEE TABLE, SH 2	GRAY	A	1924940-7
2359497-6	SEE TABLE, SH 2	GRAY	A	1924940-6
2359497-5	SEE TABLE, SH 2	GRAY	A	1924940-5
2359497-4	SEE TABLE, SH 2	GRAY	A	1924940-4
2359497-3	SEE TABLE, SH 2	GRAY	A	1924940-3
2359497-2	SEE TABLE, SH 2	GRAY	A	1924940-2
2359497-1	SEE TABLE, SH 2	GRAY	A	1924940-1
2359497-0	SEE TABLE, SH 2	GRAY	A	1924940-0
2359497-9	SEE TABLE, SH 2	GRAY	A	1924940-9
2359497-8	SEE TABLE, SH 2	GRAY	A	1924940-8
2359497-7	SEE TABLE, SH 2	GRAY	A	1924940-7
2359497-6	SEE TABLE, SH 2	GRAY	A	1924940-6
2359497-5	SEE TABLE, SH 2	GRAY	A	1924940-5
2359497-4	SEE TABLE, SH 2	GRAY	A	1924940-4
2359497-3	SEE TABLE, SH 2	GRAY	A	1924940-3
2359497-2	SEE TABLE, SH 2	GRAY	A	1924940-2
2359497-1	SEE TABLE, SH 2	GRAY	A	1924940-1
2359497-0	SEE TABLE, SH 2	GRAY	A	1924940-0
2359497-9	SEE TABLE, SH 2	GRAY	A	1924940-9
2359497-8	SEE TABLE, SH 2	GRAY	A	1924940-8
2359497-7	SEE TABLE, SH 2	GRAY	A	1924940-7
2359497-6	SEE TABLE, SH 2	GRAY	A	1924940-6
2359497-5	SEE TABLE, SH 2	GRAY	A	1924940-5
2359497-4	SEE TABLE, SH 2	GRAY	A	1924940-4
2359497-3	SEE TABLE, SH 2	GRAY	A	1924940-3
2359497-2	SEE TABLE, SH 2	GRAY	A	1924940-2
2359497-1	SEE TABLE, SH 2	GRAY	A	1924940-1
2359497-0	SEE TABLE, SH 2	GRAY	A	1924940-0
2359497-9	SEE TABLE, SH 2	GRAY	A	1924940-9
2359497-8	SEE TABLE, SH 2	GRAY	A	1924940-8
2359497-7	SEE TABLE, SH 2	GRAY	A	1924940-7
2359497-6	SEE TABLE, SH 2	GRAY	A	1924940-6
2359497-5	SEE TABLE, SH 2	GRAY	A	1924940-5
2359497-4	SEE TABLE, SH 2	GRAY	A	1924940-4
2359497-3	SEE TABLE, SH 2	GRAY	A	1924940-3
2359497-2	SEE TABLE, SH 2	GRAY	A	1924940-2
2359497-1	SEE TABLE, SH 2	GRAY	A	1924940-1
2359497-0	SEE TABLE, SH 2	GRAY	A	1924940-0
2359497-9	SEE TABLE, SH 2	GRAY	A	1924940-9
2359497-8	SEE TABLE, SH 2	GRAY	A	1924940-8
2359497-7	SEE TABLE, SH 2	GRAY	A	1924940-7
2359497-6	SEE TABLE, SH 2	GRAY	A	1924940-6
2359497-5	SEE TABLE, SH 2	GRAY	A	1924940-5
2359497-4	SEE TABLE, SH 2	GRAY	A	1924940-4
2359497-3	SEE TABLE, SH 2	GRAY	A	1924940-3
2359497-2	SEE TABLE, SH 2	GRAY	A	1924940-2
2359497-1	SEE TABLE, SH 2	GRAY	A	1924940-1
2359497-0	SEE TABLE, SH 2	GRAY	A	1924940-0
2359497-9	SEE TABLE, SH 2	GRAY	A	1924940-9
2359497-8	SEE TABLE, SH 2	GRAY	A	1924940-8
2359497-7	SEE TABLE, SH 2	GRAY	A	1924940-7
2359497-6	SEE TABLE, SH 2	GRAY	A	1924940-6
2359497-5	SEE TABLE, SH 2	GRAY	A	1924940-5
2359497-4	SEE TABLE, SH 2	GRAY	A	1924940-4

