

THIS DRAWING IS UNPUBLISHED. RELEASED FOR PUBLICATION 20
 © COPYRIGHT 20 BY TYCO ELECTRONICS CORPORATION. ALL RIGHTS RESERVED.

LOC		DIST		REVISIONS			
P	LTR	DESCRIPTION	DATE	DWN	APVD		
	1	PROPOSED	14MAR2005	BW	JPM		
	2	REVISED	16APR2010	RF	JM		

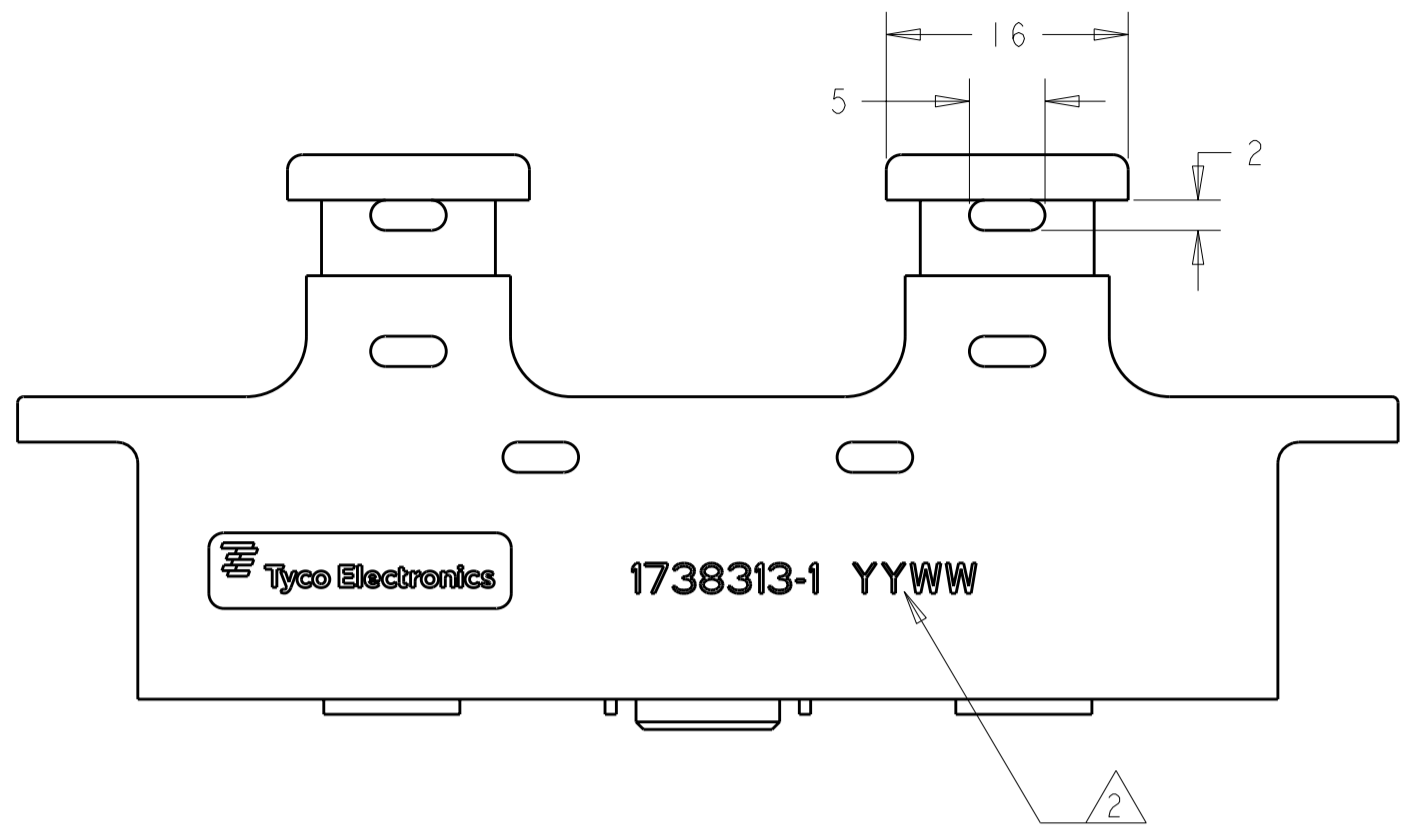

- 1 SHROUD: PEI THERMOPLASTIC PER ASTM D5205
RETAINING NUT: STAINLESS STEEL PER AISI 316.
- 2 DATE CODE - YEAR & WEEK (YY WW).
- 3. THE SHROUD AND LOCKING NUT ARE SHIPPED UNASSEMBLED.
- 4 A SPANNER WRENCH TOOL, TYCO ELECTRONICS P/N 1738220-1 (WITH 1/4-in. ADAPTER) OR 1738221-1 (WITH T-HANDLE) IS USED TO LOCK THE RETAINING NUT TO THE JACKSCREW OF THE CORRESPONDING GPR CONNECTOR.
- 5 TWO POSSIBLE LOCATIONS FOR THE RETAINING NUT.

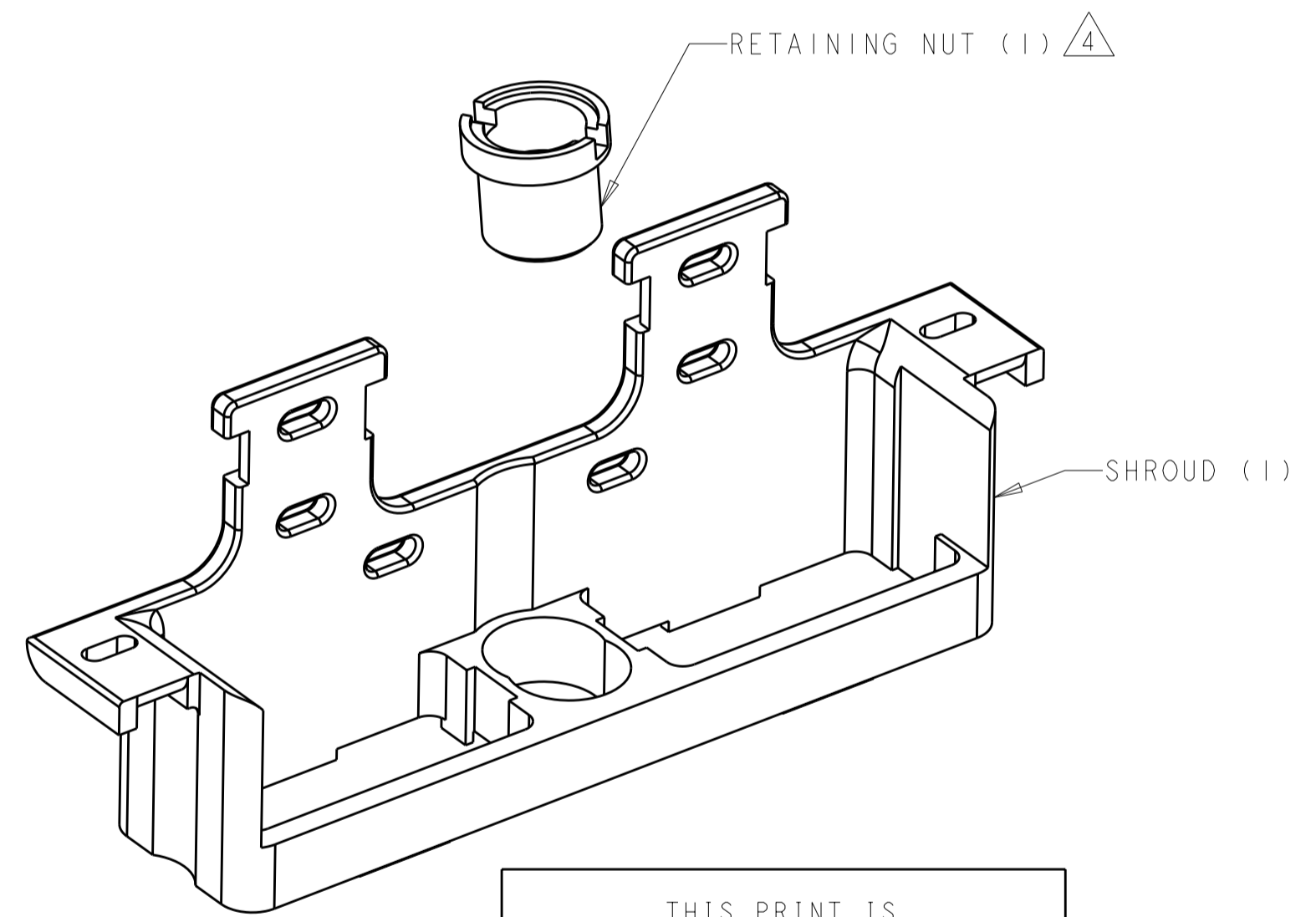
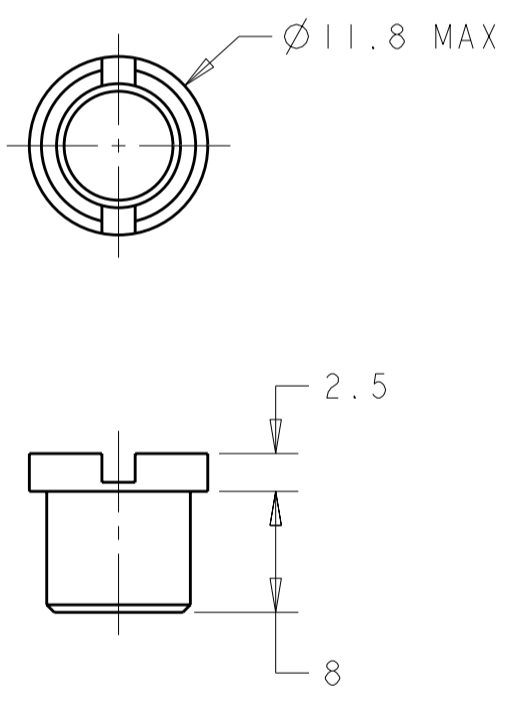
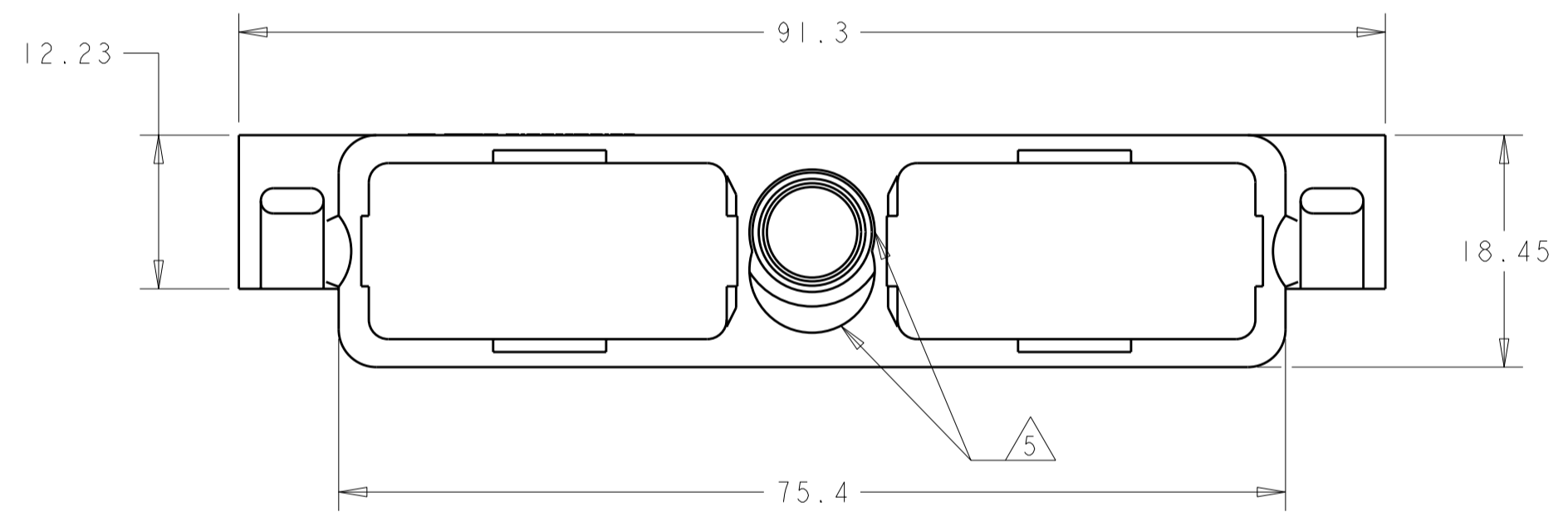

THIS PRINT IS
PRELIMINARY
 UNQUALIFIED PRODUCT
 CONTACT PRODUCT ENGINEERING
 BEFORE USING THIS PRINT

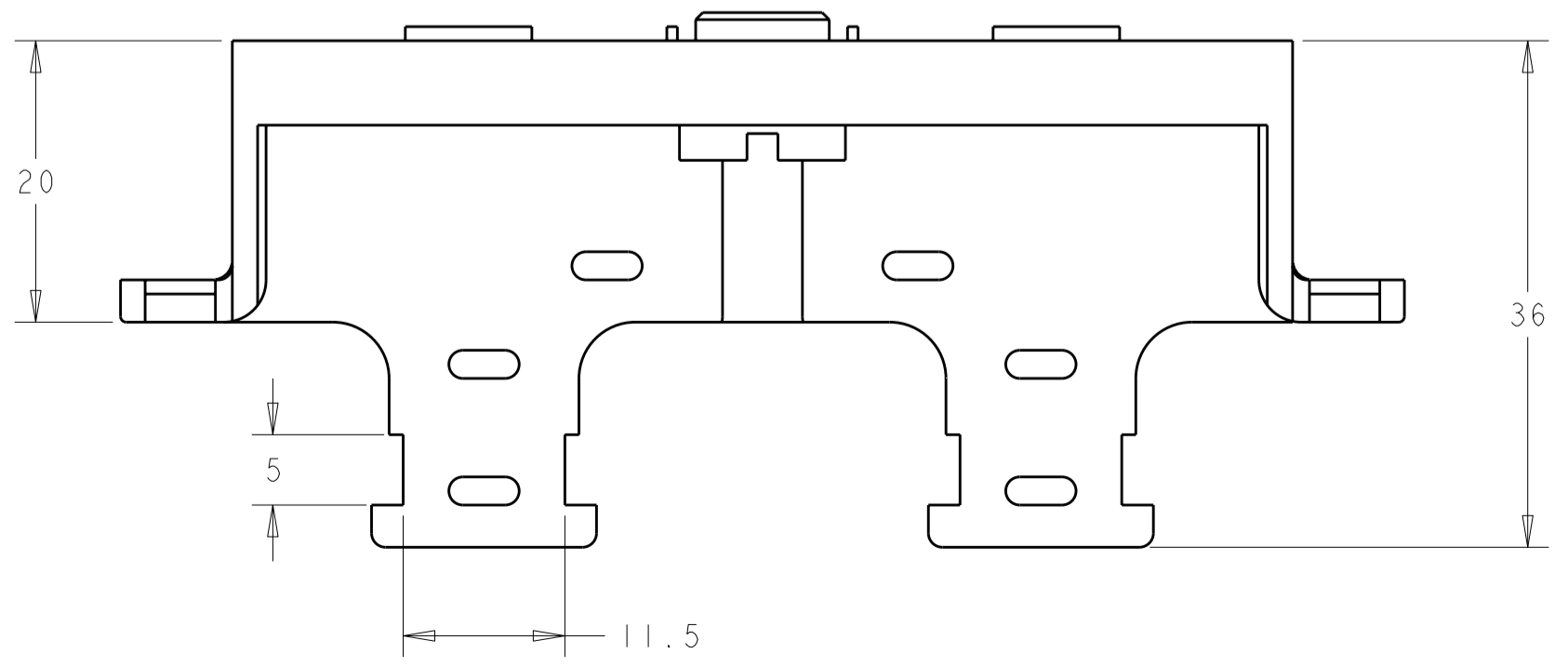

1738313-1
 PART NUMBER

THIS DRAWING IS A CONTROLLED DOCUMENT FOR TYCO ELECTRONICS CORPORATION. IT IS SUBJECT TO CHANGE AND THE CONTROLLING ENGINEERING ORGANIZATION SHOULD BE CONTACTED FOR THE LATEST REVISION.		DWN	14MAR2005	Tyco Electronics Harrisburg, PA 17105-3608	NAME STRAIN RELIEF KIT, STRAIGHT, GPRB2		
DIMENSIONS:		CHK	14MAR2005				
TOLERANCES UNLESS OTHERWISE SPECIFIED:		APVD	14MAR2005				
0 PLC ±0.2 1 PLC ±0.1 2 PLC ±0.1 3 PLC ± 4 PLC ± ANGLES ± FINISH		PRODUCT SPEC	-				
MATERIAL		APPLICATION SPEC	-	SIZE	CAGE CODE	DRAWING NO	RESTRICTED TO
		WEIGHT	-	A2	00779	1738313	-
CUSTOMER DRAWING		SCALE	2:1	SHEET	1	OF	1
		REV	2				