

REVISIONS

P	LTR	DESCRIPTION	DATE	DWN	APVD
	G	STANDARDIZATION OF PLATING & SPLICING	13AUG2024	GVP	KJK

NOTES:

- 1 FOR MINI-APPLICATOR-CRIMPING.
- 2 UNDERCOATING: 1,25µm Ni, SELECTIVE: 0,8µm Au, ZONE 1: 0,5µm MIN. GOLD FLASH.
- 3 UNDERCOATING: 1,25µm Ni, SELECTIVE: 0,8µm Au, GOLDFLASH ON REMAINDER (GOLDFLASH IS NOT MANDATORY ON THE PILOTED CARRIER STRIP).
- 4 UNDERCOATING: 1,25µm Ni, SELECTIVE: 0,4µm Au, NO GOLD FLASH.
- 5 ZONE 1: BRIGHT TIN/LEAD PLATED.
- 6 MATERIAL: PHOSPHOR BRONZE
- 7 FOR STANDARD-APPLICATOR-CRIMPING.
- 8 FOR REELFED-HANDTOOL-CRIMPING.
- 9 24-20 AWG (0,20-0,56 mm²) WITH .055 CRIMPER.
26 AWG (0,12-0,14 mm²) WITH .042 CRIMPER.
- 10 SPLICING - MAXIMUM 1 LOOSE END PER REEL IS ALLOWED.

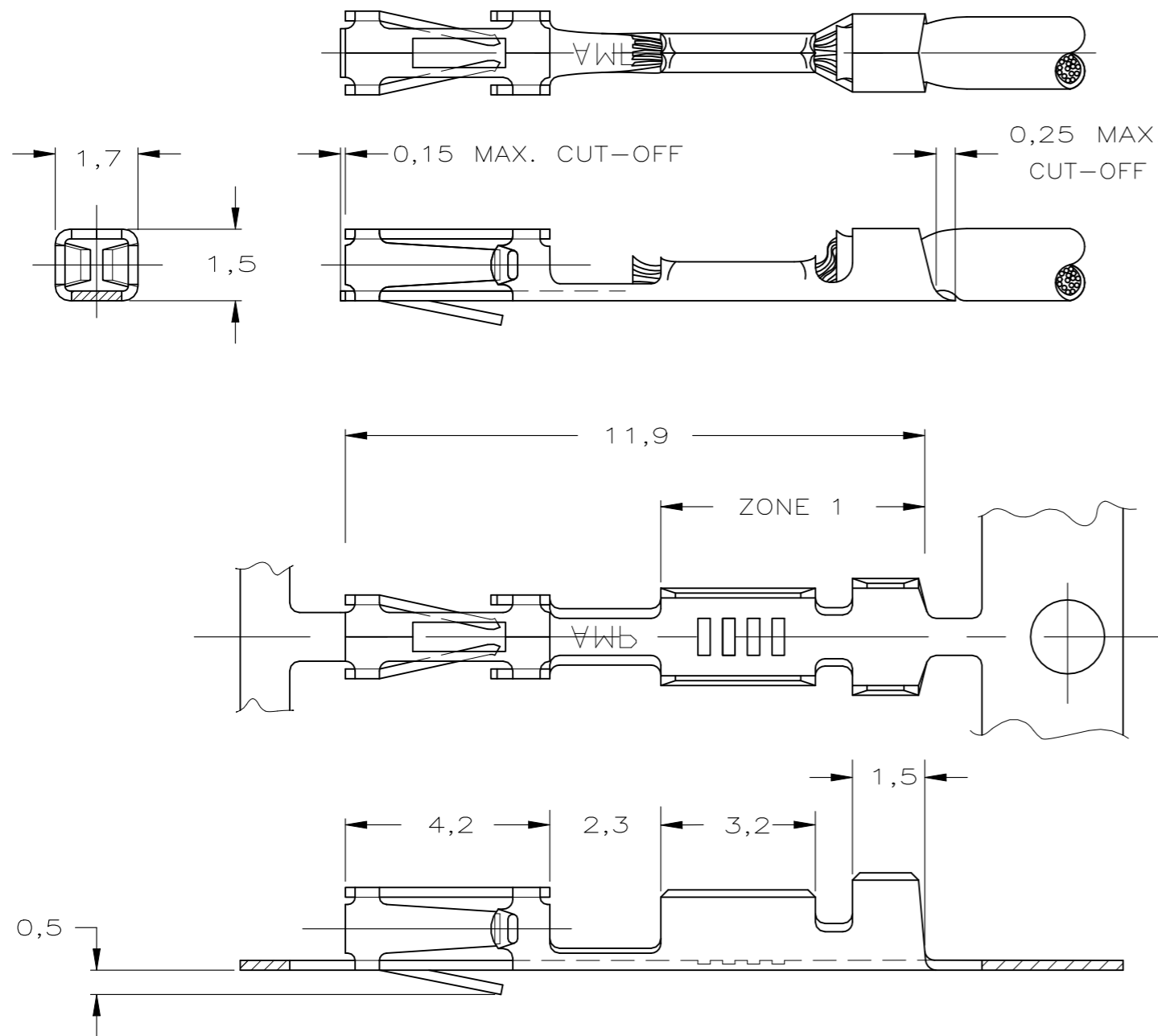

GOLD 2	141603-4	5-167300-8	8
GOLD 4	≠	1-167300-6	1
		1-167300-5	7
GOLD 2	141603-4	167300-8	1
		167300-7	7
GOLD 3	141603-3	167300-6	1
		167300-5	7
FINISH	LOOSE PIECE	PART NUMBER	

THIS DRAWING IS A CONTROLLED DOCUMENT.		DWN J.v.LIEMPT 03 DEC 98	TE Connectivity				
DIMENSIONS: mm		CHK J.v.LIEMPT					
TOLERANCES UNLESS OTHERWISE SPECIFIED: ±0.2mm		APVD E.LEIJTENS	NAME				
0 PLC ± - 1 PLC ± - 2 PLC ± - 3 PLC ± - 4 PLC ± - ANGLES ± -		PRODUCT SPEC 108-25020	AMPMODU MOD IV RECEPTACLE, STRIP				
MATERIAL 6		FINISH SEE TABLE	APPLICATION SPEC 114-25003	SIZE A3	CAGE CODE 00779	DRAWING NO C-167300	RESTRICTED TO -
CUSTOMER DRAWING			WEIGHT -	SCALE -	SHEET 1 OF 1	REV G	