

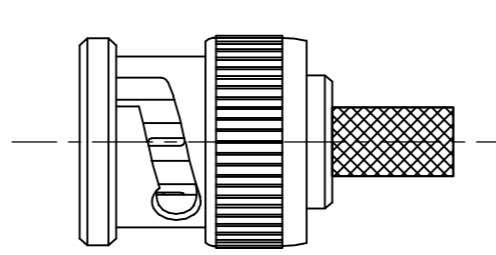
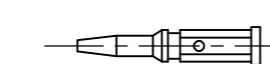
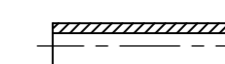
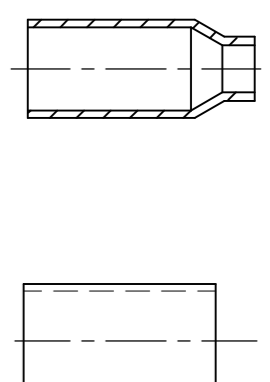

THIS DRAWING IS UNPUBLISHED. RELEASED FOR PUBLICATION JUNE ,2004.  
 © COPYRIGHT 2004 By - ALL RIGHTS RESERVED.

LOC	DIST	REVISIONS					
E	B	P	LTR	DESCRIPTION	DATE	DWN	APVD
		-		SEE SHEET 1	-	-	-

COMPONENTS

MAIN BODY (ITEM 1,3,4,6,7 & 8)	CENTRE CONTACT (ITEM 2)	PUSHER SLEEVE (ITEM 9)	CRIMP FERRULES (ITEM 5 & 10)
			

ASSEMBLY INSTRUCTION

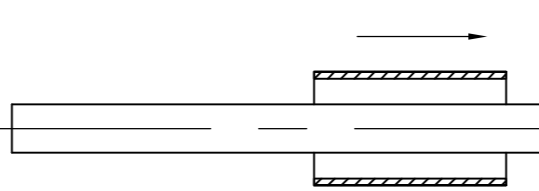
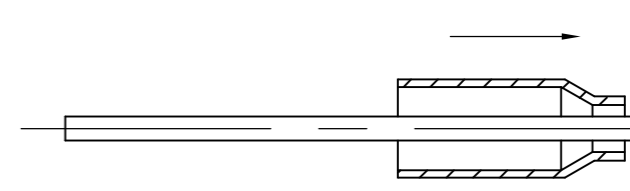
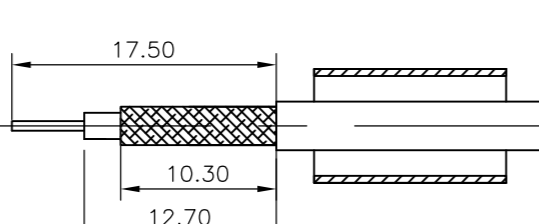
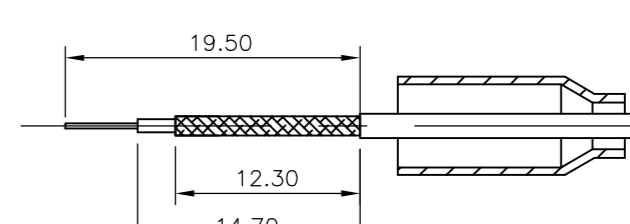
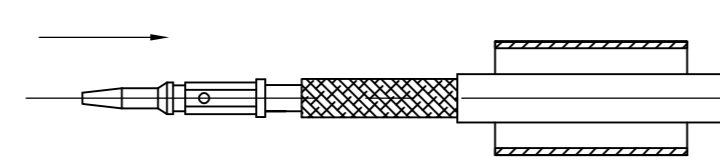
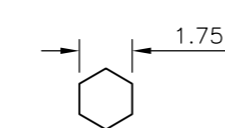
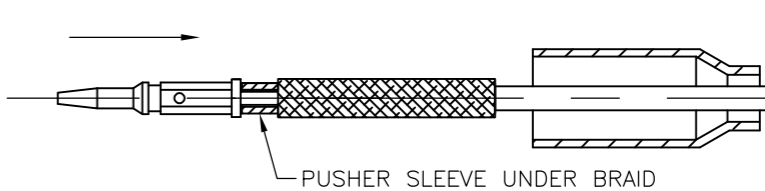
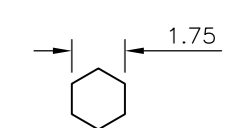
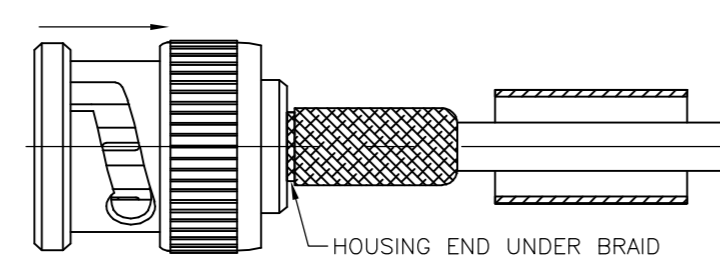
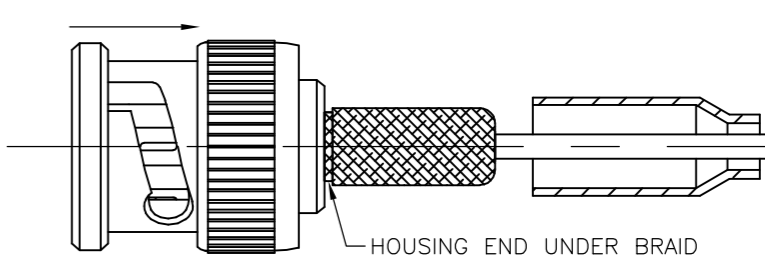
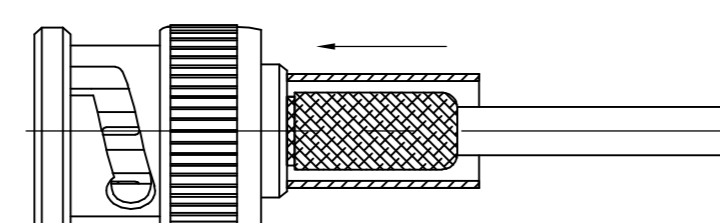
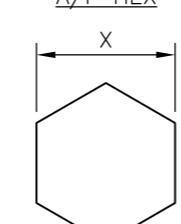
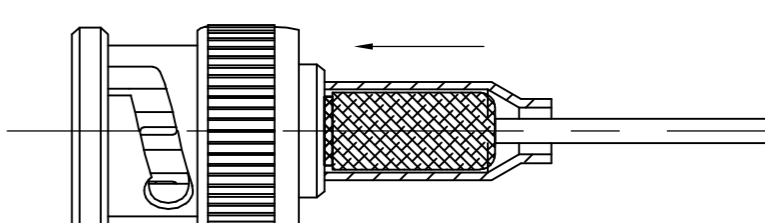
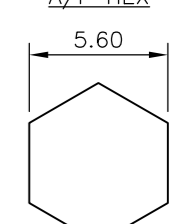
CABLES: RG59B/U, 62A/U, 140/U, 210/U, URM90, KX 6A, KX 25, KX 52, KX 53, RG58C/U, 141A/U, URM43, 76, BELDEN 9907, KX 15	CABLES: RG179B/U, 187A/U, URM111
<p><b>STEP 1</b></p> <p>1. SLIDE METAL CRIMP FERRULE OVER CABLE</p> 	<p><b>STEP 1</b></p> <p>1. SLIDE METAL CRIMP FERRULE OVER CABLE</p> 
<p><b>STEP 2</b></p> <p>1. STRIP CABLE TO DIMENSIONS AS SHOWN</p> 	<p><b>STEP 2</b></p> <p>1. STRIP CABLE TO DIMENSIONS AS SHOWN</p> 
<p><b>STEP 3</b></p> <p>1. FIT CONTACT OVER CENTRE CONDUCTOR TO BUTT AGAINST DIELECTRIC.            2. CRIMP USING TOOL AS NOTES ON PAGE 1.</p>  <p>RECOMMENDED CENTRE CONTACT A/F HEX</p> 	<p><b>STEP 3</b></p> <p>1. SLIDE ITEM 10 PUSHER SLEEVE OVER DIELECTRIC BEFORE FITTING THE CONTACT.            2. FIT CONTACT OVER CENTRE CONDUCTOR TO BUTT AGAINST DIELECTRIC.            3. CRIMP USING TOOL AS NOTES ON PAGE 1.</p>  <p>PUSHER SLEEVE UNDER BRAID</p> <p>RECOMMENDED CENTRE CONTACT A/F HEX</p> 
<p><b>STEP 4</b></p> <p>1. PRESS SUB-ASSEMBLY INTO BODY, UNTIL CONTACT IS FULLY LOCATED BY AN AUDIBLE CLICK.            2. ENSURE THAT KNURLED HOUSING INSERTS BETWEEN THE DIELECTRIC AND CABLE BRAID.</p>  <p>HOUSING END UNDER BRAID</p>	<p><b>STEP 4</b></p> <p>1. PRESS SUB-ASSEMBLY INTO BODY, UNTIL CONTACT IS FULLY LOCATED BY AN AUDIBLE CLICK.            2. ENSURE THAT KNURLED HOUSING INSERTS BETWEEN THE PUSHER SLEEVE AND CABLE BRAID.</p>  <p>HOUSING END UNDER BRAID</p>
<p><b>STEP 5</b></p> <p>1. SLIDE CRIMP FERRULE ALONG THE CABLE UNTIL IT BUTTS AGAINST THE HOUSING BODY.            2. CRIMP USING TOOL AS NOTED ON PAGE 1.            3. CRIMP DIMENSION X IS:-            RG59B (SEE PAGE 1 FOR FULL CABLE LIST) = 6.50            RG58C/U (SEE PAGE 1 FOR FULL CABLE LIST) = 5.60</p>  <p>RECOMMENDED CRIMP SLEEVE A/F HEX</p> 	<p><b>STEP 5</b></p> <p>1. SLIDE CRIMP FERRULE ALONG THE CABLE UNTIL IT BUTTS AGAINST THE BODY HOUSING.            2. CRIMP USING TOOL AS NOTED ON PAGE 1.            3. CRIMP DIMENSION AS SHOWN.</p>  <p>RECOMMENDED CRIMP SLEEVE A/F HEX</p> 

THIS DRAWING IS A CONTROLLED DOCUMENT.		DWN RITA ZUO 19 Feb 09		
DIMENSIONS: MM		CHK ANSON MA 19 Feb 09		
		APVD BOB ZHAO 19 Feb 09	NAME	
TOLERANCES UNLESS OTHERWISE SPECIFIED		PRODUCT SPEC 108-112000	BNC STRAIGHT PLUG HEX CRIMP 75 OHM	
MATERIAL SEE TABLE		FINISH SEE TABLE	APPLICATION SPEC SHEET 2	RESTRICTED TO
		WEIGHT -	SCALE A2 00779	DRAWING NO C=1634502
		CUSTOMER DRAWING	SCALE NTS	SHEET 2 of 2 REV E1

1634502

A