

D  
C  
B

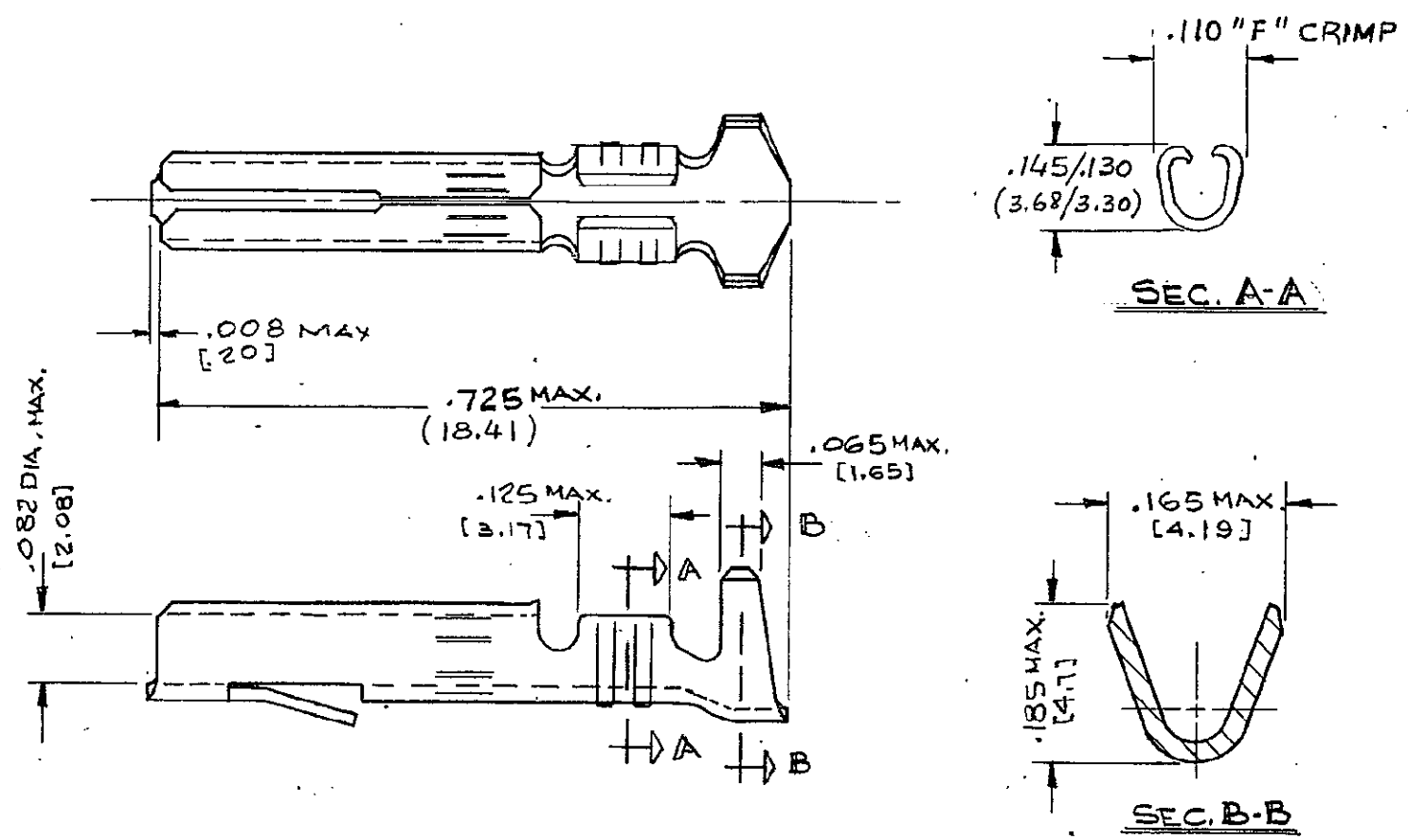

⚠ OBSOLETE

155487-2	TIN-PLATED ⚠	155468-2
155487-1	#	155468-1
STRIP NO. CINTA NO.	FINISH ACABADO	AMP PART NO. PIEZA NO.

PRINT DIST. DIMENSIONS IN INCHES - [MILLIMETERS] DO NOT SCALE PRINT. DIMENSIONES EN PULGADAS [MILIMETROS] NO USE ESCALAS DENTRO DEL DIBUJO

REVISION	DATE FECHA	BY CHK	DATE FECHA	REVISION	DATE FECHA	BY CHK	DATE FECHA
A	155487 WAS 60994 ADD. - Z	ECA	18-79				
B	ACTUALIZED INS. BARREL PRE-FORMED BARREL ADDED SWAGE IN LANCE CANCELLED	475	10-1 1979				
C	H.T. ADDED	522	16-X-80				
C1	REVISED PER ECR-21-101087		08MAY2021				

REQUIRED PER ASSEMBLY CANTIDADES POR ENSAMBLE	MATERIAL BRASS .0126 LATON [31]	HEAT TREAT TRATAMIENTO TERMICO STRESS RELIEF PER 111-86-2	COATING OR PLATING REVESTIMIENTO SEE TABLE VER TABLA
WIRE RANGE RANGO DE ALAMBRE 16-14	UNLESS OTHERWISE SPECIFIED A MENOS OTRAS ESPECIFICACIONES	REMOVE BURRS, BREAK SHARP EDGES 1/64 R. MAX. FRACTIONS: ± 1/64 DECIMALS: .000 = ± .005 .0000 = ± .0005 [0.00 = ± 0.13] ANGLES: ± 0° 30' QUITE LAS REBABAS Y LOS FILOS DE LOS BORDES FRACCIONES: ± 1/64 DECIMALES: .000 = ± .005 .0000 = ± .0005 [0.00 = ± 0.13] ANGULOS: ± 0° 30'	
AREA #	TYPE-TIPO MATE-N-LOCK	AMP de México, S. A.	
DR. DIB JORGE GUTIERREZ R.	FIRST USED PRIMER USO	LOC Q	NO. B 155468
CHK REV J. Villalobos 16-X-69	SCALE ESCALA 5:1	NAME NOMBRE MATE-N-LOCK SOCKET (L.P.) PIEZA SUELTA.	
APP APR C. C. 16-X-69	REL CED C. C. 16-X-69	DIBUJO PARA CLIENTES	