

THIS DRAWING IS UNPUBLISHED. RELEASED FOR PUBLICATION
 © COPYRIGHT - BY TYCO ELECTRONICS CORPORATION. ALL RIGHTS RESERVED.

LOC		DIST		REVISIONS			
P	LTR	DESCRIPTION	DATE	DWN	APVD		
B		REVISED PER ECO-16-000817	22JAN16	FL	SY		

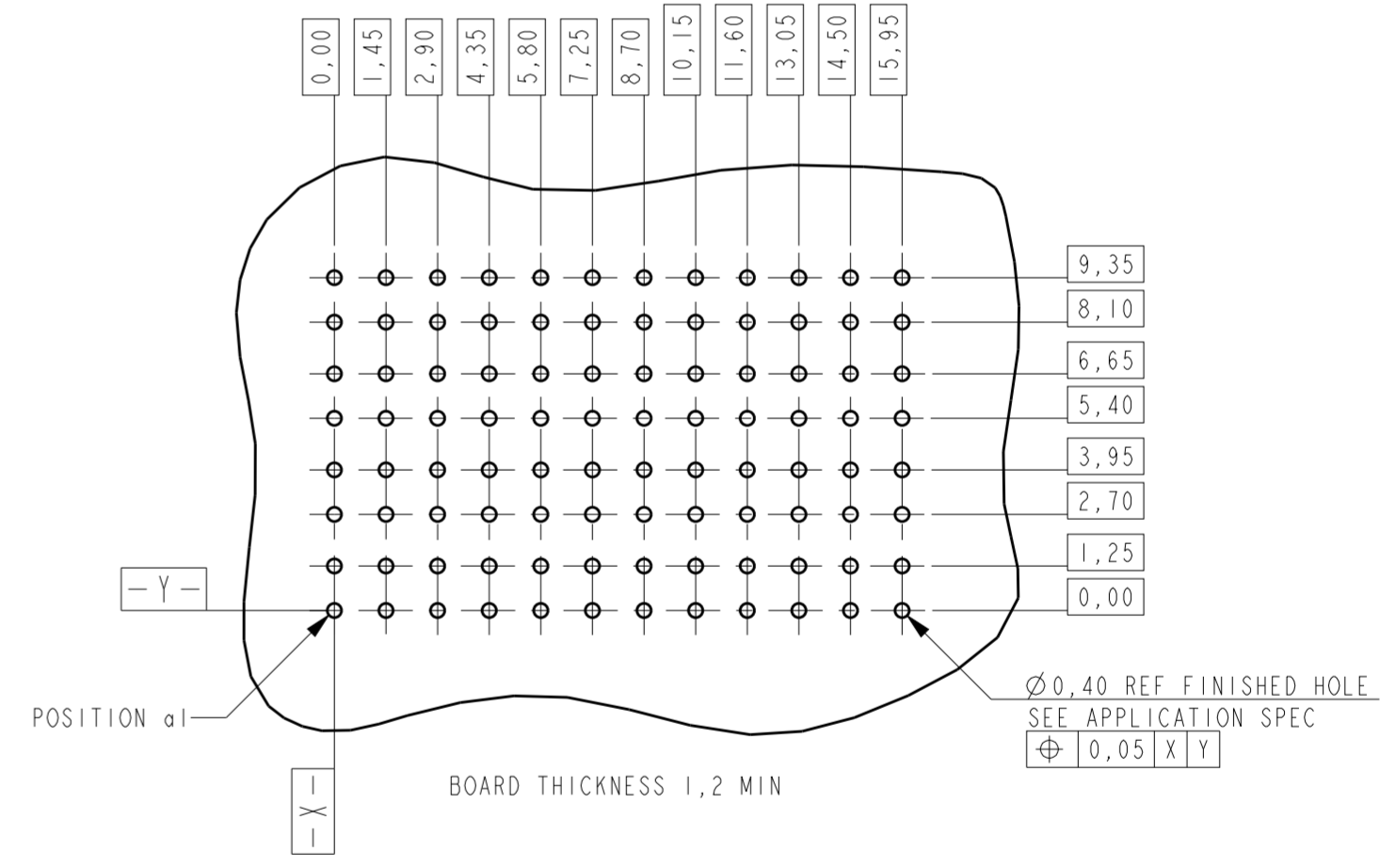
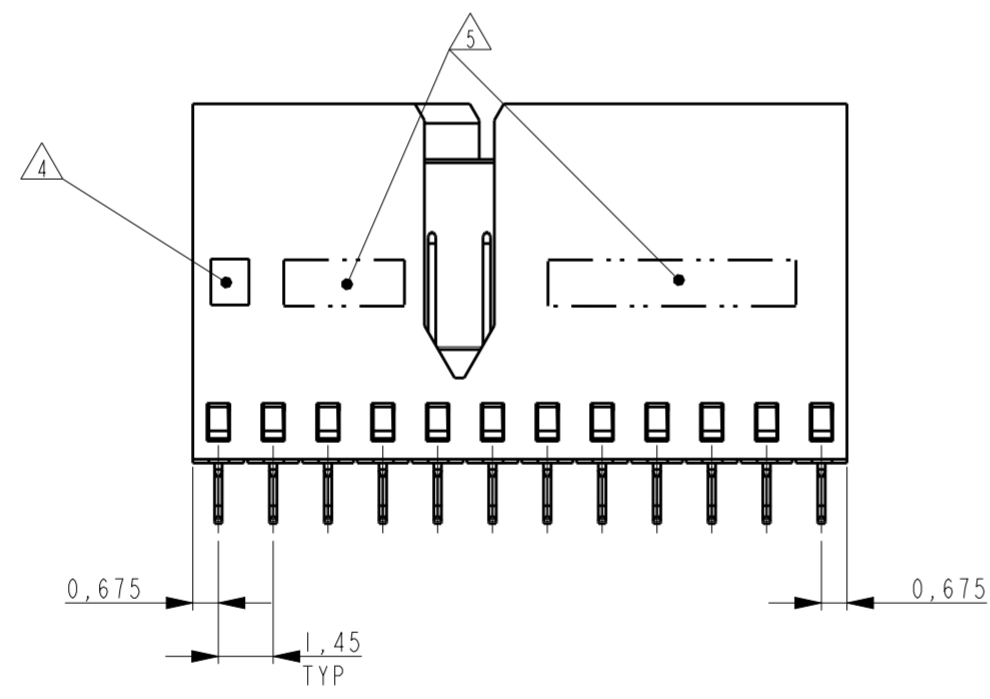
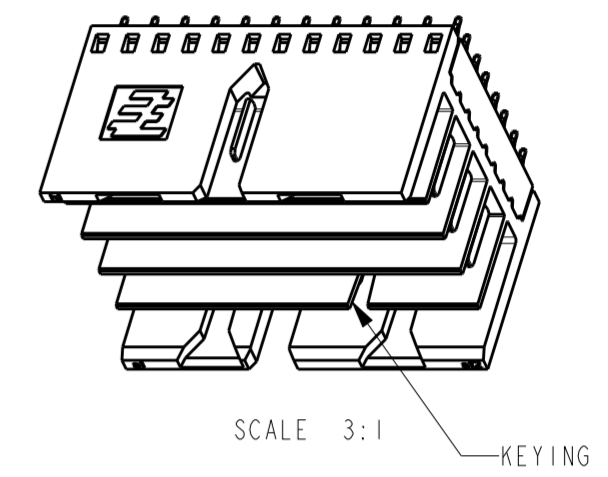
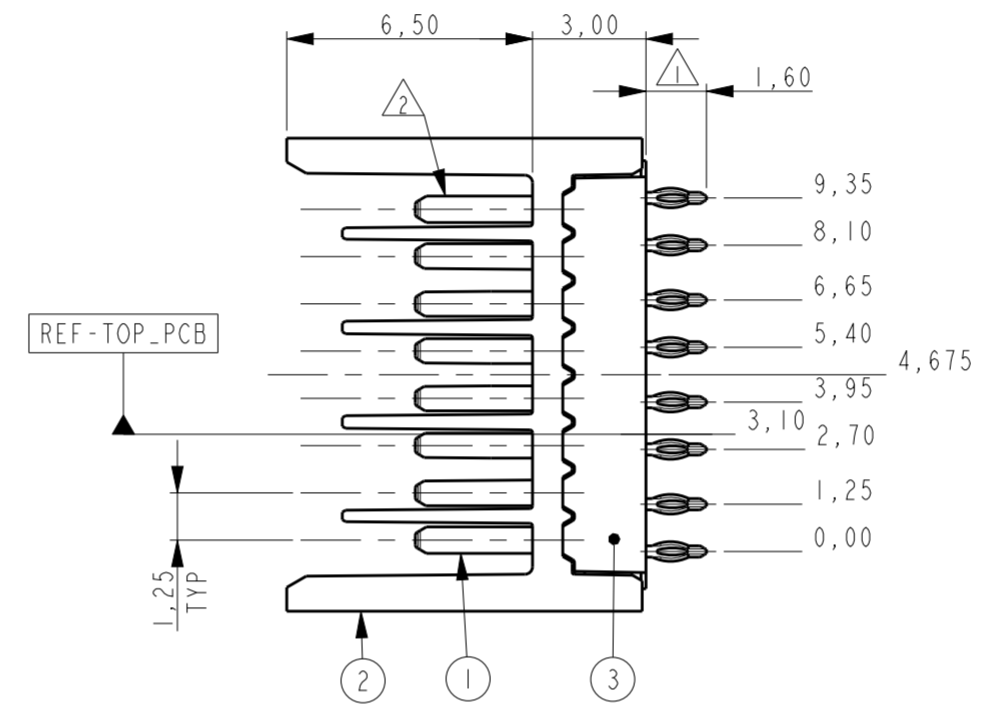
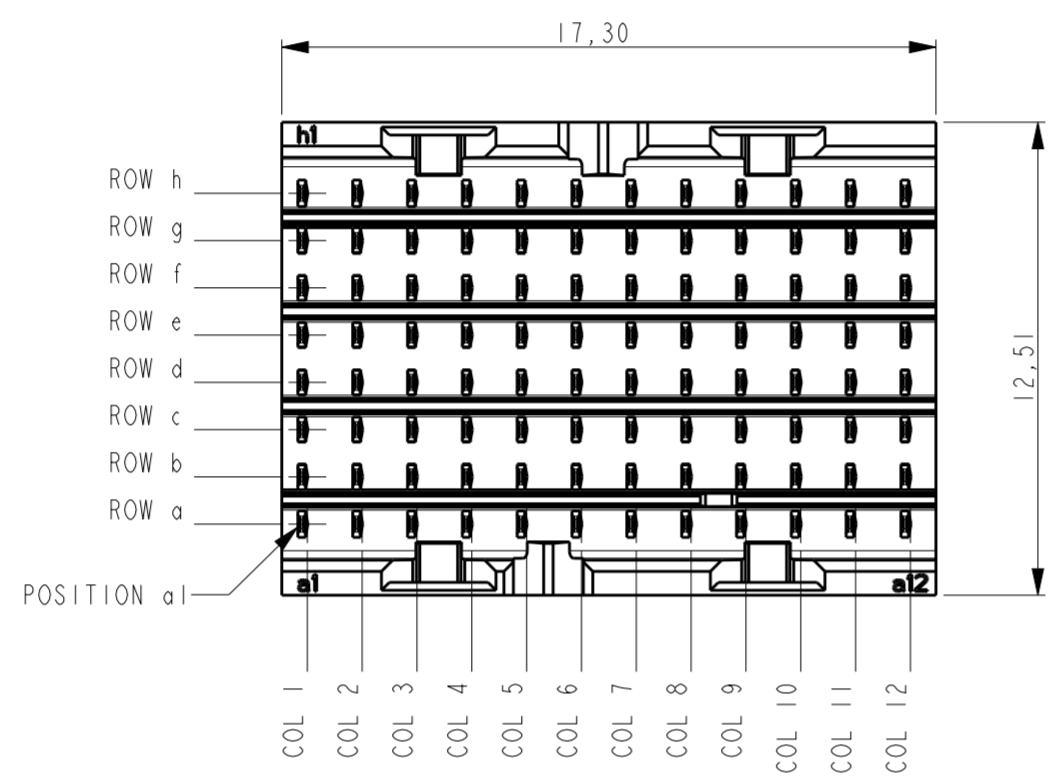
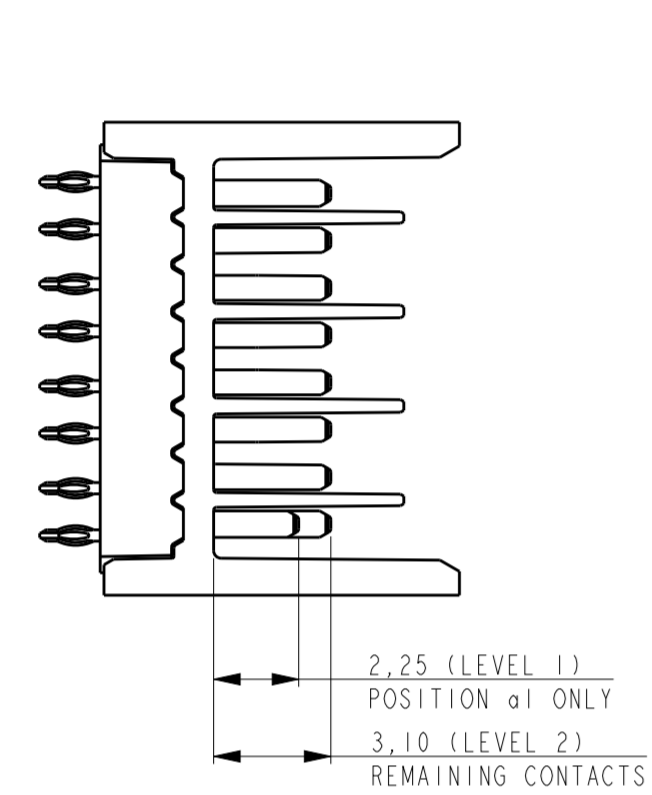
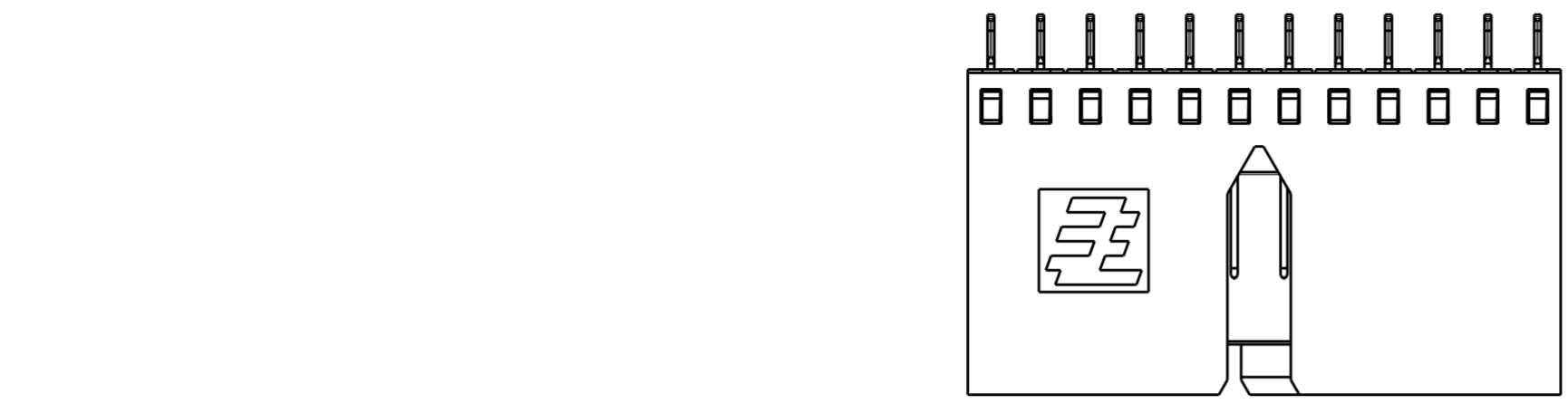

NOTES:

- ⚠ PLATING: 0,5µm MIN. TIN OVER NICKEL.
- ⚠ PLATING:

PARTNUMBER	PERFORMANCE LEVEL
1551013-1	PERFORMANCE LEVEL 1: CONNECTOR TESTED AND QUALIFIED AGAINST TELCORDIA GR-1217-CORE QUALITY LEVEL III: UNCONTROLLED ENVIRONMENT APPLICATIONS. SEE PRODUCT SPEC 108-19353
1551013-2	PERFORMANCE LEVEL 2: CONFORMS TO ALL TESTING ACCORDING PRODUCT SPEC 108-19320, -250 MATING CYCLES, 4 DAYS MIXED GAS TEST PER IEC 60068-2-60 METHOD 1

- 3 CONSULT APPLICATION SPEC OR CONTACT TE CONNECTIVITY FOR PERMISSIBLE CONTACT ASSIGNMENTS.
- ⚠ BLACK SQUARE MARKING FOR LEVEL 1 PIN AT POSITION a1 AS INDICATED.
- ⚠ CONNECTOR MARKED WITH PARTNUMBER AND DATE CODE.

THIS DRAWING IS A CONTROLLED DOCUMENT.

DIMENSIONS:	TOLERANCES UNLESS OTHERWISE SPECIFIED:
mm	0 PLC ±
	1 PLC ±
	2 PLC ±
	3 PLC ±
	4 PLC ±
	ANGLES ±
	FINISH ±

DWN	Vathsa	01 Dec 08
CHK	R Annakkee	01 Dec 08
APVD	Mark Westen	01 Dec 08
PRODUCT SPEC	SEE NOTE 2	
APPLICATION SPEC	114-19106	
WEIGHT	-	
CUSTOMER DRAWING		

3	OVERMOLD	LCP 30% GF NATURAL
2	HOUSING	LCP 30% GF NATURAL
1	CONTACT	COPPER ALLOY
ITEM NO.	DESCRIPTION	MATERIAL

STE TE Connectivity

NAME: MALE CONNECTOR Z-PACK Slim UHD

SIZE	CAGE CODE	DRAWING NO	RESTRICTED TO
A2	00779	C-1551013	-

SCALE: 5:1 SHEET 1 OF 1 REV B