

# PRODUCT SPECIFICATION

108-5614

## AMP Mini CT HYBRID DRAWER CONNECTOR

(1.5mm PITCH)

### 1. Scope :

#### 1.1 Contents

This specification covers the requirements for product performance, test methods and quality assurance provisions of AMP Mini CT Hybrid Drawer Connector. Applicable product description and part numbers are as shown in Fig.1.

### 2. Applicable Documents:

The following documents form a part of this specification to the extent specified herein. In the event of conflict between the requirements of this specification and the product drawing, the product drawing shall take precedence. In the event of conflict between the requirements of this specification and the referenced documents, this specification shall take precedence.

#### 2.1 AMP Specifications :

- A. 109-5000 Test Specification, General Requirements for Test Methods
- B. 114-5182 Application Specification
- C. 501-51021 Qualification Test Report

#### 2.2 Commercial Standards and specifications :

- A. MIL-STD-202 : Test Methods for Electronic and Electrical Component Parts.
- B. IEC : International Electrotechnical Commission

### 3. Requirements :

#### 3.1 Design and Construction :

Product shall be of the design, construction and physical dimensions specified on the applicable product drawing.

ON CONDITION THAT NO FURTHER DISCLOSURE IS MADE BY YOU TO OTHER THAN AMP PERSONNEL WITHOUT WRITTEN AUTHORIZATION FROM AMP MANUFACTURING SINGAPORE PTE LTD

				DR	WL CHOO	 AMP MANUFACTURING (SINGAPORE) PTE LTD 26 ANG MO KIO INDUSTRIAL PARK 2 SINGAPORE 2056 TEL : 4820311 (20 LINES) FAX NO. 65-4821012			
D	Revised FP00-0371-01	Top	17/9/01	CHK	J. TANIGAWA				
C	Revised FP00-0139-01	TLP	17/4/01	APP	SEE LAST PAGE				
B	Revised FP00-0104-00	CWL	30/6/00			NO	108-5614	REV	LOC
A	Revised FJ00-2060-99	T.Y.	29/11/99	PAGE	TITLE			D	DY
O	RELEASEDFJ00-1107-99	S.K.	28/6/99	1 OF 12	AMP Mini CT Hybrid Drawer Connector (1.5mm Pitch)				
LTR	REVISION RECORD	APP	DATE						

### 3.2 Materials :

#### 3.2.1 Plug Assembly

##### A. Signal Contact

Material: Phosphor Bronze

Finish (Mini CT post area):

1 $\mu$ m min. Tin-lead over 2-5 $\mu$ m Nickel underplate.

Finish (Drawer mating area):

i) 0.5 $\mu$ m min. Gold over 2-5 $\mu$ m Nickel underplate, or

ii) 0.05 $\mu$ m min. Gold over 0.5 $\mu$ m Palladium-Nickel over 2-5 $\mu$ m Nickel underplate.

##### B. Power Contact

Material: Brass

Finish: (Gold version)

0.38 $\mu$ m min. Gold (mating area), 1 $\mu$ m min. Tin-lead (crimp area) over 0.5-5 $\mu$ m Nickel underplate.

Finish: (Tin version)

Pre-plated Tin 0.8 $\mu$ m min.

##### C. Housing

Material: Glass-filled PBT UL94V-0

#### 3.2.2 Receptacle Assembly

##### A. Signal Contact

Material: Brass

Finish (Mini CT post area):

1 $\mu$ m min. Tin-lead over 2-5 $\mu$ m Nickel underplate.

Finish (Drawer mating area):

i) 0.5 $\mu$ m min. Gold over 2-5 $\mu$ m Nickel underplate, or

ii) 0.05 $\mu$ m min. Gold over 0.5 $\mu$ m Palladium-Nickel over 2-5 $\mu$ m Nickel underplate.

##### B. Power Contact

Material: Phosphor Bronze

Finish: (Gold version)

0.38 $\mu$ m min. Gold (mating area), 1 $\mu$ m min. Tin-lead (crimp area) over 0.5-5 $\mu$ m Nickel underplate.

Finish: (Tin version)

Pre-plated Tin 0.8 $\mu$ m min.

##### C. Housing

Material: Glass-filled PBT UL94V-0

3.3 Ratings :

A. Voltage Rating (Signal): 50 VAC/DC  
Voltage Rating (Power): 250 VAC

B. Current Rating(Signal): 1A Max.  
Current Rating(Power):

- AWG # 16 (1.25 mm<sup>2</sup>): 12A
- AWG # 18 (0.85 mm<sup>2</sup>): 10A
- AWG # 20 (0.5 mm<sup>2</sup>): 7A
- AWG # 22 (0.3 mm<sup>2</sup>): 5A
- AWG # 24 (0.2 mm<sup>2</sup>): 4A

C. Temperature Rating : -30°C to +105°C

The upper limit of temperature rating includes the temperature rise resulted from energized electrical current.

3.4 Performance Requirements and Test Descriptions :

The product shall be designed to meet the electrical, mechanical and environmental performance requirements specified in Fig. 2.

All tests shall be performed in the room temperature, unless otherwise specified.

Product Part No.	Description
x-1123347-x x-1318147-x	Plug Assembly, 1.5mm Pitch Mini CT Hybrid Drawer Connector.
x-1123349-x x-1318149-x	Receptacle Assembly, 1.5mm Pitch Mini CT Hybrid Drawer Connector.
x-84683-x	Plug Assembly, 1.5mm Pitch Mini CT SF Hybrid Drawer Connector.
x-84684-x x-84717-x	Receptacle Assembly, 1.5mm Pitch Mini CT SF Hybrid Drawer Connector.
x-179316-x x-179333-x	Power Receptacle Contact (#20 - #16 AWG)
x-179317-x x-179334-x	Power Receptacle Contact (#24 - #20 AWG)
x-316458-x	Ground Receptacle Contact (#20 - #16 AWG)
x-179321-x x-179335-x	Power Tab Contact (#20 - #16 AWG)
x-179322-x x-179336-x	Power Tab Contact (#24 - #20 AWG)

Fig. 1

	AMP MANUFACTURING SINGAPORE PTE LTD No. 26, Ang Mo Kio Industrial Park 2, Singapore 2056	Page	NO	REV	LOC
		3	108-5614	D	DY

3.5 Test Requirements and Procedures Summary:

Para.	Test Items	Requirements	Procedures
3.5.1	Examination of Product	Meets requirements of product drawing.	Visual inspection No physical damage
<b>Electrical Requirements</b>			
3.5.2	Termination Resistance (Low Level)	Signal Line: 30mΩ Max. (Initial) 40mΩ Max. (Final) Power Line: 6mΩ Max. (Initial) 10mΩ Max. (Final)	Subject mated connectors to 20 mV Max open circuit at 10 mA Refer Fig.4.
3.5.3	Dielectric withstanding Voltage	No creeping discharge nor flashover shall occur.  Current leakage : Signal Line 5mA Max. Power Line 1mA Max.	Signal Line: 500 VAC for 1 minute. Power Line: 1.8 kVAC for 1 minute.  Test between adjacent circuits of mated connectors. MIL STD 202 TEST METHOD 301 IEC 512-2 TEST 4A
3.5.4	Insulation Resistance	500 MΩ Min. (Initial) 100 MΩ Min. (Final)	Apply voltage 500 VDC for 1 minute. Test between adjacent circuits of mated connectors. MIL STD 202 TEST METHOD 302 CONDITION B
3.5.5	Temperature Rise	30 °C Max. under loaded rating current.	Contacts series-wired, apply rated current to the circuit, and measure the temperature rise, after the temperature becomes stabilized. Deduct ambient temperature from the measured value.

Fig.2 (To be continued)

Para.	Test Items	Requirements			Procedures	
<b>Mechanical Requirements</b>						
3.5.6	Crimp Tensile Strength (Power contacts only)	Wire Size		Crimp Tensile (Min)		Apply an axial pull-of load to a crimped wire, with the contact secured to the tester. Operation Speed: 100 mm/min.
		mm <sup>2</sup>	AWG	N	kgf	
		0.2	#24	19.6	2.0	
		0.3	#22	34.3	3.5	
		0.5	#20	45.1	4.6	
		0.85	#18	98.0	10.0	
		1.25	#16	186.2	19.0	
3.5.7	Contact-housing Insertion Force (Power contacts only)	14.7 N(1.5 kgf) Max. per contact.			Measure force required to insert contact into housing.	
3.5.8	Contact Retention Force	Signal Contact: 14.7 N(1.5 kgf) Min., in direction of mating with Mini CT Receptacle. Power Contact: 58.9N (6.0 kgf) Min.			Measure contact retention force. Operation Speed : 100 mm/min.	
3.5.9	Connector Mating Force	Pos. size (Power/Signal)	Initial	After Durability	Operation Speed : 100 mm/min. Measure the force required to mate connectors.	
		4/12	40.2N (4.1kgf) Max.	60.8N (6.2kgf) Max.		

Fig.2 (To be continued)

Para.	Test Items	Requirements		Procedures
3.5.10	Connector Unmating Force	Pos. size (Power/Signal)	Initial & After Durability Min.	Operation Speed : 100 mm/min. Measure the force required to unmate connectors.
		4/12	6.5N (0.66kgf)	
3.5.11	Panel Retention Force (For Snap-Fit only)	98 N (10 kgf) Min.		Measure panel retention fore using panel of nominal cut-out dimensions as specified in the AMP Customer Drawing. Loading is made from the direction opposite to connector insertion direction.
3.5.12	Durability (Repeated Mating & Unmating)	Signal Line: 40 mΩ Max. (Final) Power Line: 10 mΩ Max. (Final)		Operation Speed : 100 mm/min. No. of Cycles : Gold version: 3000 cycles Pre-tin version: 30 cycles.
3.5.13	Vibration (Low Frequency)	No electrical discontinuity greater than 1 μsec. shall occur. Signal Line: 40 mΩ Max. (Final) Power Line: 10 mΩ Max. (Final)		Subject mated connectors to 10-55-10 Hz traversed in 1 minute at 1.52 mm amplitude 2 hours each of 3 mutually perpendicular planes. MIL-STD-202 TEST METHOD 201 CONDITION A Mounting : Fig. 5

Fig.2 (To be continued)

<b>AMP</b>	AMP MANUFACTURING SINGAPORE PTE LTD No. 26, Ang Mo Kio Industrial Park 2, Singapore 2056	Page	NO	REV	LOC
		6	108-5614	D	DY

Para.	Test Items	Requirements	Procedures
3.5.14	Physical Shock	No electrical discontinuity greater than 1µsec. shall occur. Signal Line: 40 mΩ Max. (Final) Power Line: 10 mΩ Max. (Final)	Accelerated Velocity: 490 m/s <sup>2</sup> (50G) Waveform: halfsine shock pulse Duration: 11 msec. Number of shocks: 3 shocks in each direction applied along the X, Y and Z axes, totally 18 shocks. MIL-STD-202 TEST METHOD 213 CONDITION A IEC 68-2-27, Test Ea Mounting : Fig. 5
3.5.15	Hammering Shock	No electrical discontinuity greater than 1µsec. Shall occur. Signal Line: 40 mΩ Max. (Final) Power Line: 10 mΩ Max. (Final)	Subject mated connectors to 10,000 cycles of hammering shocks in set-up as shown in Fig. 6, with test current of 1mA at DC 10V applied to circuits as shown in Fig. 7. During the test, the circuit shall be monitored for fluctuation of electrical resistance.
<b>Environmental Requirements</b>			
3.5.16	Thermal Shock	Signal Line: 40 mΩ Max. (Final) Power Line: 10 mΩ Max. (Final)	Subject mated connectors to -55°C / 30 min., +85°C / 30 min. This being 1 cycle, repeat for a total of 25 cycles. MIL-STD-202 TEST METHOD 107

Fig.2 (To be continued)

<b>AMP</b>	AMP MANUFACTURING SINGAPORE PTE LTD No. 26, Ang Mo Kio Industrial Park 2, Singapore 2056	Page	NO	REV	LOC
		7	108-5614	D	DY

Para.	Test Items	Requirements	Procedures
3.5.17	Humidity-Temperature Cycling	Insulation resistance 100 MΩ Min.(Final) Termination resistance Signal Line: 40 mΩ Max. (Final) Power Line: 10 mΩ Max. (Final)	Subject mated connectors to 25~65°C, 90~95% R.H., 10 cycles. With cold shock -10°C. Re-condition in room temperature for 3Hrs before subsequent measurements. MIL-STD-202 TEST METHOD 106 IEC 68-2-38, Test Z/AD.
3.5.18	Salt Spray	Signal Line: 40 mΩ Max. (Final) Power Line: 10 mΩ Max. (Final)	Subject mated connectors to 5 ± 1% salt concentration for 48 hours. After test, rinse samples with water and recondition to room temperature for 1 hour before subsequent measurements. MIL-STD-202 TEST METHOD 101, CONDITION B. IEC 68-2-11, Test Ka.
3.5.19	Temperature Life (Heat Aging)	Signal Line: 40 mΩ Max. (Final) Power Line: 10 mΩ Max. (Final)	Subject mated connectors to 85± 2°C, 500 hours. MIL-STD-202 TEST METHOD 108.

Fig.2 (End)



#### 4. Product Qualification Test Sequence

Test Examination	/Test Group														
	1	2	3	4	5	6	7	8	9	10	11	12	13	14	15
	/Test Sequence (a)														
Examination of Product	1,4,8	1,3	1,3	1,3	1,3	1,3	1,3	1,3	1,5	1,5	1,5	1,5	1,5	1,5	1,5
Termination Resistance (Low Level)	2,5								2,4	2,4	2,4	2,4	2,4	2,4	2,4
Dielectric withstanding Voltage	7														
Insulation Resistance	6														
Temperature Rise		2													
Crimp Tensile Strength			2												
Contact-housing Insertion Force				2											
Contact Retention Force					2										
Connector Mating Force						2									
Connector Unmating Force							2								
Panel Retention Force								2							
Durability Cycling									3						
Vibration (Low Frequency)										3					
Physical Shock											3				
Hammering Shock												3			
Thermal Shock													3		
Humidity-Temperature Cycling	3														
Salt Spray														3	
Temperature Life (Heat Aging)															3

(a) /Numbers indicate sequence in which the tests are performed.

Fig.3

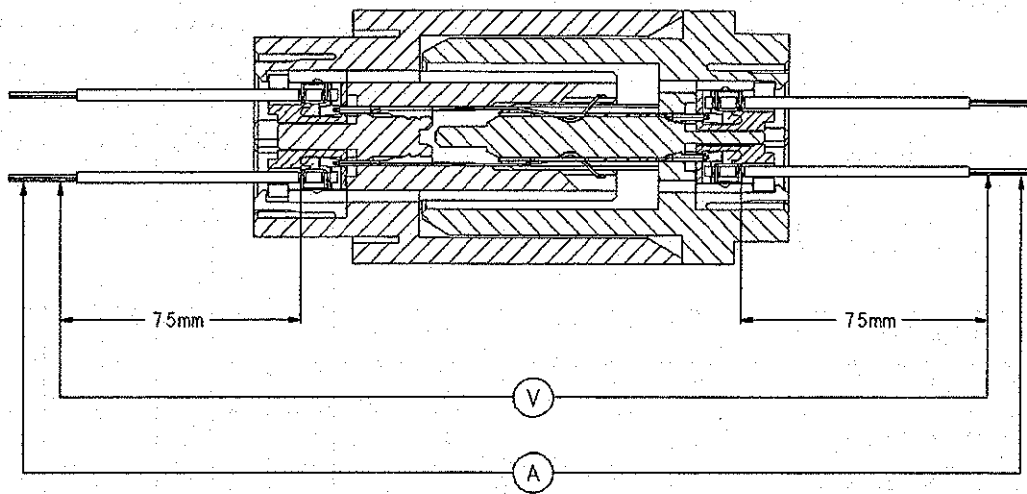

Fig. 4a: Signal Line Termination Resistance Measurement Method

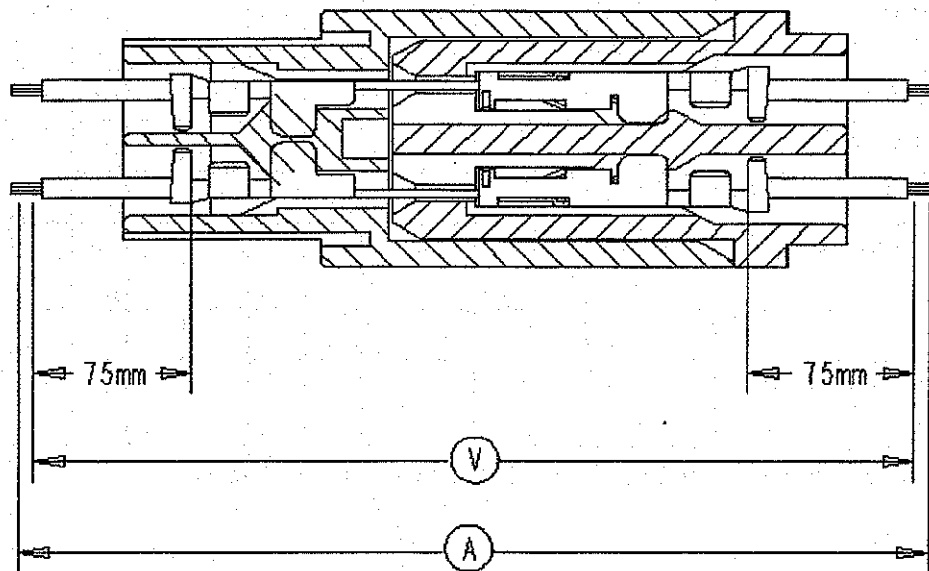

Fig. 4b: Power Line Termination Resistance Measurement Method

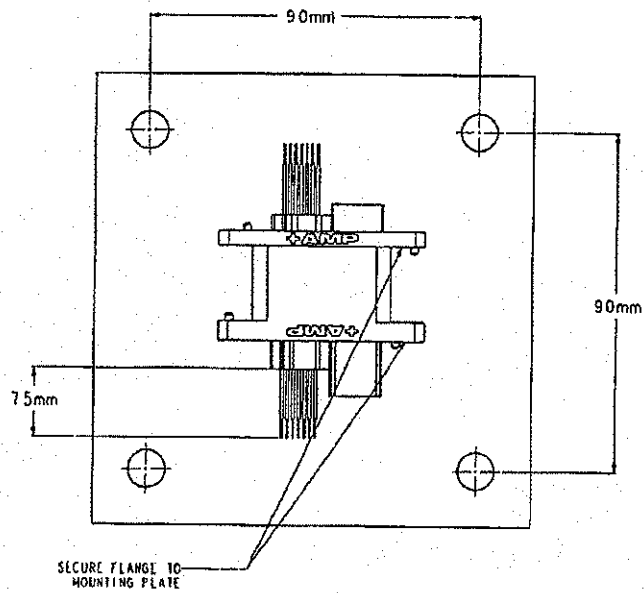

Fig. 5: Vibration/Physical Shock Mounting Method

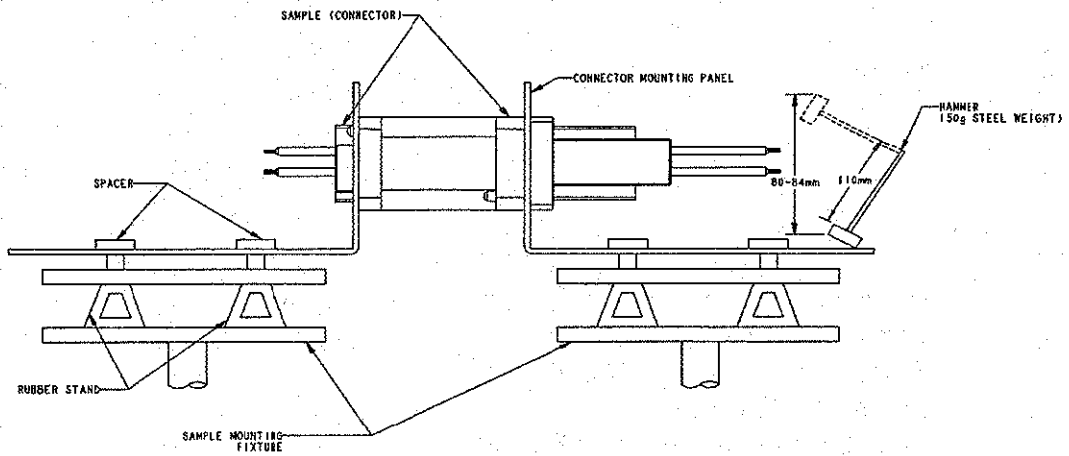

Fig. 6: Hammering Shock Test

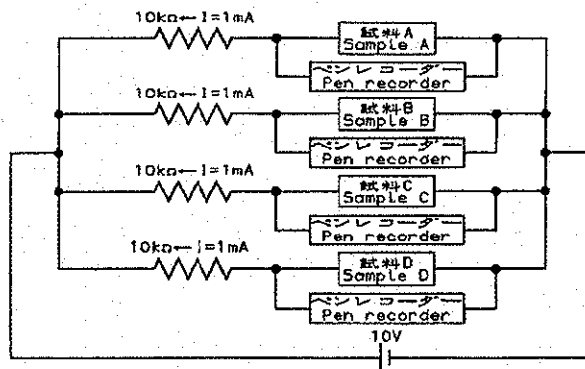

Fig. 7: Electrical Resistance Fluctuation Monitoring Circuit

5. VALIDATIONS

Prepared by:

L. P. TAN 17/9/01

Tan Lay Peng  
Product Engineer  
Product Engineering  
Tyco Electronics Singapore Pte. Ltd.

Reviwed by:

[Signature] 20 SEP '01

Choo Wing Lian  
Product Engineering Manager  
Product Engineering  
Tyco Electronics Singapore Pte. Ltd.

Approved by:

Sf. Leong 20 SEP '01

Leong See Fan  
Product Engineering Division Manager  
Product Engineering  
Tyco Electronics Singapore Pte. Ltd