

DESIGNED FOR USE WITH .085 S.R.	
CABLE ENTRY DIAMETER MINIMUM	
HOUSING	.088
CONTACT	.021

REVISIONS			
REV	DESCRIPTION	DATE	APPROVED
04 ₂	REVISED	8/16/69	<i>[Signature]</i>

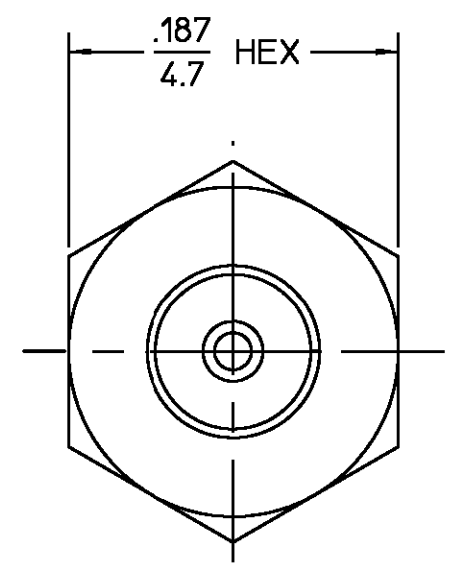
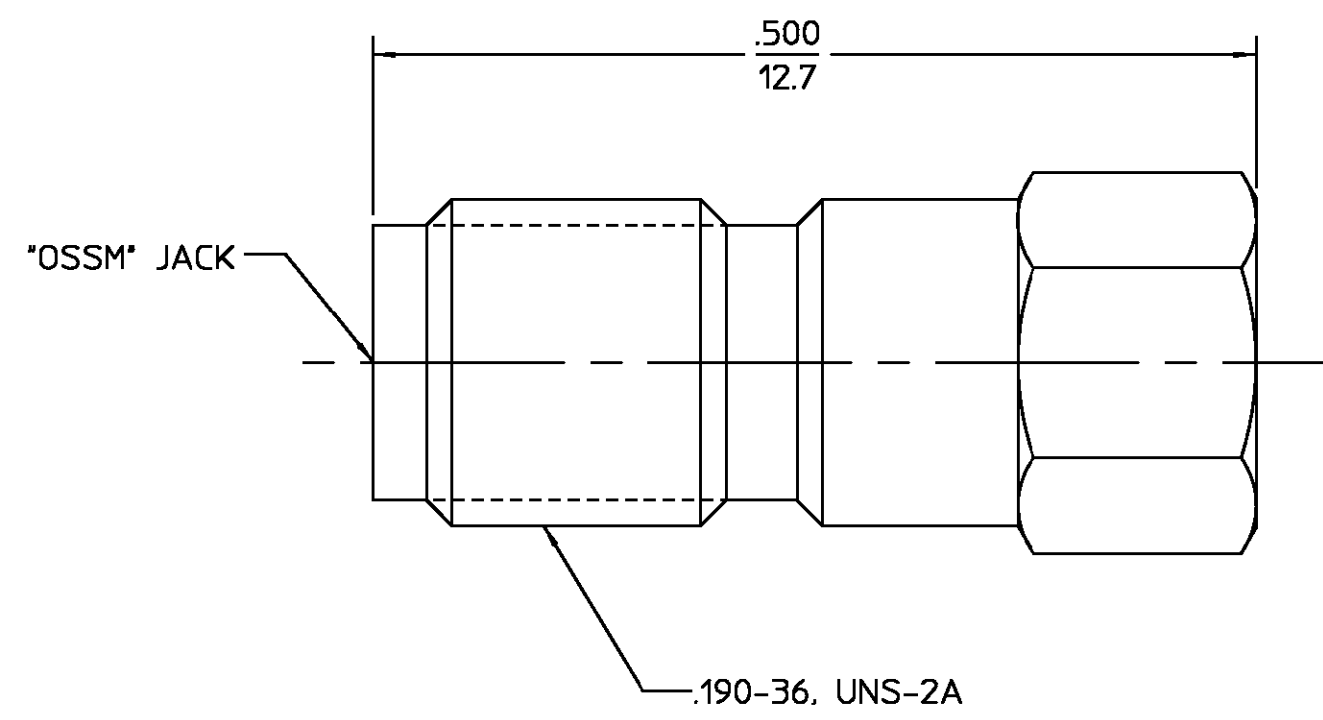

HOUSING	STAINLESS STEEL PER ASTM-A484 AND ASTM- A582, TYPE 303	GOLD PLATE PER MIL-G-45204
DIELECTRIC	TFE FLUOROCARBON PER ASTM-D-1457	N/A
CENTER CONTACT	BERYLLIUM COPPER PER ASTM-B-196 OR ASTM-B-197, ALLOY C17300, CONDITION H	GOLD PLATE PER MIL-G-45204
COMPONENT	MATERIAL	FINISH

UNLESS OTHERWISE SPECIFIED DIMENSIONS ARE IN INCHES	DRAWN BY EJC	DATE 7/29/69	AMP AMP Incorporated 140 Fourth Avenue Waltham, MA 02451-7599
	CHECKED BY PRB	7/29/69	
	APPD BY BWC	8/16/69	

These drawings and specifications are the property of M/A COM Interconnect Div. and shall not be reproduced or copied or used in whole or in part as the basis for the manufacture or sale of item(s) without written permission.	USE ASSY PROCEDURE	TITLE "OSSM" STRAIGHT CABLE JACK - DIRECT SOLDER ATTACHMENT		
	NO. A.P. 10-004 (408-04794)	SIZE B	CODE IDENT NO. 26805	1002-7985-00
		SCALE 10:1		REV 04 ₂
				SHEET 1 OF 1

.XXX = in
XX.X = mm (REF)