

# OPERATION MANUAL MODEL 3038 ACCELEROMETER

---



### WARRANTY

Measurement Specialties, Inc. accelerometers are warranted during a period of one year from date of shipment to original purchaser to be free from defects in material and workmanship. The liability of Seller under this warranty is limited to replacing or repairing any instrument or component thereof which is returned by Buyer, at his expense, during such period and which has not been subjected to misuse, neglect, improper installation, repair, alteration, or accident. Seller shall have the right to final determination as to the existence and cause of a defect. In no event shall Seller be liable for collateral or consequential damages. This warrant is in lieu of any other warranty, expressed, implied, or statutory; and no agreement extending or modifying it will be binding upon Seller unless in writing and signed by a duly authorized officer.

### RECEIVING INSPECTION

Every Measurement Specialties, Inc. accelerometer is carefully inspected and is in perfect working condition at the time of shipment. Each accelerometer should be checked as soon as it is received. If the unit is damaged in any way, or fails to operate, a claim should immediately be filed with the transportation company.

### SERVICE CONCERNS

If a Measurement Specialties, Inc. instrument requires service, first contact the nearest Measurement Specialties, Inc. representative. They may be able to solve the problem without returning the unit to the factory. If it is determined that factory service is required, call Customer Service at the regional headquarters for an RMA number before return.

### RETURNS

All units being returned to the factory require an RMA (Return Material Authorization) number before they will be accepted. This number may be obtained by calling Customer Service at the regional headquarters with the following information; model number(s), quantity, serial number(s), and symptoms of the problem, if being returned for service. You must include the original purchase order number if under warranty.

### RECALIBRATION SERVICES

The Vibration Sensors Design Center and its two manufacturing facilities in China and France offer factory re-calibration services for Piezoresistive, Piezoelectric and Integrated Electronics Piezoelectric (IEPE, ISOTRON, ICP, etc.) accelerometers. NIST (US), DKD (Germany), COFRAC (France) traceable calibration services on sensitivity at 100 Hz (102 or 120 Hz in Europe) and full frequency sweeps are offered. Contact the regional headquarters for pricing information.

# MODEL 3038 ACCELEROMETER

## DESCRIPTION

The Model 3038 is a silicon MEMS piezo-resistive accelerometer designed to be mounted on circuit boards. The accelerometer is ideal for embedded applications and is packaged in a hermetic ceramic LCC package and sealed with a gold-plated Kovar lid (100% gross leak testing is performed in production). The Model 3038 provides a millivolt output signal and features mechanical overload stops that provide shock protection to 10,000g. The accelerometer is offered in ranges from  $\pm 50g$  to  $\pm 6000g$  with a flat response up to greater than 5000Hz.

## INSTALLATION

The model 3038 accelerometer is designed to be soldered to printed circuit boards or hybrid substrates. It is critical that the substrate has a low coefficient of expansion and that you have good mechanical coupling between the sensor and the mounting surface to ensure good transmissibility. Ceramic circuit boards are preferred but FR4 boards can also be used with a suggested thickness of 0.062" (1.57mm). It is recommended to reflow solder the model 3038 accelerometer but it can also be manually soldered in cases where reflow soldering is not practical. For reflow soldering the following guidelines should be followed.

- Design the mounting pads on the circuit board according to the recommended dimensions below.
- Use a suitable RMA flux coated solder paste.
- A recommended stencil thickness is .008" (0.2mm).
- Secure the accelerometer during reflow soldering to ensure proper vertical alignment.
- Use of inert N2 gas is recommended.

Don't electrically connect to undesigantated pads but they are suitable for additional mechanical support.

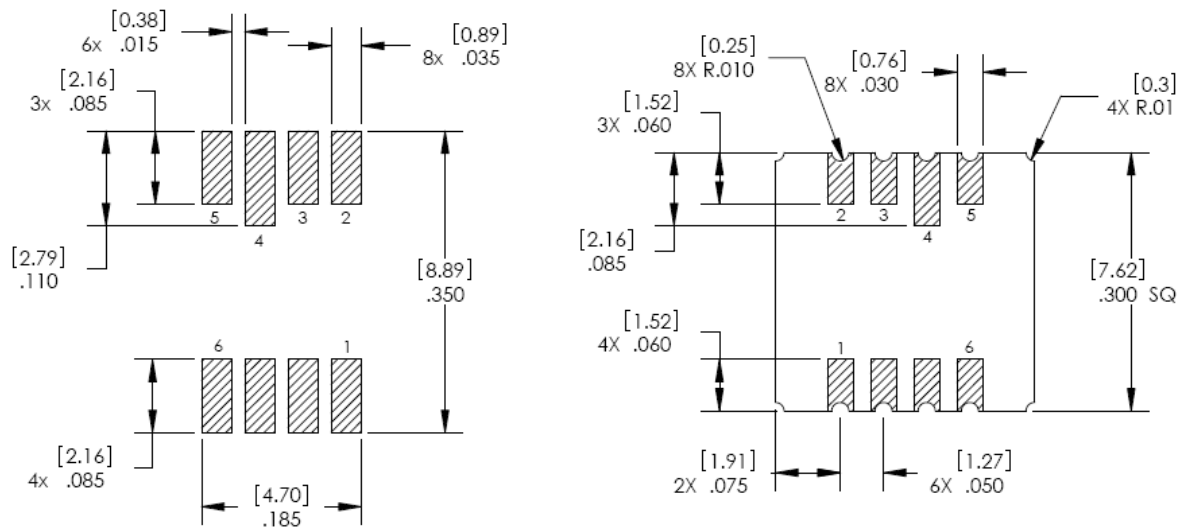

CIRCUIT BOARD PADS

MODEL 3038 ACCELEROMETER

DIMENSIONS ARE IN INCHES [mm]

## MODEL 3038 ACCELEROMETER

The following table defines recommended solder reflow profiles for common Eutectic and Lead-Free solders. However, it is always recommended to consult with the solder paste manufacturer for the proper profile.

Profile Feature	SnPb Eutectic	SnAgCu Lead-Free
Ramp-up Rate	1.0-3.0 °C/sec	1.0-3.0 °C/sec
Preheat (soak)		
Temperature Min (TSMIN)	Consult solder paste manufacturer recommended profile	Consult solder paste manufacturer recommended profile
Temperature Max (TSMAX)		
Time (tsMIN to tsMAX)		
Time Above Liquidus Temp (TAL)		
Temperature (TL)	30-90 sec	30-90 sec
Time (tL)		
Peak Temperature (TP)	205-220 °C	235-245 °C
Ramp-down Rate	4 °C/sec max	4 °C/sec max

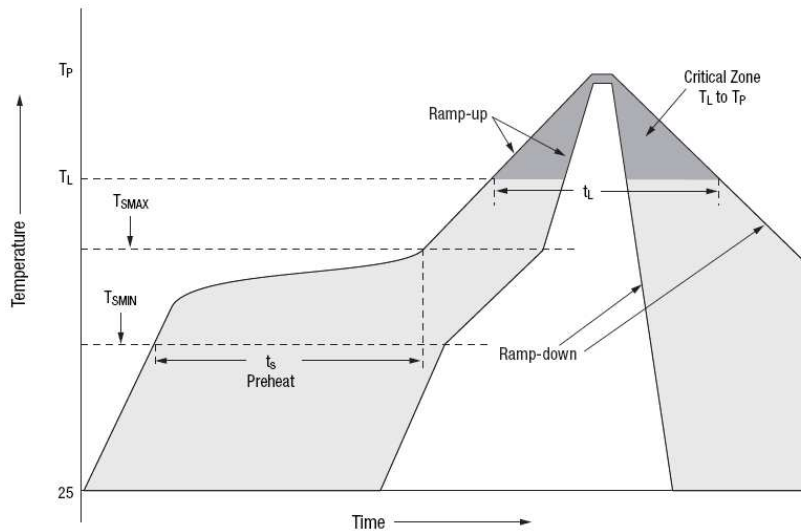

If the accelerometer is to be subjected to high amplitude shocks during operation then it is also recommended to apply a thin layer of epoxy underneath the accelerometer after solder attachment. A low viscosity cyanoacrylate with a room temperature cure such as Loctite 4501 is recommended.

For maximum mounting rigidity, encapsulating the sensor with potting compound after the reflow process can be critical. Encapsulant, such as Stycast 2651-40 by Emerson & Cuming, is recommended.

Note that the gold-plated pads of the 3038 are also suitable for conductive epoxy attachment should solder reflow not be a convenient mounting solution.

### EXCITATION

The model 3038 is a piezo-resistive (PR) accelerometer that requires a clean and stable, low noise dc power supply or battery supply. The output sensitivity is ratiometric to excitation voltage so any ripple in the excitation will affect the sensitivity accordingly. The accelerometers are calibrated at 5Vdc excitation but can also be used with an excitation voltage from 2-10Vdc. However, it is recommended that you contact the Vibration Application Support prior to using a non-standard excitation voltage as it will affect the calibrated sensitivity, ZMO, and TC errors.

The sensor element used in the model 3038 accelerometer is a MEMS device with some operating characteristics that are different than a purely resistive Wheatstone bridge. There is a parasitic P-N junction in series with the bridge.

**For this reason the positive and negative excitation voltages should not be reversed.**

### SIGNAL CONDITIONING

The model 3038 accelerometer incorporates a PR Wheatstone-bridge sensing element with true differential signal outputs. The positive and negative outputs of the unit should be connected to differential input amplifiers with an input impedance of at least 1 Meg Ohm referred to ground. The amplifier should also have good common mode rejection and a suitable bandwidth for the application.

In situations where the signal-conditioning amplifier has a single-ended input, one of the outputs should be left unconnected (with the sensitivity reduced to ½ the specified value). The unused output should not be tied to ground or any low impedance. Grounding the unused output will result in a short circuit across half of the bridge. This will have an adverse affect on the operation of the sensor. The increased current flowing through one half of the bridge will cause the bridge to be unbalanced with unequal heating and unpredictable results from the other half of the bridge.

## TEMPERATURE COMPENSATION

The model 3038 accelerometer is a mV output piezo-resistive accelerometer that is sensitive to temperature variations. Should the accelerometer be used over a wide temperature range it is recommended to incorporate a temperature compensating circuit to negate any zero output or sensitivity shifts over temperature. There are numerous methods for compensating a PR accelerometer and a typical temperature compensation circuit is detailed below. Please refer to Technical Note TN-009 for additional information or contact the local application support.

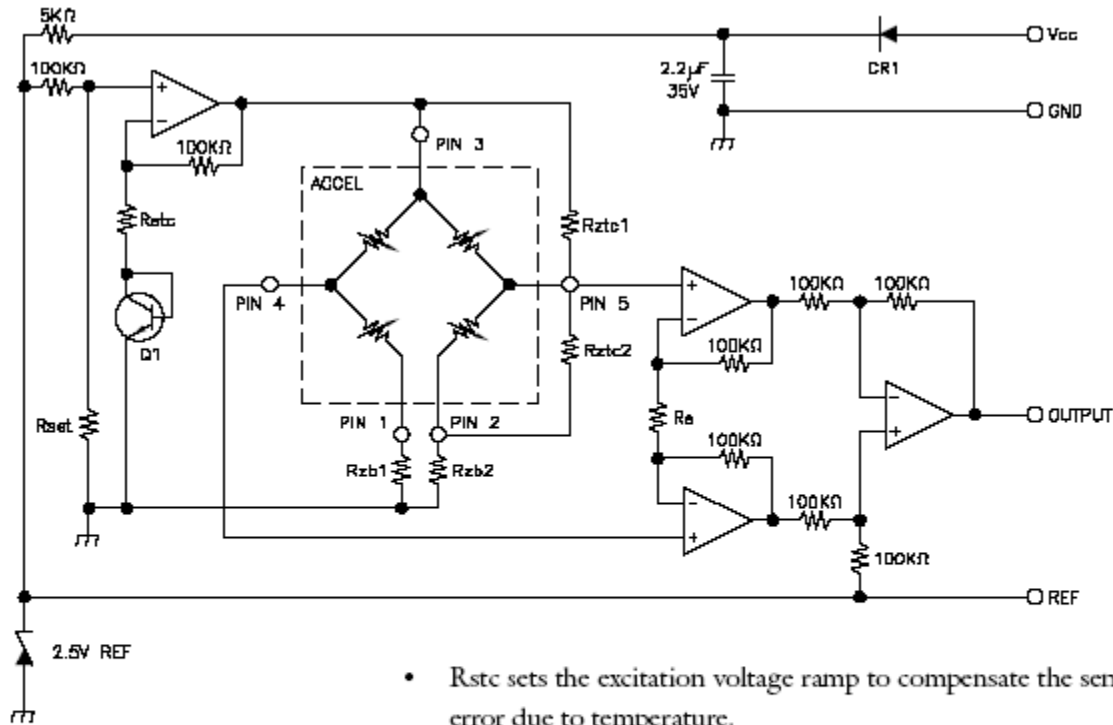

- Rstc sets the excitation voltage ramp to compensate the sensitivity error due to temperature.
- Rset sets the excitation voltage to 5V at 25°C.
- Rzb1, Rzb2 and Rztc1 and Rztc2 calibrate the zero offset and compensate the offset error due to temperature.
- Ra calibrates the output span.
- Vcc must be >8 VDC.

## NORTH AMERICA

Measurement Specialties, Inc.,  
a TE Connectivity Company  
1000 Lucas Way  
Hampton, VA 23666  
United States  
Tel: +1 757 766 1500  
Email: [customercare.hmpt@te.com](mailto:customercare.hmpt@te.com)

Measurement Specialties, Inc.,  
a TE Connectivity Company  
Vibration Sensors Design Center  
32 Journey, Suite 150  
Aliso Viejo, CA 92656, USA  
Tel: +1 949 716 7324

### [te.com/sensorsolutions](http://te.com/sensorsolutions)

Measurement Specialties, Inc., a TE Connectivity company.

Measurement Specialties (MEAS), American Sensor Technologies (AST), TE Connectivity, TE Connectivity (logo) and EVERY CONNECTION COUNTS are trademarks. All other logos, products and/or company names referred to herein might be trademarks of their respective owners.

The information given herein, including drawings, illustrations and schematics which are intended for illustration purposes only, is believed to be reliable. However, TE Connectivity makes no warranties as to its accuracy or completeness and disclaims any liability in connection with its use. TE Connectivity's obligations shall only be as set forth in TE Connectivity's Standard Terms and Conditions of Sale for this product and in no case will TE Connectivity be liable for any incidental, indirect or consequential damages arising out of the sale, resale, use or misuse of the product. Users of TE Connectivity products should make their own evaluation to determine the suitability of each such product for the specific application.

© 2016 TE Connectivity Ltd. family of companies All Rights Reserved.

## EUROPE

MEAS Deutschland GmbH  
a TE Connectivity Company  
Impasse Jeanne BENOZZI  
CS 83 163, 31027 Toulouse Cedex 3, France  
Tel: +33 (0) 582 08 22 00  
Email: [customercare.tfse@te.com](mailto:customercare.tfse@te.com)

## ASIA

Measurement Specialties China Ltd.,  
a TE Connectivity Company  
No. 26, Langshan Road  
High-tech Park (North)  
Nanshan District, Shenzhen 518057  
China  
Phone: +86-755-33305088  
Email: [customercare.shzn@te.com](mailto:customercare.shzn@te.com)