

Installation and Operating Manual SWITCHBOARD INTEGRA DISPLAY 0240

INTEGRA DISPLAY 0240

Digital Metering of Volts
and Frequency



Contents	Page
1 Introduction	1
2 Display Screens	2 – 4
2.1 Screen 1 – System Screen	2
2.2 Screen 2 – Line to Neutral Voltages	2
2.3 Screen 3 – Line to Line Voltages	2
2.4 Error Messages	3
3 Programming	3
3.1 Password Protection	4 – 6
3.2 Set-Up Screens	6
3.2.1 Potential Transformer Ratio	6
3.2.2 Potential Multiplier Edit	6
3.2.3 Potential Transformer Secondary Value	7
3.2.4 Potential Transformer Secondary Decimal Point Edit	7
3.2.5 Potential Transformer Secondary Digit Edit	8
3.2.6 Potential Transformer Secondary Value Confirmation	8
4 Specification	9
Inputs	9
Auxiliary	9
Measuring Ranges	9
Accuracy	9
EMC Standards	9
Safety	9
Insulation	9
Environmental	9
Enclosure	9
5 Installation	10 – 12
5.1 Introduction	10
5.2 EMC Installation Requirements	10
5.3 Case Dimension and Panel Cut-Out	11
5.4 Wiring	12
5.5 Fusing	12
6 Maintenance	12

1 Introduction

The Crompton Switchboard INTEGRA 0240 is a panel mounted self contained display device. This system will display up to 8 electrical parameters, in conjunction with an INTEGRA 15xx series transducer.

The INTEGRA 0240 front panel has two push buttons, referred to as “keys”. The two keys allow the user to select the required display and to configure the INTEGRA 0240.

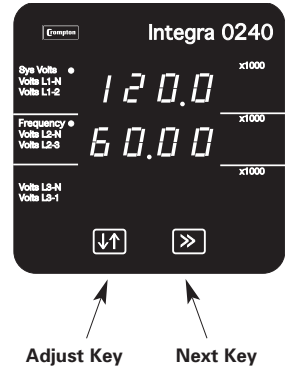

Measured Quantity	Units of measurement
System Voltage	Volts
System Frequency	Hz
Voltage L-N (4 wire only)	Volts
Voltage L-L (calculated in 4 wire)	Volts

Important safety information is contained in the installation section. Installers must familiarise themselves with this section before installation.

2 Display Screens

Use the >> (Next) key to scroll from one screen to the next in sequence. The sequence depends on the supply type (3 phase 3 wire or 3 phase 4 wire) as screen 2 is not shown on 3 wire systems.

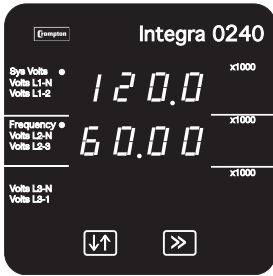

2.1 Screen 1 – System Screen

The system screen is the default display. It appears when the unit is energised.

System Average Voltage (Volts)
 {Line to Line for 3 wire systems,
 Line to Neutral for 4 wire systems}

System Frequency (Hz)

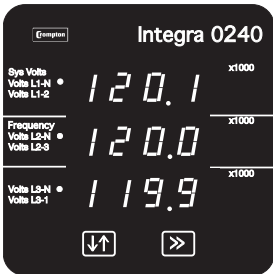

2.2 Screen 2 – Line to Neutral Voltages

Three phase, four wire systems only.

Voltage Line 1 to Neutral (Volts)

Voltage Line 2 to Neutral (Volts)

Voltage Line 3 to Neutral (Volts)



2.3 Screen 3 – Line to Line Voltages

Voltage Line 1 to Line 2 (Volts)

Voltage Line 2 to Line 3 (Volts)

Voltage Line 3 to Line 1 (Volts)

2.4 Error Messages

The display screen repeatedly requests new values from the measurement processor. If there is a problem obtaining these values the display will continue to retry but will alert the user by displaying the message Err1. This message may be seen briefly during conditions of extreme electromagnetic interference with the normal display returning once the interference has ceased. If the Err1 message persists a 10 second interruption to the auxiliary supply may restore normal operation.

3 Programming

The following sections comprise step by step procedures for configuring the associated transducer for individual user requirements.

To access the set-up screens press and hold the “↓↑ Adjust” and “>> Next” keys simultaneously for 5 seconds. This will take the user into the password protection entry stage. (See Section 3.1 Password Protection). To return to the display screens at any time during these procedures, press the “↓↑ Adjust” and “>> Next” keys simultaneously for 5 seconds.

3.1 Password Protection

Password protection can be enabled to prevent unauthorised access to set-up screens. By default password protection is not enabled.

Password protection is enabled by selecting a four digit number other than 0000. Setting a password of 0000 disables the password protection.

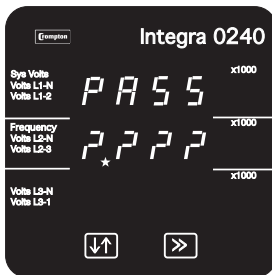

Enter Password, prompt for first digit.

(* Denotes that decimal point will be flashing).

Press the “↓↑ Adjust” key to scroll the value of the first digit from 0 through to 9, the value will wrap from 9 round to 0.

Press the “>> Next” key to advance to the next digit.

In the special case where the Password is “0000” pressing the “>> Next” key when prompted for the first digit will advance to the “Password Confirmed” screen.

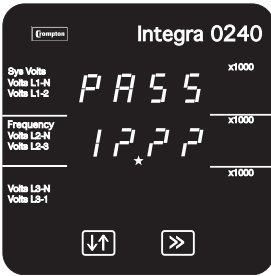

Enter Password, first digit entered, prompt for second digit.
 (* Denotes that decimal point will be flashing).

Press the "↑ Adjust" key to scroll the value of the second digit from 0 through to 9, the value will wrap from 9 round to 0.

Press the ">> Next" key to advance to the next digit.



Enter Password, second digit entered, prompt for third digit.
 (* Denotes that decimal point will be flashing).

Use the "↑ Adjust" key to scroll the value of the third digit from 0 through to 9, the value will wrap from 9 round to 0.

Press the ">> Next" key to advance to the next digit.

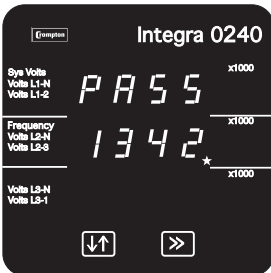

Enter Password, third digit entered, prompt for fourth digit.
 (*decimal point indicates that this will be flashing.)

Use the "↑ Adjust" key to scroll the value of the fourth digit from 0 through to 9, the value will wrap from 9 round to 0.

Press the ">> Next" key to advance to verification of the password.



Enter Password, fourth digit entered, awaiting verification of the password.

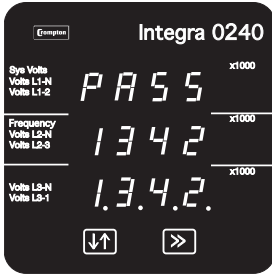

Password Confirmed

Pressing “↓↑ Adjust” key will advance to the “New/Change Password” entry stage.

Pressing the “>> Next” key will advance to the Potential Transformer Primary Value Set-up Screen.

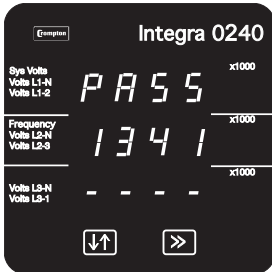

Password Incorrect

The unit has not accepted the password entered.

Pressing the “↓↑ Adjust” key will return to the “Enter Password” stage.

Pressing the “>> Next” key exits the set-up menus and returns operation to the normal display mode.

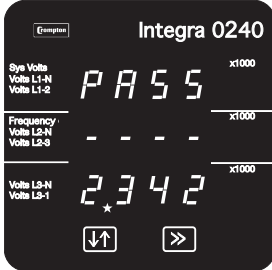

New/Change Password.

(* decimal point indicates that this will be flashing.)

Pressing the “↓↑ Adjust” key will scroll the value of the first digit from 0 through to 9, the value will wrap from 9 round to 0.

Pressing the “>> Next” key advances the operation to the next digit and sets the first digit, in this case to “2”.

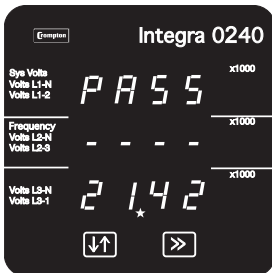

New/Change Password, first digit entered, prompting for second digit. (*decimal point indicates that this will be flashing)

Pressing the “↓↑ Adjust” key will scroll the value of the second digit from 0 through to 9, the value will wrap from 9 round to 0.

The procedure for second, third and fourth digits follows the same principals.

Pressing the “>> Next” key advances to the new password confirmed screen.

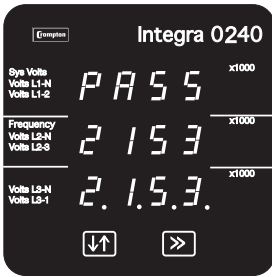

New Password Confirmed.

Pressing “↓↑ Adjust” key will return to the “New/Change Password”.

Pressing the “>> Next” key will advance to the Potential Transformer Primary Value Set-Up Screen.

3.2. Set-up Screens

3.2.1 Potential Transformer Ratio

This defines the nominal full scale voltage which will be displayed as the L1-N, L2-N and L3-N for a four wire system or as L1-2, L2-3 and L3-1 in a three wire system. This screen enables the user to display the line to neutral and line to line voltages inclusive of any transformer ratios. The values displayed represent the voltage in kilovolts (note the x1000 annunciator). For example on a 2.2kV system with 110v PT secondary, set 2.200 at this screen.

If there is no PT in the system, leave this value unchanged and skip this set up step. If the PT primary and secondary values are changed and it is desired to revert to a set up with no PT, then set both PT primary and secondary values to the nominal maximum voltage for the associated transducer.

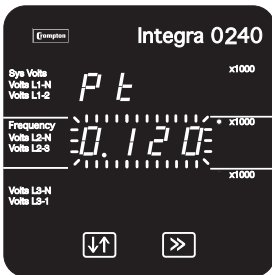

3.2.2 Potential Transformer Primary Value

Pressing the “>> Next” key accepts the present value and advances to the “Potential Transformer Secondary Value” menu. (See Section Potential Transformer Secondary Value).

Pressing the “↓↑ Adjust” key will enter the “PT Primary Multiplier Edit” Mode.

Initially all the digits of the present value will be flashing and the decimal point position will be illuminated. This is to indicate that initially the “multiplier” must be selected, pressing the “↓↑ Adjust” key will move the decimal point position to the right until it reaches ###.# after which it will return to #.###

Pressing the “>> Next” key will accept the present multiplier (decimal point position), stop the digits flashing and advances to the “PT Primary Digit Edit” mode

PT Primary Digit Edit

Pressing the “↓↑ Adjust” key will scroll the value of the most significant digit from 0 through to 9 unless it is attempted to set the PT Primary to over 400 kV in which case the digit range will be restricted.

Pressing the “>> Next” key accepts the present value at the cursor position and advances the cursor to the next less significant digit.

(* Denotes that decimal point will be flashing).

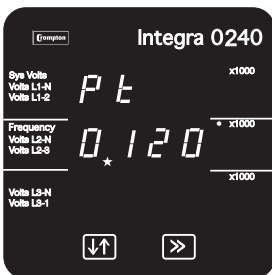

Note: the flashing decimal point indicates the cursor position. A steady decimal point will be present to identify the scaling of the number until the cursor position coincides with the steady decimal point position. At this stage the decimal point will flash.

When the least significant digit has been set pressing the ">> Next" key will advance to the "PT Primary Value Confirmation" stage.

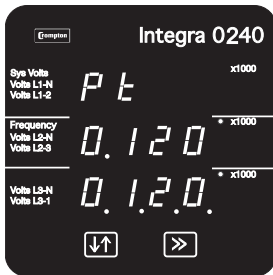

PT Primary Value Confirmation

This screen will only appear following an edit of the PT Primary Value.

If the scaling is not correct, pressing "↑ Adjust" will return to the "Potential Transformer Ratio Edit" stage with the digits flashing indicating that the multiplier (decimal point position) should be selected.

Pressing the ">> Next" key sets the displayed value and will advance to the "Potential Transformer Secondary Value" menu.

3.2.3 Potential Transformer Secondary Value

The nominal full scale secondary voltage will be displayed as the L1-N, L2-N and L3-N for a four wire system or as L1-2, L2-3 and L3-1 in a three wire system. This screen enables the user to define the PT secondary value which corresponds to the primary value set previously. The secondary voltage shown is in volts. Following the previous example, on a 2.2kV system with 110V PT secondary, set 110 at this screen. If there is no PT in the system, leave this value unchanged and skip this step.

3.2.4 Potential Transformer Secondary Decimal Point Edit

Pressing the ">> Next" key accepts the present value and returns to the display mode.

Pressing "↑ Adjust" will enter the "PT Secondary Value" Mode depending on the system build voltage. See note below.

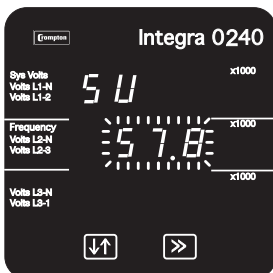

Initially all the digits of the current value will be flashing and the decimal point position illuminated. This is to indicate that initially the "multiplier" must be selected, pressing "↑ Adjust" will move the decimal point position to the right.

Note that the decimal point edit will only appear when the Integra 0240 is factory configured for connection to voltages in the range 57.7 to 139V.

Pressing "↑ Adjust" will move the decimal point to allow voltages less than 100V to be entered, e.g. 57.7V L-N.



3.2.5 Potential Transformer Secondary Digit Edit

Pressing “↓↑ Adjust” will scroll the value of the most significant digit within the range indicated on the rating label.

Pressing the “>> Next” key accepts the present value at the cursor position and advances the cursor to the next less significant digit.

Note: the flashing decimal point indicates the cursor position. A steady decimal point will be present to identify the scaling of the number until the cursor position coincides with the steady decimal point position. At this stage the decimal point will flash.

When the least significant digit has been set pressing the “>> Next” key will advance to the “Potential Transformer Secondary Value Confirmation” stage.



3.2.6 Potential Transformer Secondary Value Confirmation

This screen will only appear following an edit of the Potential Transformer Secondary Value.

If the value is not correct, pressing “↓↑ Adjust” will return to the “Potential Transformer Secondary Value Edit” stage.

Pressing the “>> Next” will return to the display mode.

The secondary value may only be set to values within the range defined by the factory voltage build option. These nominal RMS input voltages are shown in the Specification section.

4 Specification

Input

RS485 Dedicated to Crompton Integra Transducers

Auxiliary

Standard nominal supply voltages	100 to 250V a.c. nominal $\pm 15\%$ (85V AC absolute minimum to 287V AC absolute maximum) or 100 to 250V d.c.. nominal -15% , $+25\%$ (85V DC absolute minimum to 312V DC absolute maximum)
a.c. supply frequency range	45 to 66 Hz
a.c. supply burden	4VA approx.
Optional auxiliary d.c.supply	12 to 48V d.c. -15% $+ 25\%$ (10.2V DC absolute minimum to 60V DC absolute maximum)
d.c. supply burden	4VA approx.

EMC Standards

EMC Immunity	EN61326 for Industrial Locations to performance criterion A
EMC Emissions	EN61326 to Class A - Industrial

Safety

IEC1010-1 (BSEN 61010-1) Permanently connected use, Normal Condition Installation category III, pollution degree 2, Basic Insulation 300V RMS maximum. All terminals are for use only with equipment that has no live parts WHICH ARE ACCESSIBLE and the insulation for external circuits is to be suitable for SINGLE FAULT CONDITIONS.

Insulation

Dielectric voltage withstand test	3.25kV RMS 50Hz for 1 minute between all electrical circuits
-----------------------------------	--

Environmental

Operating temperature	-10 to +60°C
Storage temperature	-20 to +85°C
Relative humidity	0 .. 95% non condensing
Shock	30g in 3 planes
Vibration	10-150 Hz, 1g/0.15mm amplitude
Enclosure integrity (front face only)	IP54

Enclosure

Style	ANSI C39.1
Material	Polycarbonate front and base, steel case
Terminals	Screw clamp style

5 Installation and Maintenance

5.1 Introduction

The Integra 0240 Display may be mounted in a panel of any thickness up to a maximum of 0.4"/10mm. Mounting is by four 1/4 - 28 UNF corner studs and nuts. Consideration should be given to the space required behind the instrument to allow for bends in the connection cables.

As the enclosure conforms to IP54 it is protected from water spray. Additional protection to the panel may be obtained by the use of an optional panel gasket. The terminals at the rear of the product must be protected.

The Integra 0240 Display should be mounted in a reasonably stable ambient temperature within the range -10 to +60°C. Vibration should be kept to a minimum and the product should not be mounted where it will be subjected to excessive direct sunlight.

These units are intended for indoor use only at an altitude of less than 2000m.

Warning

- During normal operation, voltages hazardous to life may be present at some of the terminals of this unit. Installation and servicing should be performed only by qualified, properly trained personnel abiding by local regulations. Ensure all supplies are de-energised before attempting connection or other procedures.
- It is recommended adjustments be made with the supplies de-energised, but if this is not possible, then extreme caution should be exercised.
- Terminals should not be user accessible after installation and external installation provisions must be sufficient to prevent hazards under fault conditions.
- This unit is not intended to function as part of a system providing the sole means of fault protection - good engineering practice dictates that any critical function be protected by at least two independent and diverse means.

5.2 Electromagnetic Compatibility

This unit has been designed to provide protection against EM (electro-magnetic) interference in line with requirements of EU and other regulations. Precautions necessary to provide proper operation of this and adjacent equipment will be installation dependent and so the following can only be general guidance:-

- Avoid routing wiring to this unit alongside cables and products that are, or could be, a source of interference.
- The auxiliary supply to the unit should not be subject to excessive interference. In some cases, a supply line filter may be required.
- To protect the product against incorrect operation or permanent damage, surge transients must be controlled. It is good EMC practice to suppress differential surges to 2kV or less at the source. The unit has been designed to automatically recover from typical transients, however in extreme circumstances it may be necessary to temporarily disconnect the auxiliary supply for a period of greater than 10 seconds to restore correct operation.
- Screened communication and small signal leads are recommended and may be required. These and other connecting leads may require the fitting of RF suppression components, such as ferrite absorbers, line filters etc., if RF fields cause problems.
- It is good practice to install sensitive electronic instruments that are performing critical functions in EMC enclosures that protect against electrical interference causing a disturbance in function.

5.3 Case Dimension and Panel Cut-Out

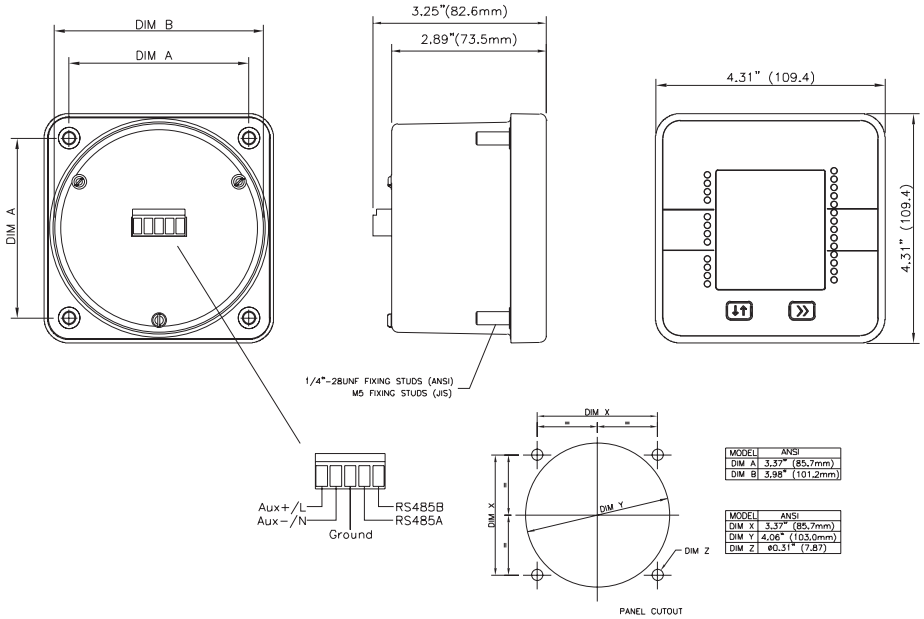

5.4 Wiring

The connections between the display and transducer are made with two-part detachable screw clamp style connectors. The recommended cable between the display and transducer is two core screened cable. Preferably select a cable specifically recommended for RS485 use (for example Belden 9860, 8761) although for shorter distances of a few metres most two core screened cables will often be satisfactory. The display to transducer communication uses RS485 and therefore cable length (transmission distance) can be up to 1200 metres in good conditions. Electrical interference may reduce the maximum cable length possible for reliable operation.

5.5 Fusing and connections

This unit must be fitted with external fuses in auxiliary supply lines. Auxiliary supply lines must be fused with a slow blow fuse rated 1A maximum. Choose fuses of a type and with a breaking capacity appropriate to the supply and in accordance with local regulations.

A switch or circuit breaker allowing isolation of supplies to the unit must be provided.

Screw torque

Detachable terminal connector screws should be tightened to 0.9Nm or 0.7 ft/lbf only.

6 Maintenance

In normal use, little maintenance is needed. As appropriate for service conditions, isolate electrical power, inspect the unit and remove any dust or other foreign material present. Periodically check all connections for freedom from corrosion and screw tightness, particularly if vibration is present.

The front of the case should be wiped with a dry cloth only. Use minimal pressure, especially over the viewing window area. If necessary wipe the rear case with a dry cloth. If a cleaning agent is necessary, isopropyl alcohol is the only recommended agent and should be used sparingly. Water should not be used. If the rear case exterior or terminals should accidentally be contaminated with water, the unit must be thoroughly dried before further service. Should it be suspected that water might have entered the unit, factory inspection and refurbishment is recommended.

In the unlikely event of a repair being necessary, it is recommended that the unit be returned to the factory or nearest Crompton service centre.

Notes

The Information contained in these installation instructions is for use only by installers trained to make electrical power installations and is intended to describe the correct method of installation for this product. However, Tyco Electronics has no control over the field conditions which influence product installation.

It is the user's responsibility to determine the suitability of the installation method in the user's field conditions. Tyco Electronics' only obligations are those in Tyco Electronics' standard Conditions of Sale for this product and in no case will Tyco Electronics be liable for any other incidental, indirect or consequential damages arising from the use or misuse of the products. Crompton is a trade mark.



Tyco Electronics UK Limited
Crompton Instruments

Freebournes Road, Witham, Essex, CM8 3AH, UK
Tel: +44 1376 509 509 Fax: +44 1376 509 511

<http://energy.tycoelectronics.com>