

1 はじめに

1.1 目的

本試験は、1.0mm ピッチ I/O コネクタの、製品規格 108-78646 に規定された性能必要条件に合致しているか確認するために行われた。

1.2 適用範囲

本報告書は、1.0mm ピッチ I/O コネクタの、電氣的、機械的及び環境的性能必要条件について行なった試験内容を記述している。

本製品確認試験は、2009年3月25日から2009年5月15日までに行われた。

1.3 結論

1.0mm ピッチ I/O コネクタは、該当の製品規格 108-78646 の性能必要条件に合致していた。

1.4 試料

試料は現行の生産システムから無作為抽出法により取り出された。以下の試料が試験に使用された。

1. Introduction

1.1 Testing was performed on the 1.0 mm Pitch I/O Connector to determine if it meets the requirements of TE Specification, 108-78646.

1.2 Scope

This report covers the electrical, mechanical and environmental performance requirements of the 1.0 mm Pitch I/O Connector

The qualification testing was performed between 25-MAR-2009 and 15-MAY-2009.

1.3 Conclusion

1.0 mm Pitch I/O Connector meets the electrical, mechanical and environmental performance requirements of Product Specification, 108-78646.

1.4 Test Samples

Samples were taken randomly from current production. The following samples were used:

型番 Product Part No.	品名
2040800-□	1mm I/O CONN External REC R/A 50p
2040805-□	1mm I/O CONN Internal REC R/A 50p
2040809-□	1mm I/O CONN Internal REC V 50p
2040812-□	1mm I/O CONN Internal-Internal Cable ASSY 50p
2040954-□	1mm I/O CONN External-Internal Cable ASSY 50p
2320557-□	1mm WIRE TO BOARD INTERNAL CABLE ASSY 50p
2323692-□	1mm WIRE TO BOARD INTERNAL CABLE ASSY 50p

Fig. 1

2. 試験内容

2. Test Contents

項番	試験項目	必要条件	判定
No.	Test Items	Requirements	Judgement
2.1	製品の確認	目視により、コネクタの機能上支障をきたす損傷なきこと。	合格
	Examination of Product	Visual Inspection No physical damage	Acceptable

電 気 的 性 能 Electrical Requirements

2.2	総合抵抗 (ローレベル)	初期 ; 40 mΩ 以下 試験後 ; $\angle R=20$ mΩ 以下 Fig.3	合格
	Termination Resistance (Low Level)	Initial ; 40 mΩ Max. Final ; $\angle R=20$ Max. Obtain resistance value by dividing the measured reading into two. Fig.3	Acceptable

2.3	絶縁抵抗	初期 ; 100MΩ 以上 試験後 ; 50MΩ 以上	合格
	Insulation Resistance	Initial ; 100MΩ Min. Final ; 50MΩ Min.	Acceptable

2.4	耐電圧	初期、試験後共 0.5 kV AC, (50 Hz), 1 分間、異常なし リーク電流 : 0.5mA 以下	合格
	Dielectric withstanding Voltage	Initial/Final ; 0.5kV AC, (50 Hz), 1 minute No abnormality allowed. Current leakage : 0.5mA Max.	Acceptable

2.5	温度上昇	定格電流を通电して、温度上昇は 30°C以下	合格
	Temperature Rising	30°C Max. under loaded rating current.	Acceptable

機 械 的 性 能 Mechanical Requirements

項番	試験項目	必要条件	判定
No.	Test Items	Requirements	Judgement
2.6	コネクタ挿入力	55N 以下	合格
	Connector Mating Force	55N Max.	Acceptable

Fig. 2 (続く) (to be continued)

項番	試験項目	必要条件	判定
No.	Test Items	Requirements	Judgement
2.7	コネクタ抜去力 (ロック無)	3N 以上 (1pos=0.06N 以上) 55N 以下	合格
	Connector Unmating Force (With out Lock)	3N MIN (1pos=0.06N MIN) 55N Max	Acceptable
2.8	耐久性 (繰り返し挿抜)	コネクタを50回挿抜する。 総合抵抗 : $\Delta R=20m\Omega$ 以下 (終期)	合格
	Durability (Repeated Mating/ Un-mating)	Mate and un-mate Connector for 50 cycles. Termination Resistance: $\Delta R=20m\Omega$ Max (Final)	Acceptable
2.9	ロック強度	ロックが外れる時の力を測定する。 操作速度 : 10mm/分 30N 以上	合格
	Lock Strength	Measure the force required to come off Lock Operation speed: 10mm/min. 30N Min	Acceptable
2.10	圧着端子保持力	電線付きの圧着端子をハウジングに挿入し、 各リードを引き抜く。 操作速度 : 25mm/分 7.0N 以上	合格
	Crimp Contact Retention Force	The Crimp Terminal with the wire shall be inserted into The Housing and each lead shall be Operation speed: 25mm/min. 7.0N Min	Acceptable
2.11	圧着部引張強度 (AWG #30)	圧着した電線を引張試験機にて、軸方向に引張測定する。 操作速度 : 50mm/分 試験サンプルの被覆部は圧着しないで測定すること。 9.8N 以上	合格
	Crimp Tensile Strength (AWG #30)	Apply an axial pull off load to crimped Wire of contact secured on the tester, Operation Speed : 50mm/min Samples don't crimp insulation. 9.8N Min	Acceptable

Fig. 2 (続く) (to be continued)

項番	試験項目	必要条件	判定
No.	Test Items	Requirements	Judgement
2.12	振動 (低周波)	10~55~10 Hz/ 1 分間、 全振幅 1.52mm、XYZ 各方向 2 時間 不連続導通は 1 μ sec をこえないこと。 $\Delta R=20m\Omega$ 以下 (終期)	合格
	Vibration (Low Frequency)	10~55~10 Hz/1 minutes, Amplitude :1.52mm, X, Y & Z Axes : 2 hours each No electrical discontinuity greater than 1 μ sec shall occur. $\Delta R=20m\Omega$ Max.(Final)	Acceptable
2.13	衝撃	不連続導通は 1 μ sec をこえないこと。 490 m/s ² (50 G), 半波正弦波 X,Y,Z 軸正逆方向に各 3 回、合計 18 回 $\Delta R=20m\Omega$ 以下 (終期)	合格
	Physical Shock	No electrical discontinuity greater than 1 μ sec allowed. 490 m/s ² (50 G), Halfsine Wave. X,Y,Z \pm directions each 3 drops, Total 18 drops $\Delta R=20m\Omega$ Max.(Final)	Acceptable
2.14	はんだぬれ性	はんだ温度: 245 \pm 5 $^{\circ}$ C (前処理: PTC105 $^{\circ}$ C、100%R.H.、4 時間) 平衡法にてゼロクロス時間 3 秒以内。	合格
	Solderability	Solder Temperature: 245 \pm 5 $^{\circ}$ C Zero cross time by wetting balance method: 3 sec Max.	Acceptable
2.15	ケーブル屈曲	2平面の両方に200サイクルを行う。 屈曲角度: 90 $^{\circ}$ Fig. 4 参照	合格
	Cable Flex	200 cycle in each of 2 planes. 90 $^{\circ}$ Flex Fig. 4	Acceptable

Fig. 2 (続く) (to be continued)

項番	試験項目	必要条件	判定
No.	Test Items	Requirements	Judgement
2.16	はんだ耐熱性	<u>リフローソルダリング</u> 温度プロファイルは、108-78524 の Fig. 5 参照 温度は、本体部表面上とする。 <u>手はんだ</u> 温度: 350±10 °C 時間: 3 (+1/-0) 秒 但し、コンタクトはんだ付け部にこて先等による力が加わらないように試験する。	合格
	Resistance to soldering heat	<u>Reflow soldering</u> Temperature profiles: as shown in Fig. 5 The specified temperature is measured at the surface of P.C.B. <u>Manual soldering</u> Temperature: 350±10 °C for 3 (+1/-0) sec. To be no damage by the top of iron at soldering tines.	Acceptable

環境的性能 Environmental Requirements

2.17	耐寒性	コネクタ嵌合状態で下記状況に放置。 -40±3°C、96時間 総合抵抗: $\Delta R=20\text{m}\Omega$ 以下 (終期) 外観に異常なきこと。 (ケーブル抵抗は含まない)	合格
	Cold	Mated connector with cable, -40±3°C、96hr. Termination Resistance: $\Delta R=20\text{m}\Omega$ Max(Final) No physical damage allowed. (Not include resistance of Cable)	Acceptable
2.18	耐熱性	コネクタ嵌合状態で下記状況に放置。 85±2°C、96時間 総合抵抗: $\Delta R=20\text{m}\Omega$ 以下 (終期) 外観に異常なきこと。 (ケーブル抵抗は含まない)	合格
	Dry Heat	Mated connector with cable, 85±2°C、96hr. Termination Resistance: $\Delta R=20\text{m}\Omega$ Max(Final) No physical damage allowed. (Not include resistance of Cable)	Acceptable

Fig. 2 (続く) (to be continued)

項番	試験項目	必要条件	判定
No.	Test Items	Requirements	Judgement
2.19	耐湿性 (定常状態)	コネクタ嵌合状態で下記状況に放置。 40±2℃、90～95%R.H、96 時間 総合抵抗: $\Delta R=20\text{m}\Omega$ 以下 (終期) 絶縁抵抗 50 M Ω 以上 (終期) 外観に異常なきこと (ケーブル抵抗は含まない)	合格
	Damp Heat (Steady State)	Mated connector with cable, 40±2℃、90～95%R. H.、96hr. Termination Resistance: $\Delta R=20\text{m}\Omega$ Max(Final) Insulation resistance: 50M Ω Min(Final) Dielectric Strength: No Abnormality No physical damage allowed) (Not include resistance of Cable)	Acceptable
2.20	温度サイクリング	コネクタ嵌合状態で下記状況に放置 -55±3℃/30分、常温10～15分、85±2℃/30分、 常温10～15分 これを1サイクルとし、5サイクル実施 総合抵抗: $\Delta R=20\text{m}\Omega$ 以下 (終期) 外観に異常なきこと。 (ケーブル抵抗は含まない)	合格
	Temperature-Humidity Cycling	Mated connector with cable, -55±3℃ / 30 min, Room Temp:10～15min. 85±2℃ / 30 min. Room Temp:10～15min. Making this a cycle, repeat 5 cycles Termination Resistance:150m Ω Max(Final) (Not include resistance of Cable)	Acceptable
2.21	塩水噴霧	コネクタ嵌合状態にて温度 35±2℃, 5±1% の塩水を8時間 噴霧、16 時間休止、これを3 サイクル行うこと。試験後塩水を 水洗いし、常温常湿中に1 時間放置した後測定する 総合抵抗: $\Delta R=20\text{m}\Omega$ 以下 (終期) (ケーブル抵抗は含まない)	合格
	Salt Spray	Mated connector with cable 35±2℃, 5±1% salt concentration for 8 hours, pause for 16 hours, at 3 cycles. After test, rinse the samples with water and recondition to room temperature for 1 hour. 150 m Ω Max. (Final) (Not include resistance of ケーブル)	Acceptable

Fig. 2 (続く) (to be continued)

項番	試験項目	必要条件	判定
No.	Test Items	Requirements	Judgement
2.22	工業ガス(SO ₂)	コネクタ嵌合状態 SO ₂ ガス 10ppm, 95% R.H. 25°C,に 24 時間放置し常温常湿中に 1 時間放置した後測定する 総合抵抗: $\Delta R=20m\Omega$ 以下 (終期) (ケーブル抵抗は含まない)	合格
	Industrial Gas(SO ₂)	Mated connector SO ₂ Gas : 10ppm, 95% R.H. 25°C, 24hours and recondition to room temperature for 1 hour 150 m Ω Max. (Final) (Not include resistance of ケーブル)	Acceptable
2.23	耐湿性 (温湿度サイクリング)	嵌合したコネクタを 25~60°C, 95%R. H. へ 10サイクル (24 H/サイクル)放置後、常温中に1時間放置し測定する。 総合抵抗: $\Delta R=20m\Omega$ 以下 (終期) (ケーブル抵抗は含まない)	合格
	Industrial Gas(SO ₂)	Mated connector shall be stored at the atmosphere as 25~65°C, 90~95%R. H. for 10 cycles (24 H/cycle). Then in shall be subjected to standard atmospheric condition for 1hr, after which measurement shall be made. 150 m Ω Max. (Final) (Not include resistance of ケーブル)	Acceptable

Fig. 2 (終り) Fig. 2 (End)

3. 認定試験の試験順序

3. Product Qualification Test Sequence

試験項目	Test Items	試験グループ/Test Group																			
		1	2	3	4	5	6	7	8	9	10	11	12	13	14	15	16	17	18	19	20
		試験順序/Test Sequence (a)																			
製品の確認検査	Examination of Product	1, 4	1, 3	1	1	1, 5	1	1	1	1, 5	1, 5	1	1	1	1, 5	1, 5	1, 9	1, 5	1, 5	1, 5	1, 5
総合抵抗 (ローレベル)	Termination Resistance (Low Level)					2, 4				2, 4	2, 4				2, 4	2, 4	2, 8	2, 4	2, 4	2, 4	2, 4
耐電圧	Dielectric Withstanding Voltage	2															3, 6				
絶縁抵抗	Insulation Resistance	3															4, 7				
温度上昇	Temperature Rising		2																		
コネクタ挿入力	Cable Mating Force			2																	
コネクタ抜去力 (ロック無し)	Cable Um-Mating Force (Without Lock)				2																
耐久性	Durability (Repeated Mate/Unmating)					3															
ロック強度	Lock Strength						2														
圧着端子保持力	Crimp Contact Retention Force							2													
圧着部引張強度	Crimp Tensile Strength								2												
振動 (低周波)	Vibration (Low Frequency)									3											
衝撃	Physical Shock										3										
はんだぬれ性	Solderability											2									
ケーブル屈曲	Cable Flex												2								
はんだ耐熱性	Resistance Reflow Heat													2							
耐寒性	Cold														3						
耐熱性	Dry Heat															3					
耐湿性 (定常状態)	Damp Heat (Steady State)																5				
温度サイクル	Temperature Cycle																	3			
塩水噴霧	Salt Spray																		3		
工業ガス (SO2)	Industrial Gas (SO2)																			3	
耐湿性 (温湿度サイクル)	Composite temperature Humidity Cyclic Test																				3

Fig 2

(a) 欄内の数字は試験の順序を示す。Numbers indicate sequence in which the tests are performed

4. 付図

4. Figure

4.1 ローレベル総合抵抗

4.1 Low Level Resistance

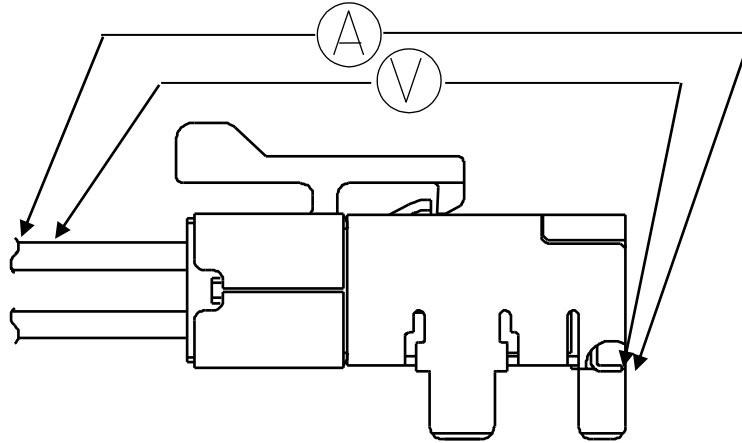

Fig. 3 ローレベル総合抵抗測定
Fig.3 Low-Level Termination Resistance Measurement

4.2 ケーブル屈曲

4.2 Cable Flex

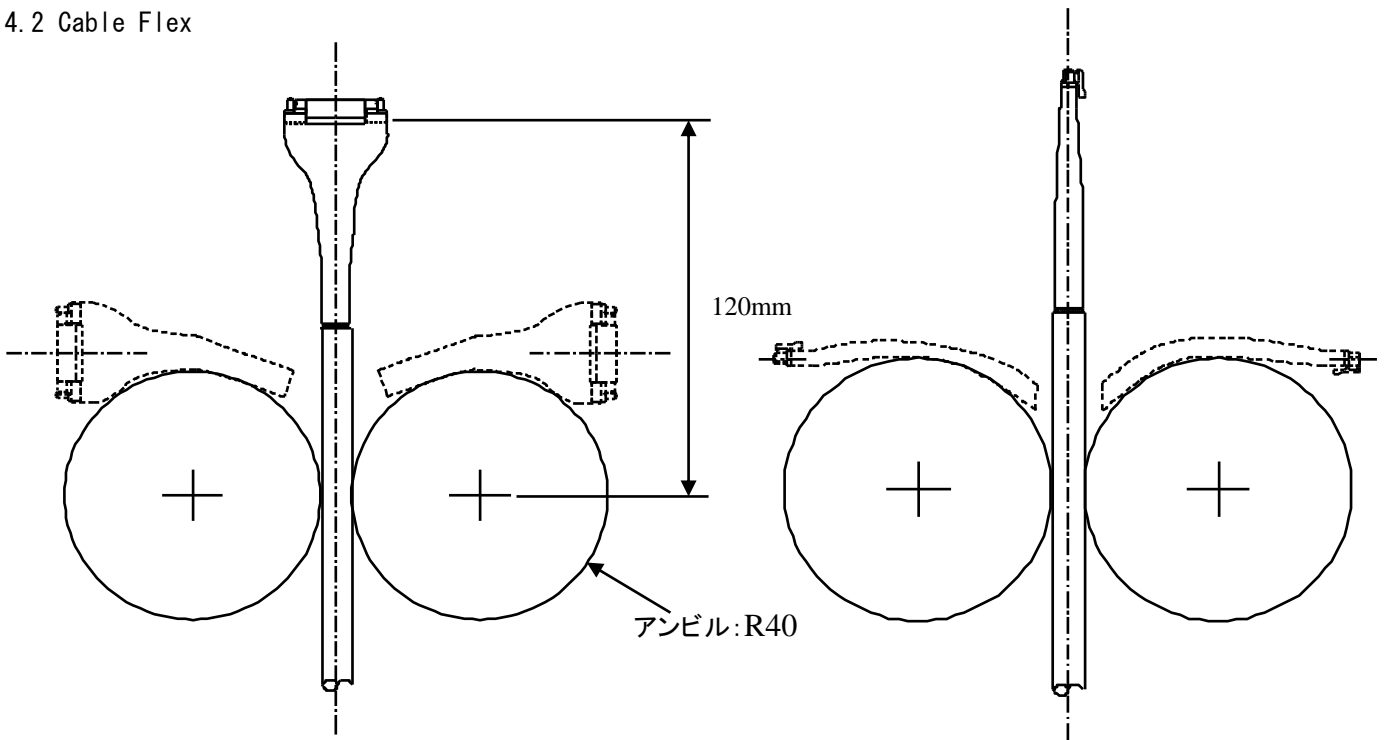

Fig. 4 ケーブル屈曲
Fig. 4 Cable Flex

4.3 リフロー半田の温度プロファイル

4.3 Temperature profile of reflow soldering

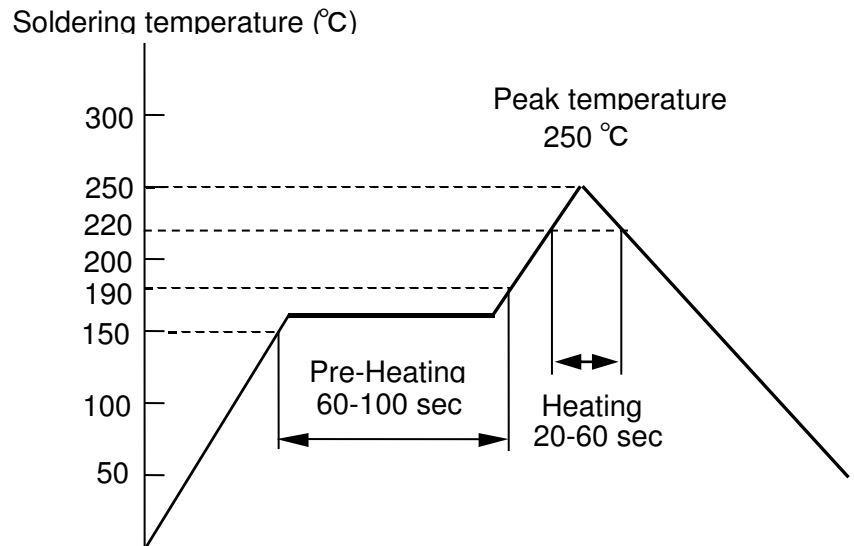

Fig.5 リフロー半田の温度プロファイル
Fig.5 Temperature Profile of Reflow Soldering

5. 測定結果 TEST RESULT

条件 Conditions	測定項目 Measure Item	n	単位 Unit	結果 Results				規格 Requirement	判定 Judgment
				MAX.	MIN.	AVE.	SIG.		
試験グループ 1 耐電圧/絶縁抵抗 Test Group 1 Dielectric Withstanding Voltage/ Insulation Resistance									
EXTERNAL R/A Type 50p									
初期 Initial	耐電圧 Dielectric Strength	10 Point	—	異常なし No abnormalities				異常なきこと No Abnormalities	合格 Acceptable
初期 Initial	耐電圧 Dielectric Strength	3	—	1 × 10 ⁹ Ω Min.				100 × 10 ⁶ Ω Min.	合格 Acceptable
INTERNAL R/A Type 50p									
初期 Initial	耐電圧 Dielectric Strength	10 Point	—	異常なし No abnormalities				異常なきこと No Abnormalities	合格 Acceptable
初期 Initial	耐電圧 Dielectric Strength	3	—	1 × 10 ⁹ Ω Min.				100 × 10 ⁶ Ω Min.	合格 Acceptable
INTERNAL V Type 50p									
初期 Initial	耐電圧 Dielectric Strength	10 Point	℃	異常なし No abnormalities				異常なきこと No Abnormalities	合格 Acceptable
初期 Initial	耐電圧 Dielectric Strength	3	—	1 × 10 ⁹ Ω Min.				100 × 10 ⁶ Ω Min.	合格 Acceptable

条件 Conditions	測定項目 Measure Item	n	単位 Unit	結果 Results				規格 Requirement	判定 Judgment
				MAX.	MIN.	AVE.	SIG.		
試験グループ 2 ・温度上昇 Test Group 2 ・Temperature Rising									
EXTERNAL R/A Type 50p									
温度上昇値 (全極通電) Temperature rise (All positions)	DC 0.2A	3	°C	3.10				-	-
	DC 0.3A	3	°C	3.90				-	-
	DC 0.5A	3	°C	9.20				30°C Max.	合格 Acceptable
	DC 0.7A	3	°C	17.0				-	-
INTERNAL R/A Type 50p									
温度上昇値 (全極通電) Temperature rise (All positions)	DC 0.2A	3	°C	6.70				-	-
	DC 0.3A	3	°C	10.50				-	-
	DC 0.5A	3	°C	25.10				30°C Max.	合格 Acceptable
	DC 0.7A	3	°C	35.60				-	-
INTERNAL V Type 50p									
温度上昇値 (全極通電) Temperature rise (All positions)	DC 0.2A	3	°C	4.10				-	-
	DC 0.3A	3	°C	6.10				-	-
	DC 0.5A	3	°C	14.90				30°C Max.	合格 Acceptable
	DC 0.7A	3	°C	25.40				-	-

条件 Conditions	測定項目 Measure Item	n	単位 Unit	結果 Results				規格 Requirement	判定 Judgment
				MAX.	MIN.	AVE.	SIG.		
試験グループ 3・4 ・コネクタ挿入力/コネクタ引抜き力 Test group 3・4 ・Connector Mating Force/ Connector Unmating Force									
EXTERNAL R/A Type 50p									
コネクタ挿入力 Connector Mating Force		3	N	22.4	21.2	22.4	1.08	55N Max	合格 Acceptable
コネクタ引抜き力 Connector Unmating Force		3	N	8.9	12.1	8.26	0.78	3N Min 55N Max	合格 Acceptable
INTERNAL R/A Type 50p									
コネクタ挿入力 Connector Mating Force		3	N	25.9	24.6	25.2	0.66	55N Max	合格 Acceptable
コネクタ引抜き力 Connector Unmating Force		3	N	9.2	7.6	8.36	0.80	3N Min 55N Max	合格 Acceptable
INTERNAL V Type 50p									
コネクタ挿入力 Connector Mating Force		3	N	26.1	24.8	25.43	0.65	55N Max	合格 Acceptable
コネクタ引抜き力 Connector Unmating Force		3	N	8.5	7.3	7.9	0.60	3N Min 55N Max	合格 Acceptable

条件 Conditions	測定項目 Measure Item	n	単位 Unit	結果 Results				規格 Requirement	判定 Judgment
				MAX.	MIN.	AVE.	SIG.		
試験グループ 5 ・耐久性(繰り返し挿抜) Test group 5 ・Durability (Repeated Mate / Unmating)									
EXTERNAL R/A Type 50p									
初期 Initial	総合抵抗 Termination Resistance	150	mΩ	17.02	8.98	14.61	1.63	40mΩ Max	合格 Acceptable
試験後 Final	総合抵抗 Termination Resistance	150	mΩ	17.26	9.67	15.40	1.37	-	-
	ΔR	150	mΩ	2.80	-1.53	0.79	0.85	20mΩ Max	合格 Acceptable
INTERNAL R/A Type 50p									
初期 Initial	総合抵抗 Termination Resistance	150	mΩ	11.06	6.92	9.88	1.37	40mΩ Max	合格 Acceptable
試験後 Final	総合抵抗 Termination Resistance	150	mΩ	11.99	6.61	9.59	1.26	-	-
	ΔR	150	mΩ	2.19	-1.53	0.71	0.83	20mΩ Max	合格 Acceptable
INTERNAL V Type 50p									
初期 Initial	総合抵抗 Termination Resistance	150	mΩ	11.03	6.77	8.82	1.40	40mΩ Max	合格 Acceptable
試験後 Final	総合抵抗 Termination Resistance	150	mΩ	11.99	6.46	9.61	1.12	-	-
	ΔR	150	mΩ	2.80	-1.53	0.79	0.85	20mΩ Max	合格 Acceptable
試験グループ 6 ・ロック強度 Test group 6 ・Lock Strength									
INTERNAL R/A Type 50p									
ロック強度 Lock Strength		3	N	46.3	39.2	42.36	3.61	30N Min	合格 Acceptable
INTERNAL V Type 50p									
ロック強度 Lock Strength		3	N	47.1	43.6	45.53	1.78	30N Min	合格 Acceptable

条件 Conditions	測定項目 Measure Item	n	単位 Unit	結果 Results				規格 Requirement	判定 Judgment
				MAX.	MIN.	AVE.	SIG.		
試験グループ 7 ・圧着端子保持力 Test group7 ・Crimp Contact Retention Force									
External Cable Assy									
圧着端子保持力 Crimp Contact Retention Force		150	N	9.5	8.2	8.79	0.30	7N Min	合格 Acceptable
INTERNAL Cable Assy									
圧着端子保持力 Crimp Contact Retention Force		150	N	9.6	8.3	8.87	0.29	7N Min	合格 Acceptable
試験グループ 8 ・圧着部引張強度 Test group8 ・Crimp Tensile Strength									
圧着部引張強度 (AWG#30) Crimp Tensile Strength (AWG#30)		150	N	18.5	15.4	16.8	0.13	9.8N Min	合格 Acceptable

条件 Conditions	測定項目 Measure Item	n	単位 Unit	結果 Results				規格 Requirement	判定 Judgment
				MAX.	MIN.	AVE.	SIG.		
試験グループ 9 ・振動(低周波) Test group 9 ・Vibration (Low Frequency)									
EXTERNAL R/A Type 50p									
初期 Initial	総合抵抗 Termination Resistance	150	mΩ	18.32	11.54	16.23	1.48	40mΩ Max	合格 Acceptable
試験中 During test	瞬断 Circuit Continuity	150	μS	瞬断なし No discontinuity				0.1 μS Max.	合格 Acceptable
終期 Final	総合抵抗 Termination Resistance	150	mΩ	16.83	12.77	16.84	1.28	-	-
	ΔR	150	mΩ	2.63	-2.27	0.81	1.30	20mΩ Max	合格 Acceptable
INTERNAL R/A Type 50p									
初期 Initial	総合抵抗 Termination Resistance	150	mΩ	14.64	9.59	12.13	1.64	40mΩ Max	合格 Acceptable
試験中 During test	瞬断 Circuit Continuity	150	μS	瞬断なし No discontinuity				0.1 μS Max.	合格 Acceptable
終期 Final	総合抵抗 Termination Resistance	150	mΩ	16.31	7.89	10.27	1.45	-	-
	ΔR	150	mΩ	2.75	-2.93	0.58	1.42	20mΩ Max	合格 Acceptable
INTERNAL V Type 50p									
初期 Initial	総合抵抗 Termination Resistance	150	mΩ	13.52	8.17	11.06	1.77	40mΩ Max	合格 Acceptable
試験中 During test	瞬断 Circuit Continuity	150	μS	瞬断なし No discontinuity				0.1 μS Max.	合格 Acceptable
終期 Final	総合抵抗 Termination Resistance	150	mΩ	15.72	7.83	10.19	1.46	-	-
	ΔR	150	mΩ	0.99	-3.72	0.37	1.52	20mΩ Max	合格 Acceptable

条件 Conditions	測定項目 Measure Item	n	単位 Unit	結果 Results				規格 Requirement	判定 Judgment
				MAX.	MIN.	AVE.	SIG.		
試験グループ 10 ・衝撃 Test group 10 ・Physical Shock									
EXTERNAL R/A Type 50p									
初期 Initial	総合抵抗 Termination Resistance	150	mΩ	17.51	8.94	13.65	1.62	40mΩ Max	合格 Acceptable
試験中 During test	瞬断 Circuit Continuity	150	μS	瞬断なし No discontinuity				0.1 μS Max.	合格 Acceptable
終期 Final	総合抵抗 Termination Resistance	150	mΩ	17.72	9.55	13.42	1.28	-	-
	ΔR	150	mΩ	1.94	-0.46	0.95	1.06	20mΩ Max	合格 Acceptable
INTERNAL R/A Type 50p									
初期 Initial	総合抵抗 Termination Resistance	150	mΩ	13.61	7.94	9.81	1.39	40mΩ Max	合格 Acceptable
試験中 During test	瞬断 Circuit Continuity	150	μS	瞬断なし No discontinuity				0.1 μS Max.	合格 Acceptable
終期 Final	総合抵抗 Termination Resistance	150	mΩ	14.32	7.43	10.79	1.26	-	-
	ΔR	150	mΩ	2.09	-1.22	0.79	1.08	20mΩ Max	合格 Acceptable
INTERNAL V Type 50p									
初期 Initial	総合抵抗 Termination Resistance	150	mΩ	13.29	7.26	9.85	1.43	40mΩ Max	合格 Acceptable
試験中 During test	瞬断 Circuit Continuity	150	μS	瞬断なし No discontinuity				0.1 μS Max.	合格 Acceptable
終期 Final	総合抵抗 Termination Resistance	150	mΩ	12.46	6.77	9.52	1.26	-	-
	ΔR	150	mΩ	2.43	-1.78	0.83	0.98	20mΩ Max	合格 Acceptable

条件 Conditions	測定項目 Measure Item	n	単位 Unit	結果 Results				規格 Requirement	判定 Judgment
				MAX.	MIN.	AVE.	SIG.		
試験グループ 11 ・はんだ付け性 Test group 11 ・Solderability									
EXTERNAL R/A Type 50p									
平衡法 Wetting balance method	ゼロクロス時 間 Zero cross time	10	N	1.46	0.34	0.759	0.465	3 sec. Max.	合格 Acceptable
INTERNAL R/A Type 50p									
平衡法 Wetting balance method	ゼロクロス時 間 Zero cross time	10	N	1.11	0.21	0.603	0.381	3 sec. Max.	合格 Acceptable
INTERNAL V Type 50p									
平衡法 Wetting balance method	ゼロクロス時 間 Zero cross time	10	N	1.25	0.25	0.518	0.394	3 sec. Max.	合格 Acceptable
試験グループ 12 ・ケーブル屈曲 Test group 12 ・Cable Flex									
External Cable Assy									
ケーブル屈曲 Cable Flex		5	—	異常なし No abnormalities				異常なきこと No Abnormalities	合格 Acceptable
Internal Cable Assy									
ケーブル屈曲 Cable Flex		5	—	異常なし No abnormalities				異常なきこと No Abnormalities	合格 Acceptable

条件 Conditions	測定項目 Measure Item	n	単位 Unit	結果 Results				規格 Requirement	判定 Judgment
				MAX.	MIN.	AVE.	SIG.		
試験グループ 13 ・はんだ耐熱性 Test group13 ・Resistance to soldering heat									
EXTERNAL R/A Type 50p									
リフローソルダリング Reflow soldering フローソルダリング Flow soldering 手はんだ Manual soldering		10	—	異常なし No abnormalities				異常なきこと No Abnormalities	合格 Acceptable
INTERNAL R/A Type 50p									
リフローソルダリング Reflow soldering フローソルダリング Flow soldering 手はんだ Manual soldering		10	—	異常なし No abnormalities				異常なきこと No Abnormalities	合格 Acceptable
INTERNAL V Type 50p									
リフローソルダリング Reflow soldering フローソルダリング Flow soldering 手はんだ Manual soldering		10	—	異常なし No abnormalities				異常なきこと No Abnormalities	合格 Acceptable

条件 Conditions	測定項目 Measure Item	n	単位 Unit	結果 Results				規格 Requirement	判定 Judgment
				MAX.	MIN.	AVE.	SIG.		
試験グループ 14 ・耐寒性 Test group 14 ・Cold									
EXTERNAL R/A Type 50p									
初期 Initial	総合抵抗 Termination Resistance	150	mΩ	16.34	9.87	14.05	1.68	40mΩ Max	合格 Acceptable
終期 Final	総合抵抗 Termination Resistance	150	mΩ	16.89	9.26	14.67	1.85	-	-
	ΔR	150	mΩ	2.53	-0.61	0.61	0.72	20mΩ Max	合格 Acceptable
INTERNAL R/A Type 50p									
初期 Initial	総合抵抗 Termination Resistance	150	mΩ	11.25	6.63	8.84	1.32	40mΩ Max	合格 Acceptable
終期 Final	総合抵抗 Termination Resistance	150	mΩ	11.91	6.04	9.03	1.51	-	-
	ΔR	150	mΩ	2.53	-1.13	0.58	0.76	20mΩ Max	合格 Acceptable
INTERNAL V Type 50p									
初期 Initial	総合抵抗 Termination Resistance	150	mΩ	11.33	6.22	8.48	1.17	40mΩ Max	合格 Acceptable
終期 Final	総合抵抗 Termination Resistance	150	mΩ	11.99	5.80	9.06	1.32	-	-
	ΔR	150	mΩ	2.36	-0.61	0.58	0.66	20mΩ Max	合格 Acceptable

条件 Conditions	測定項目 Measure Item	n	単位 Unit	結果 Results				規格 Requirement	判定 Judgment
				MAX.	MIN.	AVE.	SIG.		
試験グループ 15 ・耐熱性 Test group 15 ・Dry Heat									
EXTERNAL R/A Type 50p									
初期 Initial	総合抵抗 Termination Resistance	150	mΩ	16.91	10.36	14.38	1.32	40mΩ Max	合格 Acceptable
終期 Final	総合抵抗 Termination Resistance	150	mΩ	16.52	11.29	14.87	1.07	-	-
	ΔR	150	mΩ	2.16	-1.41	0.50	0.83	20mΩ Max	合格 Acceptable
INTERNAL R/A Type 50p									
初期 Initial	総合抵抗 Termination Resistance	150	mΩ	11.12	6.30	8.57	1.20	40mΩ Max	合格 Acceptable
終期 Final	総合抵抗 Termination Resistance	150	mΩ	10.69	7.23	9.06	0.95	-	-
	ΔR	150	mΩ	2.16	-1.41	0.50	0.83	20mΩ Max	合格 Acceptable
INTERNAL V Type 50p									
初期 Initial	総合抵抗 Termination Resistance	150	mΩ	10.95	6.34	8.56	1.19	40mΩ Max	合格 Acceptable
終期 Final	総合抵抗 Termination Resistance	150	mΩ	10.89	7.42	9.05	0.92	-	-
	ΔR	150	mΩ	2.16	-1.41	0.50	0.83	20mΩ Max	合格 Acceptable

条件 Conditions	測定項目 Measure Item	n	単位 Unit	結果 Results				規格 Requirement	判定 Judgment
				MAX.	MIN.	AVE.	SIG.		
試験グループ 16 ・耐湿性(定常状態) Test group 16 ・Damp Heat(Steady State)									
EXTERNAL R/A Type 50p									
初期 Initial	総合抵抗 Termination Resistance	150	mΩ	16.32	9.94	14.30	1.57	40mΩ Max	合格 Acceptable
耐湿後 After Damp Heat	耐電圧 Dielectric Strength	10 Point	—	異常なし No abnormalities				異常なきこと No Abnormalities	合格 Acceptable
耐湿後 After Damp Heat	絶縁抵抗 Insulation Resistance	3	—	1 × 10 ⁹ Ω Min.				50 × 10 ⁶ Ω Min.	合格 Acceptable
終期 Final	総合抵抗 Termination Resistance	150	mΩ	16.78	9.71	14.90	1.49	-	-
	ΔR	150	mΩ	1.51	-0.89	0.60	0.48	20mΩ Max	合格 Acceptable
INTERNAL R/A Type 50p									
初期 Initial	総合抵抗 Termination Resistance	150	mΩ	10.37	6.78	8.35	1.25	40mΩ Max	合格 Acceptable
耐湿後 After Damp Heat	耐電圧 Dielectric Strength	10 Point	—	異常なし No abnormalities				異常なきこと No Abnormalities	合格 Acceptable
耐湿後 After Damp Heat	絶縁抵抗 Insulation Resistance	3	—	1 × 10 ⁹ Ω Min.				50 × 10 ⁶ Ω Min.	合格 Acceptable
終期 Final	総合抵抗 Termination Resistance	150	mΩ	11.07	6.46	9.12	1.36	-	-
	ΔR	150	mΩ	3.93	-2.93	0.77	1.77	20mΩ Max	合格 Acceptable
INTERNAL V Type 50p									
初期 Initial	総合抵抗 Termination Resistance	150	mΩ	10.61	6.24	8.67	1.11	40mΩ Max	合格 Acceptable
耐湿後 After Damp Heat	耐電圧 Dielectric Strength	10 Point	—	異常なし No abnormalities				異常なきこと No Abnormalities	合格 Acceptable
耐湿後 After Damp Heat	絶縁抵抗 Insulation Resistance	3	—	1 × 10 ⁹ Ω Min.				50 × 10 ⁶ Ω Min.	合格 Acceptable
終期 Final	総合抵抗 Termination Resistance	150	mΩ	11.16	6.25	9.27	1.07	-	-
	ΔR	150	mΩ	1.51	-0.89	0.60	0.48	20mΩ Max	合格 Acceptable

条件 Conditions	測定項目 Measure Item	n	単位 Unit	結果 Results				規格 Requirement	判定 Judgment
				MAX.	MIN.	AVE.	SIG.		
試験グループ 17 ・温度サイクル Test group 17 ・Temperature Cycle									
EXTERNAL R/A Type 50p									
初期 Initial	総合抵抗 Termination Resistance	150	mΩ	16.35	9.87	14.64	1.48	40mΩ Max	合格 Acceptable
終期 Final	総合抵抗 Termination Resistance	150	mΩ	16.89	10.06	15.31	1.41	-	-
	ΔR	150	mΩ	2.16	-1.60	0.67	0.84	20mΩ Max	合格 Acceptable
INTERNAL R/A Type 50p									
初期 Initial	総合抵抗 Termination Resistance	150	mΩ	10.64	6.81	8.88	1.19	40mΩ Max	合格 Acceptable
終期 Final	総合抵抗 Termination Resistance	150	mΩ	11.18	6.90	9.50	1.24	-	-
	ΔR	150	mΩ	2.16	-1.60	0.62	0.82	20mΩ Max	合格 Acceptable
INTERNAL V Type 50p									
初期 Initial	総合抵抗 Termination Resistance	150	mΩ	10.51	6.32	8.92	1.06	40mΩ Max	合格 Acceptable
終期 Final	総合抵抗 Termination Resistance	150	mΩ	10.95	6.85	9.55	1.05	-	-
	ΔR	150	mΩ	2.13	-1.60	0.64	0.81	20mΩ Max	合格 Acceptable

条件 Conditions	測定項目 Measure Item	n	単位 Unit	結果 Results				規格 Requirement	判定 Judgment
				MAX.	MIN.	AVE.	SIG.		
試験グループ 18 ・塩水噴霧 Test group 18 ・Salt Spray									
EXTERNAL R/A Type 50p									
初期 Initial	総合抵抗 Termination Resistance	150	mΩ	17.34	12.09	14.66	1.49	40mΩ Max	合格 Acceptable
終期 Final	総合抵抗 Termination Resistance	150	mΩ	17.90	11.03	14.22	1.36	-	-
	ΔR	150	mΩ	3.87	-4.50	0.80	1.84	20mΩ Max	合格 Acceptable
INTERNAL R/A Type 50p									
初期 Initial	総合抵抗 Termination Resistance	150	mΩ	12.47	6.49	9.52	1.43	40mΩ Max	合格 Acceptable
終期 Final	総合抵抗 Termination Resistance	150	mΩ	11.99	6.31	9.53	1.28	-	-
	ΔR	150	mΩ	2.43	-0.94	0.78	0.92	20mΩ Max	合格 Acceptable
INTERNAL V Type 50p									
初期 Initial	総合抵抗 Termination Resistance	150	mΩ	11.62	6.83	9.26	1.52	40mΩ Max	合格 Acceptable
終期 Final	総合抵抗 Termination Resistance	150	mΩ	12.43	6.49	9.05	1.26	-	-
	ΔR	150	mΩ	3.76	-2.35	0.84	1.31	20mΩ Max	合格 Acceptable

条件 Conditions	測定項目 Measure Item	n	単位 Unit	結果 Results				規格 Requirement	判定 Judgment
				MAX.	MIN.	AVE.	SIG.		
試験グループ 19 ・工業ガス(SO2) Test group 19 ・Industrial Gas(SO2)									
EXTERNAL R/A Type 50p									
初期 Initial	総合抵抗 Termination Resistance	150	mΩ	17.43	11.07	14.26	1.45	40mΩ Max	合格 Acceptable
終期 Final	総合抵抗 Termination Resistance	150	mΩ	17.22	11.29	14.85	1.24	-	-
	ΔR	150	mΩ	2.34	-0.89	0.95	0.95	20mΩ Max	合格 Acceptable
INTERNAL R/A Type 50p									
初期 Initial	総合抵抗 Termination Resistance	150	mΩ	11.46	6.88	9.31	1.35	40mΩ Max	合格 Acceptable
終期 Final	総合抵抗 Termination Resistance	150	mΩ	10.47	7.20	8.86	1.14	-	-
	ΔR	150	mΩ	2.64	-0.88	0.84	1.19	20mΩ Max	合格 Acceptable
INTERNAL V Type 50p									
初期 Initial	総合抵抗 Termination Resistance	150	mΩ	10.97	6.78	8.63	1.11	40mΩ Max	合格 Acceptable
終期 Final	総合抵抗 Termination Resistance	150	mΩ	11.47	7.78	9.29	0.92	-	-
	ΔR	150	mΩ	2.13	-0.73	0.97	1.04	20mΩ Max	合格 Acceptable

条件 Conditions	測定項目 Measure Item	n	単位 Unit	結果 Results				規格 Requirement	判定 Judgment
				MAX.	MIN.	AVE.	SIG.		
試験グループ 20 ・耐湿性(温湿度サイクル) Test group 20 ・Composite temperature (Humidity Cyclic Test)									
EXTERNAL R/A Type 50p									
初期 Initial	総合抵抗 Termination Resistance	150	mΩ	16.91	10.36	14.38	1.32	40mΩ Max	合格 Acceptable
終期 Final	総合抵抗 Termination Resistance	150	mΩ	16.96	12.09	15.07	1.07	-	-
	ΔR	150	mΩ	1.82	-0.73	0.70	0.56	20mΩ Max	合格 Acceptable
INTERNAL R/A Type 50p									
初期 Initial	総合抵抗 Termination Resistance	150	mΩ	11.09	7.51	8.93	1.26	40mΩ Max	合格 Acceptable
終期 Final	総合抵抗 Termination Resistance	150	mΩ	11.24	7.32	9.51	1.16	-	-
	ΔR	150	mΩ	1.72	-0.75	0.78	0.81	20mΩ Max	合格 Acceptable
INTERNAL V Type 50p									
初期 Initial	総合抵抗 Termination Resistance	150	mΩ	10.82	6.98	8.72	1.29	40mΩ Max	合格 Acceptable
終期 Final	総合抵抗 Termination Resistance	150	mΩ	11.21	6.59	8.49	1.13	-	-
	ΔR	150	mΩ	2.05	-0.66	0.89	0.86	20mΩ Max	合格 Acceptable