

PRELIMINARY

1. Part Name and Part Number

1.1 Housing

Part Number*	Part Name
1746166	0.50 Series 40Pos. Cap Housing Assembly (Male Connector)
1746170	0.50 Series 40Pos. Plug Housing Assembly (Female Connector)

Fig.1

*Note: Part number is consisted from listed base number and 1 digit numeric prefix and suffix with dash. Refer to catalog or customer drawing for specific part numbers for each base number. When prefix is zero, zero and dash are omitted.

1.2 Contact

Part Number	Part Name	Wire Type (○ : Applicable, — : Not Applicable)			
		Type	0.22	0.35	0.5
1674194	0.50 Receptacle (Female Contact)	CHFUS	○	○	—
		CHFS	—	—	—
		HFSS	—	—	—

Fig.2

1.3 Components View

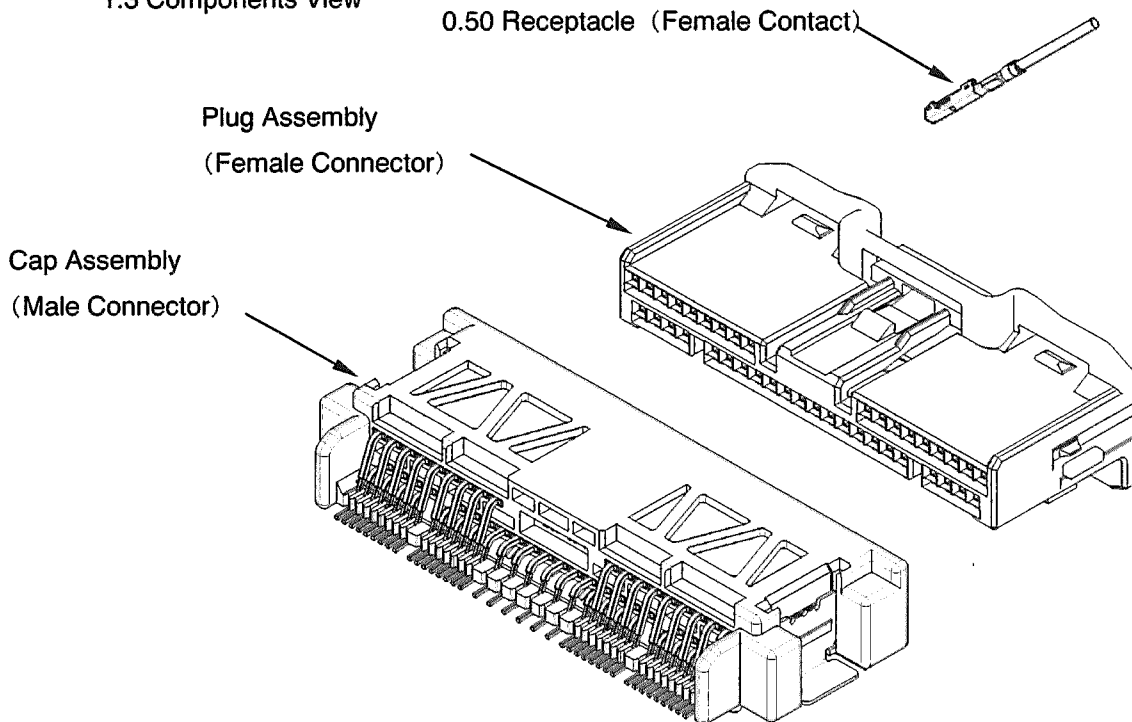

Fig.3

PRELIMINARY

1. Customer Receiving Inspection

2.1 Preshipment Inspection by TYCO Electronics AMP K.K.

All the preshipment inspection by TYCO Electronics AMP K.K. are carried put for each shipment lot based on the quality control rules and applicable standards by means of the statistical control method. As a general rule, the manufacturing date is shown on each of the comparisons with the inspection records, manufacturing records, and adjustment records for the machines and measurement instruments. Note that the manufacturing date is shown using a date code specified below.

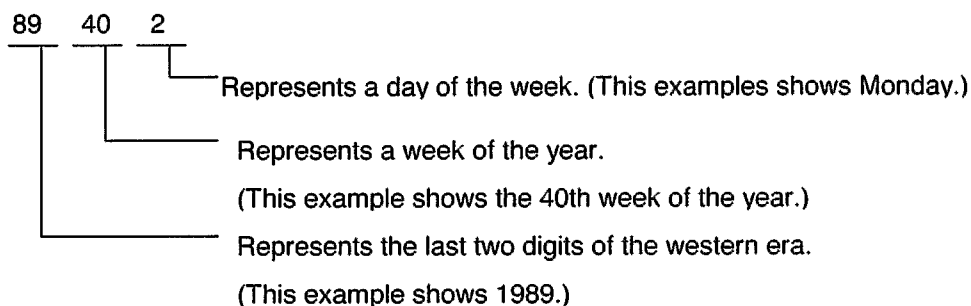

2.2 Customer 's Receiving Inspection:

Although, the products are thoroughly inspected before delivery, it is recommended that the customer be attentive to confirm the status of products, to check out if the products incurred any damage during transit.

<Receptacle Contacts(Female Contact)>

Item	Check Points	Measuring Apparatus
Visual Inspection	(1)Configuration and Appearance	Visual
	(2)Plating Finish	Visual
	(3)Reeling Status of Strip Terminals	Visual
Dimensional Inspection	(1)Width and Height of Wire Barrel	Calipers
	(2)Width and Height of Insulation Barrel	Calipers

Upon Receiving, the reeled terminal products should be classified by manufacturing date codes and put under the inspection in accordance with the inspection level II of MIL-STD -105 at acceptable quality level of 4.0%, visually and dimensionally to check the first five terminals in reel.

Acceptable of the products is verified by proving the products meeting the specified requirements.

PRELIMINARY

<Plug Assembly , Cap Assembly>

Item	Check Points	Measuring Apparatus
Appearance	(1)Burrs, Discoloration & Deformation	Visual
Inspection	(2)Cracks, Breakage & Chipping off	Visual
Functional Inspection	(1)Mating Check to see if the connector mate and unmate smoothly with suitable housing.	Tactual

The product housings submitted to inspection, are classified by manufacturing date codes and put under the inspection in accordance with the inspection level II of MIL-STD -105 at acceptable quality level of 4.0%, visually and functionally to the randomly selected five pieced out of the lot.

Acceptable of the products is verified by proving the products meeting the specified requirements.

3. Storage and Carrying

3.1 Contact

- (1) Avoid leaving or carrying the contact reel in an open area without wrapping it in proper material.
- (2) Do not lift up and carry the contact reel by gripping one the side of reel, this may result in damage to the reel, and contacts before use. (See Fig.4)

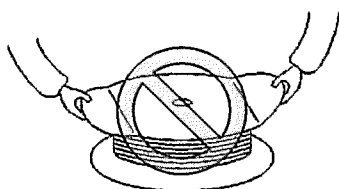

Do not lift up laterally holding one side only.



Acceptable

Fig.4

- (3) Avoid storing the contact reel in a moist or dusty place. Stock the reel in a comparatively dry and clean place (5~35°C, 45~85%RH) away from direct sunlight.
- (4) When removing the contact reel from the machine, fasten the end of contact strip onto the edge of the reel with use of proper string or wire. (See Fig.5)

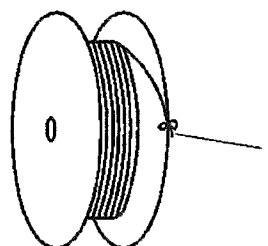

Tie strip end with a wire neatly

Fig.5

3.2 Plug Housing Assembly, Cap Housing Assembly

- (1) Avoid storing the contact reel in a moist or dusty place. Stock the reel in a comparatively dry and clean place (5~35°C, 45~85%RH) away from direct sunlight.

PRELIMINARY

- (2) Avoid leaving or carrying the contact reel in an open area without wrapping it in proper material.
- (3) Do not drop or shock the housing when carrying it.

4. Installation of male connector to P.C.B.

Check the following item before installation.

- (1) Soldering Process
 - Reflow soldering
- (2) Recommendation attachment P.C.B. dimension.
 - Refer to the drawing of an appropriate product.
- (3) P.C.B.
 - In the case of curvature large to P.C.B, soldering may become poor.
 - Be careful of reflow condition and material of P.C.B.
- (4) Solder paste thickness
 - 0.15mm Min. In the case of 0.15mm Max. ,soldering may become poor.

Be careful of the following points in the case of work.

- (1) The extraction process from packing tube
 - Be careful of deformation of lead , solder-peg. Please discard, When a form changes
- (2) P.C.B. arrangement process.
 - Please arrange so that the boss for positioning goes into the hole for bosses of P.C.B.
 - In case you separate a connector from mount, be careful for lead solder-peg deformation by shock.
- (3) Reflow soldering process
 - Be careful of discoloration of a connector, deformation, etc by heat.
 - If the temperature of housing is heated at 260°C Min, housing has the fusion possibility.
 - Reflow is restricted at one time.
 - <Reference conditions>
 - Pre-Heat : 170~190°C 110sec Min.
 - Soldering : 200°C 70sec Max.
 - Peak Temperature: 245°C Min.
 - Solder : Sn-Ag-Cu Solder Paste
- (4) After reflow
 - Check that there are not discoloration of a connector, deformation, etc.
 - Please check being soldered of all leads and a peg.
- (5) Others
 - Please be careful of deformation and damage of lead (matting side, P.C.B side) and solder-peg housing. and Mixing of a substance, adhesion in mating points.

PRELIMINARY

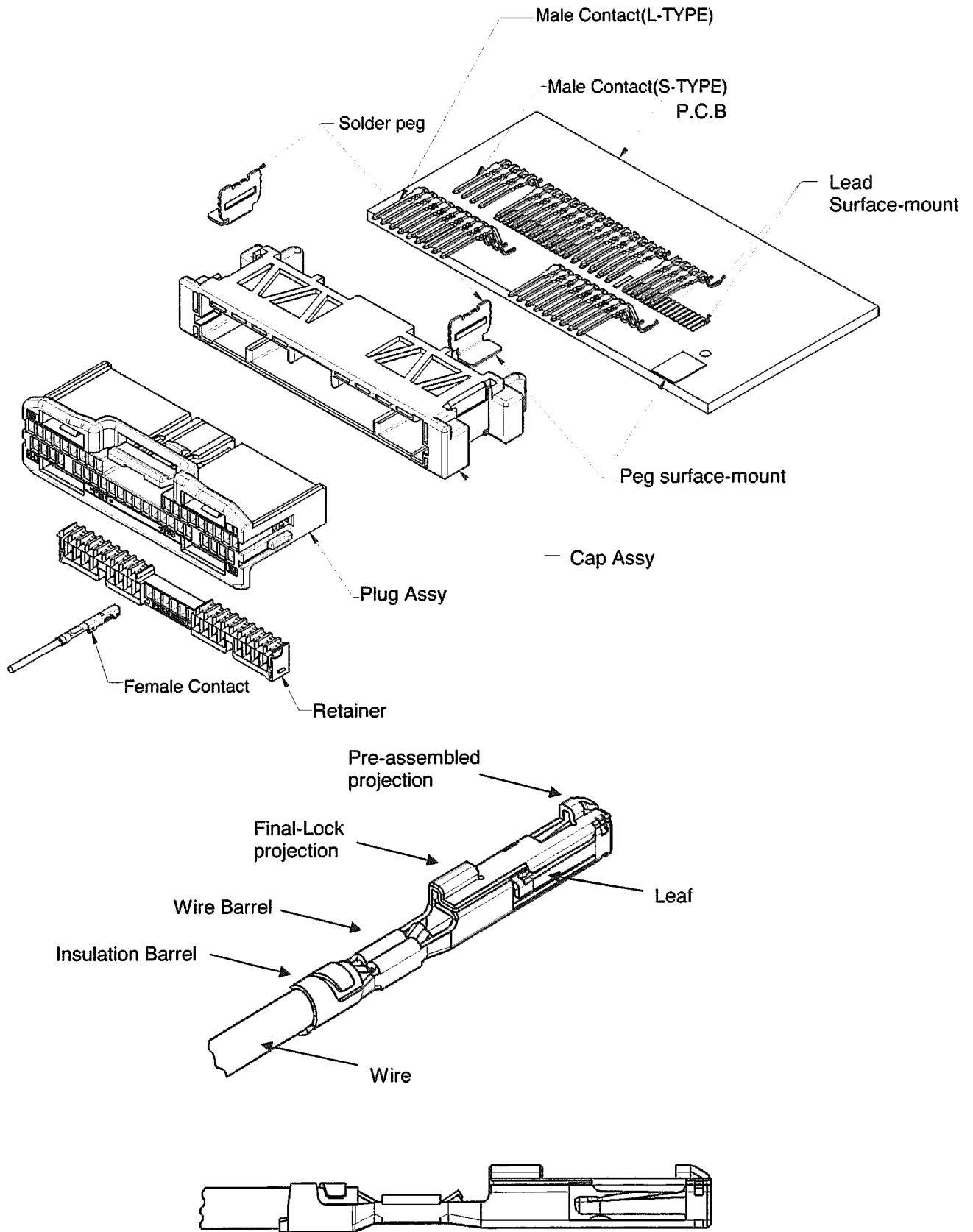

Fig.6

PRELIMINARY

5. Crimping Operation

Any crimping of contacts must be performed by using appropriate AMP tools according to the applicable Instruction Sheet and Specification.

5.1 Wire

5.1.1 Applicable Wire

See Fig.2 for applicable wire.

5.1.2 Notes for Stripping of Wire End

Wire end must be stripped without nick, cutoff, or damage of wire strands.

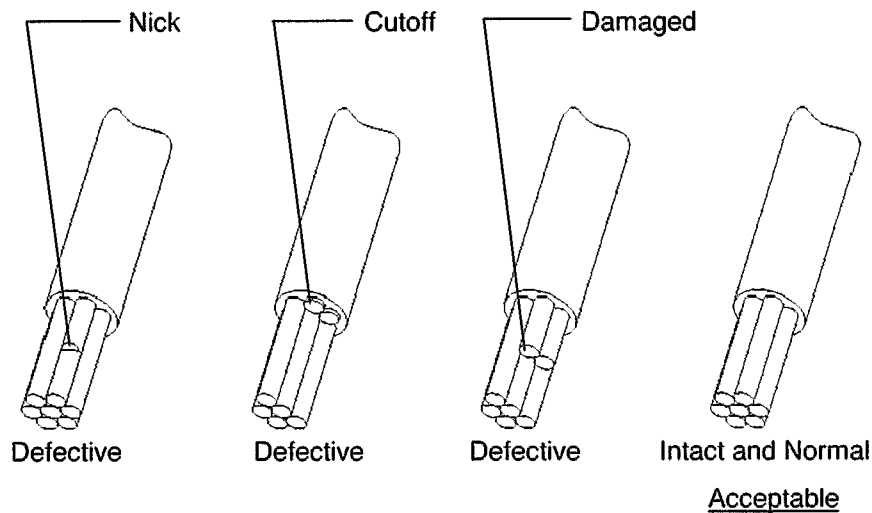

Fig.7

5.2 Operation of Crimping Machine

In the case of "0.50 Tab & Receptacle Contact", see instruction sheet "412-5022(separate volume)" for automatic terminating machine.

5.3 Crimping Specification

In the case of "0.50 Receptacle Contact", see application specification "114-5341(separate volume)".

5.4 Storage and Handling of Crimped Products

- (1) Store the products in a clean, dry area, cover with proper sheet or paper when placed in an open area until the next day.
- (2) Crimped leads should be processed in bundles of less than 100 pieces. In addition, care should be taken in case the leads catch together or be tangled, causing damage of the products(Specially the Leaf 0.50 Receptacle Contact).
- (3) Avoid stacking and piling up the in-process products in large volume. Deformation of the contact and 025 receptacle's lance will result in malfunction of contacting parts electrically.

PRELIMINARY

6. Harness Making

6.1 Procedure for Female Contact Insertion into Housing

- (1) Confirm the retainer is in pre-assembled condition. When the retainer is in final lock condition, it must be unlocked to pre-assembled condition. See para.6.3. The contact can not be inserted in final lock condition.

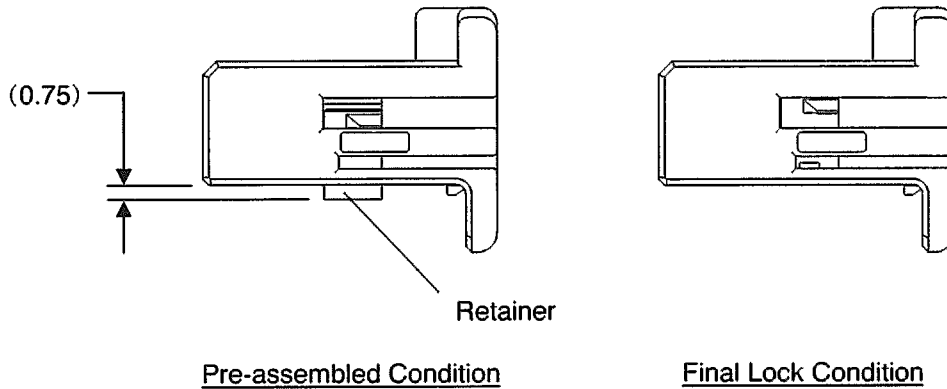

Fig.8

- (2) Confirm type of contact and housing.

It must be the same type of contact and housing (Insert the male contact to the male housing and the female contact to the female housing).

NOTE Should not insert the contact to different type housing.

If you insert different type, the contact and housing should be exchanged, not use.

- (3) Confirm the contact size. The cavity size of the housing can be identified by the shape of cavities. See the customer drawings to know the construction of cavities.

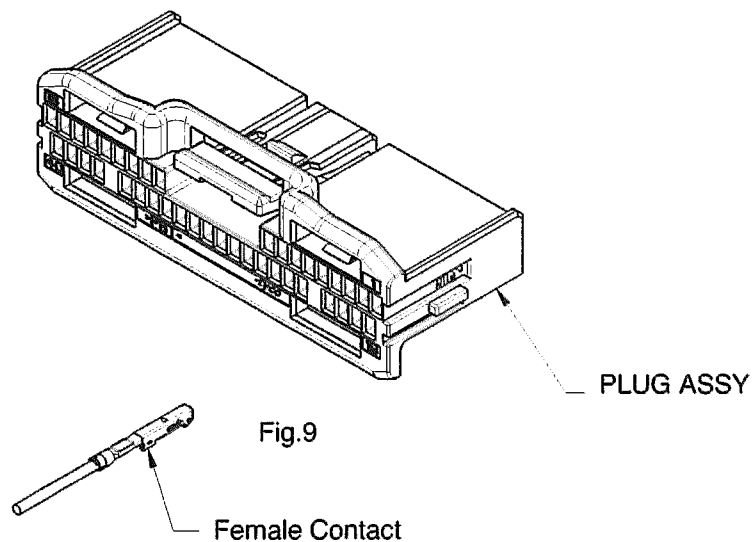

Fig.9

- (4) By pulling the contact by 10N MAX, check to make sure that the contact can not be withdrawn.

PRELIMINARY

6.2 Double Lock (Secondary Lock) Operation

- (1) After insertion of all of the contacts, press the retainer for final lock condition. The double lock operation is finished by confirmation that the retainer is kept in the final condition by the 2 projections.

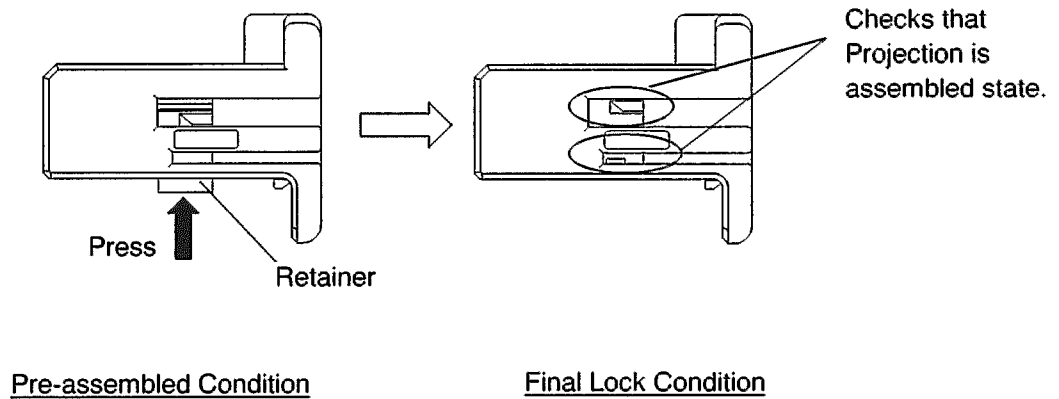

Fig.10

- (2) The double lock operation can not be completed if there are any half inserted contacts. When the retainer can not be pressed to the final condition, do not press by force, find the half inserted contact, and insert it to proper position. See para.6.1.

6.3 How to Unlock Retainer from Final Lock Condition

When the contact requires insertion or extraction, the retainer must be in the pre-assembled condition. The insertion or extraction can not be done in final lock condition.

- (1) Insert the jig, 1mm blade screwdriver, into the window of the retainer pointed by the tear drop mark. See Fig.11(next page).
- (2) Draw out the retainer, about 1mm, to pre-assembled condition. Confirm that all of the projection is unlocked. See Fig.11(next page).

NOTE Do not extract the retainer more than appropriate length. Otherwise the retainer may be damaged

PRELIMINARY

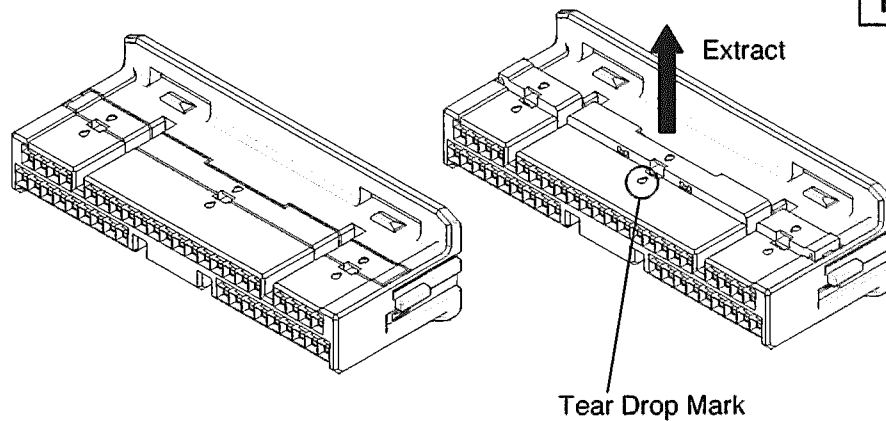

Fig.11

6.4 How to Extract Contact

- (1) Confirm the retainer is in pre-assembled condition. When the retainer is in final lock condition, it must be changed to pre-assembled condition. See para.6.3. The female contact can not be extracted in final assembled condition.
- (2) In the case of 0.50 female contact, insert the special extractive jig into the proper hole to the end, remove the loaded contact from housing while pull the crimped wire. See Fig.12.

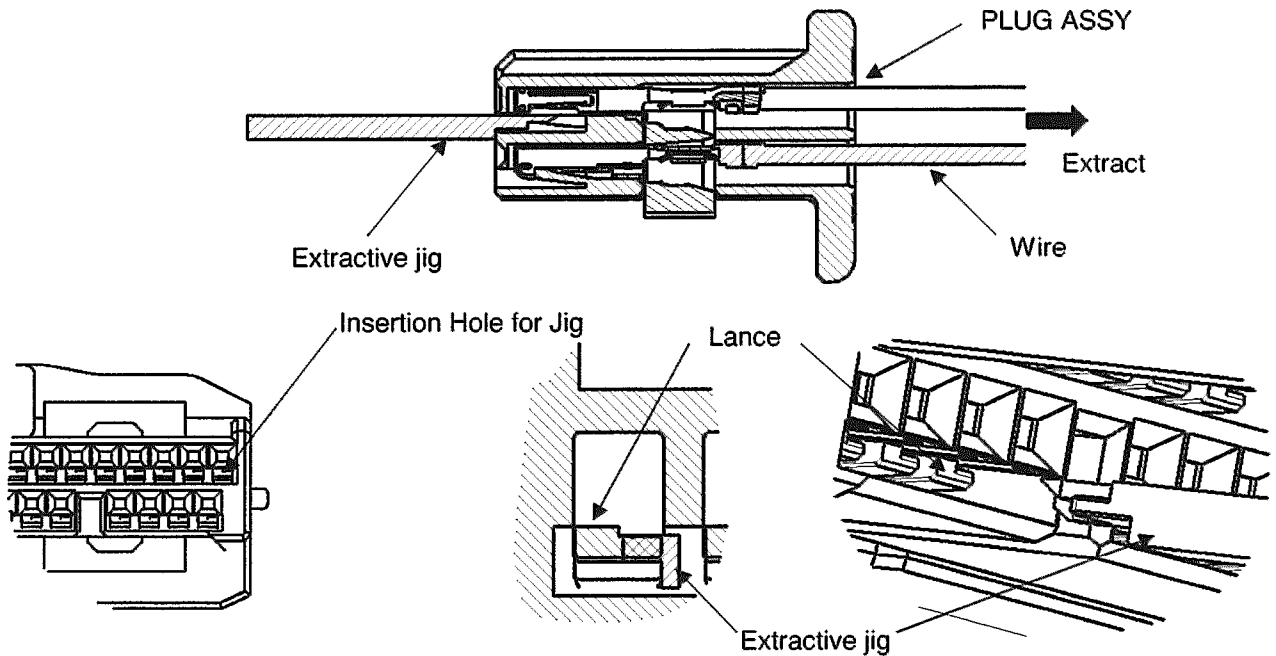

Fig.12

NOTE *If only insert the jig, the 0.50 housing lance will be released. Take care not to apply unnecessary force, otherwise the deformation of the jig occurs or it is cause for falling of retention force by the deformation of the contact lance. And do not repeat extract more than 10 times, otherwise the retention force has fallen.*

NOTE *Do not extract the retainer by this extractive jig (for 0.50 contact).*

PRELIMINARY

(3) In the case of 0.50 male contact, insert the special extractive jig into the proper hole to the end, remove the loaded contact from housing while pull the crimped wire. See Fig.12.

NOTE *Take care not to insert the screwdriver or the extractive jig into the female contact. If those should be inserted, the female contact must be renewed. Re-using is never allowed.*

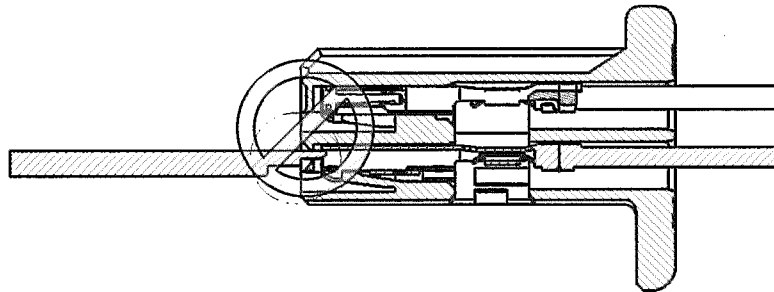

Fig13

PRELIMINARY

6.5 Harness Control

6.5.1 Handling

Take care not to apply unnecessary force or shock to the connector or the wire.

6.5.2 Taping up Wires

The wires must not be taped up more than 30mm from the end of the housing to avoid applying unnecessary force to the wires.

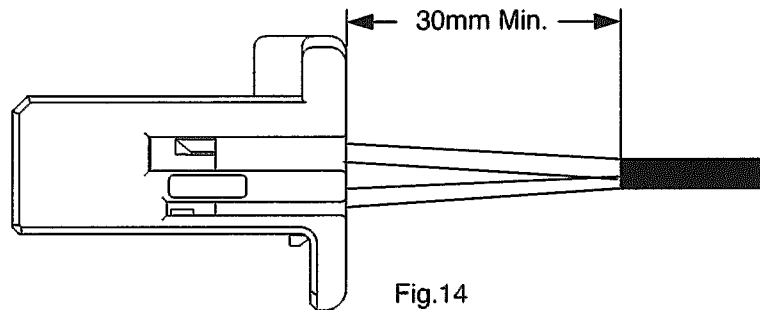

Fig.14

6.5.3 Electric Circuit Check

- (1) For making a check on electric circuit, the applicable mating half or equivalent product should be used.
- (2) Never insert the probe pin for the inspection into the female contact. The pin must be probed from the wire side.

NOTE If the probe pin should be inserted, the female contact must be renewed.

- (3) Contact Tyco if the check jig is required.

6.5.4 Storage

Avoid storing the connector in a moist or dusty place.

Stock the connector away from direct sunlight.

6.5.5 Shipping and Carrying

The connector should be used with the proper packaging to prevent the ingress of dust, moisture, etc.

7. Mating and Extraction of Connector

7.1 Mating of Connector

- (1) Check to make sure that the contact is inserted into the housing in proper condition, the wire is taped up from proper position, and the retainer is in final lock condition. If the retainer is in pre-assembled condition, it must be changed to be in final lock condition. See para.5.
- (2) And then check the contact and the housing into the male housing for defects, deformation, discoloration, damage, rust, crack, deficit, etc.

NOTE The connector must be renewed if any defects are found.

PRELIMINARY

(3) Insert the proper female housing into the male housing straight with same direction as shown in Fig.17. The operation is finished when you hear the click sound and can not insert further. When you can not insert the housing, do not insert by force, and check the items in (1),(2).

NOTE *At the insertion operation, take care not to apply force except in the insertion direction.*

NOTE *At the insertion operation, take care not to hit the female housing to upper & bottom lock of the male housing(as for the worst, the male housing drops out of the panel).*

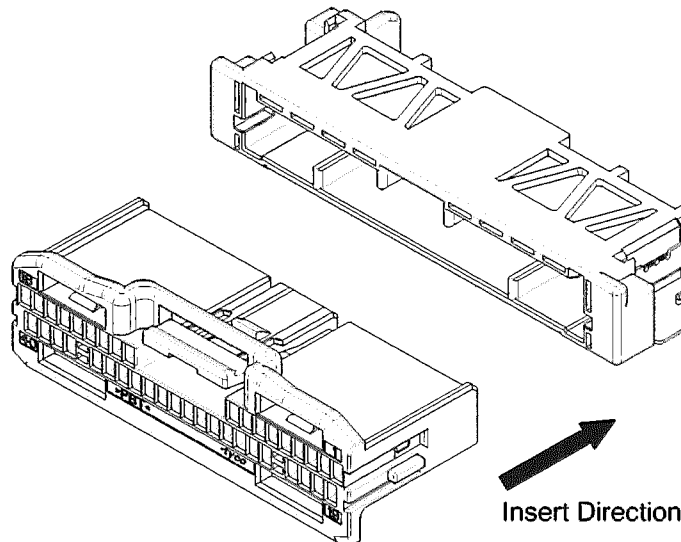

Fig.15

(4) By pulling the female connector lightly, check to make sure that the connector can not be withdrawn.

7.2 Extraction of Connector

Grip the female housing, and then draw straight out while pressing down the locking lever.

When the housing can not be drawn out, do not pull it by force but check to make sure if the locking mechanism is released.

NOTE *At the extraction operation, take care not to apply force except in the extraction direction.*

NOTE *Do not pull the wire only.*

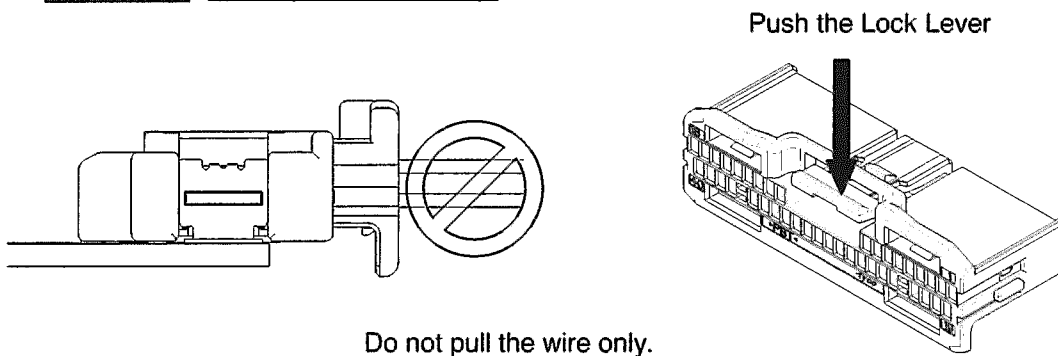

Do not pull the wire only.

Fig.18

7.3 General Attention Matters

- (1) Do not mate and extract the connector unnecessarily.
- (2) Do not insert any objects except the proper connector.
- (3) At mating/extraction operation, or after mating operation, take care not to apply unnecessary force or shock to the wire and the connector.